



VALVES AND FITTINGS

CATÁLOGO CATALOGUE



2020



INDUSTRIAL

Introducción	01
Introduction	

Novedades	09
News	

Válvulas de acero inoxidable	14
Stainless steel valves	

Válvulas de latón	58
Brass valves	

Válvulas de fundición	67
Casting valves	

Válvulas de mariposa	92
Butterfly valves	

Válvulas industriales automatismos	117
Industrial valves automatisms	

Manguito elásticos	158
Rubber expansion join	

Accesorio inoxidable bridas	163
Stainless steel fittings flanges	

Accesorio inoxidable roscado	181
Stainless steel fitting threaded	

Accesorio inoxidable para soldar	195
Welding fitting schedule	

Accesorio inoxidable MT Press	205
MT Press stainless steel fittings	

Manómetros	226
Pressure gauges	

Condiciones de venta	230
Sales conditions	

Índice de referencias	232
References index	

Anexo	234
Annex	

YEARS
25

1994_2019

VALVES AND FITTINGS

Desde 1994, MT diseña, produce y comercializa una amplia gama de productos para el segmento hidrosanitario e industrial entre los que destacan los accesorios y las válvulas de latón, accesorios de acero inoxidable, bridas y válvulas industriales, entre otros.

Since 1994, MT has been designing, producing and marketing a wide range of products for the hydrosanitary and industrial segment, including brass valves and fittings, stainless steel fittings, flanges and industrial valves, among others.

La compañía basa su estrategia en la satisfacción del cliente con una excelente relación calidad precio en más de 4.000 referencias especialmente producidas para el profesional distribuidor.

The aim of the company is the customer satisfaction, trying to give the best quality – price combination in more than 4,000 references, specially made for the professional distributor.

Con una alta cuota de mercado, MT se posiciona como una de las empresas más completas en soluciones integrales para la conducción de fluidos, segmento clave para el sector industrial, tratamientos de agua y riego, usos hidrosanitarios, automatización, instrumentación, etc.

With a nice market presence, MT is positioned as one of the most complete companies in integral solutions for the conduction of fluids, key segment for the industrial sector, water and irrigation treatments, hydrosanitary uses, automation, instrumentation, etc.

Actualmente, MT cuenta con una red de distribuidores propios en más de 12 países, una filial en México (MT América), y clientes en 40 países de 4 continentes.

Nowadays, MT has a network of its own distributors in more than 12 countries, a subsidiary in Mexico (MT America) and clients in 40 countries on 4 continents.

MT es una multinacional española que fabrica y comercializa productos y accesorios para la canalización y conducción de fluidos en más de 40 países.

MT is an spanish company that manufactures and distributes products and accessories for the canalization and conduction of fluids in more than 40 countries.



PRODUCTOS

PRODUCTS

Todas las referencias de MT las encontrarás bajo dos grandes divisiones: Hidro e Industrial, con las que la compañía quiere dar una respuesta específica según el ámbito para el que se han diseñado.

MT portfolio of products are braced in two major divisions: Hydro and Industrial, and with those two divisions we try to give the specific solution on each situation.



La división Hidro MT agrupa todos los productos específicamente diseñados para la canalización y conducción de fluidos para los sectores de construcción, fontanería, riego y jardín.

Se trata de una amplia gama de productos en la que encontraremos accesorios de hierro maleable galvanizado, válvulas de latón y accesorios de latón, reductoras de presión, válvulas de PVC, válvulas y descargas para WC, manómetros, y una selección de los productos más importantes de MAC3, fabricante mundial de productos electrónicos para sistemas hidráulicos.

The Hidro MT division contains all the products, specifically designed for the canalization and conduction of fluids for the construction, plumbing, irrigation and gardening sectors.

It is a wide range of products in which we find malleable galvanized iron fittings, brass valves and brass fittings, pressure reducers, PVC valves, WC valves and discharges, manometers and a selection of the most important products of MAC3, an Italian manufacturer of electronic products for hydraulic systems.



MT® INDUSTRIAL

La división Industrial ofrece piezas de gran calidad de acero inoxidable específicamente pensados para el ámbito industrial. Toda la gama está fabricada bajo estrictos parámetros de calidad cumpliendo con las más altas certificaciones en conducción de fluidos.

Se trata de una amplia gama de productos inox con referencias de bridas y valonas de acero inoxidable, accesorio roscado de acero inoxidable, accesorios para la soldadura de tubo inoxidable, MT Press para prensar, válvulas inoxidables, válvulas de fundición y automatismos.

The Industrial division offers high quality stainless steel parts specifically designed for the industrial sector. The entire range is manufactured under strict quality parameters that comply with the highest certifications in conducting fluids.

It is a wide range of stainless steel products including stainless steel flanges, threaded fittings, welding accessories, MT press fitting, valves, casting valves, ductile valves and automatism.



CERTIFICADOS CERTIFICATIONS

EMPRESA COMPANY

Desde su creación, MT ha apostado por fijar objetivos de calidad e innovación sobre los que construir productos eficientes, seguros, duraderos y altamente rentables. La compañía permanece totalmente alineada con la legislación Europea, cada vez más estricta en sus políticas medioambientales, seguridad e higiene, y apuesta por el desarrollo continuo de nuevas líneas de producción. MT es hoy referente en calidad y homologaciones.

Since its inception, MT has focused its efforts on establishing quality and innovation objectives to build efficient, safe, durable and highly profitable products. The company remains fully aligned with European legislation, keeping ourselves strict in its policies on environment, safety and hygiene, and is committed to the continuous development of new production lines. MT is now a benchmark in quality and approvals.

Certificado TÜV para la Gestión de la Calidad

La organización demuestra su capacidad para proporcionar de forma coherente productos o servicios que satisfacen los requisitos del cliente y los reglamentos aplicables según la norma UNE-EN ISO 9001.

TÜV Quality Management Certificate

The organization demonstrates its ability to consistently deliver products or services that meet customer and regulatory requirements applicable to UNE-EN ISO 9001.



PRODUCTOS

PRODUCTS



La Asociación alemana del sector de gas y agua (DVGW) certifica, entre otros, materiales de sellado para el abastecimiento de gas en Alemania.

The German Association of the Gas and Water Industry (DVGW) certifies, among other things, sealing materials for gas supply in Germany.



Certificación para el empleo de materiales de juntas de sellado con agua potable de acuerdo con la norma británica BS 6920.

Certification for the use of sealing gasket materials with drinking water in accordance with British Standard BS 6920.



Autorización oficial expedida por la Dirección General Sanitaria francesa desde 1998. Se aplica a los materiales constitutivos de los equipos que están en contacto con el agua destinada al consumo humano así como a los equipos en sí.

Official authorization issued by the General Directorate of Health since 1998 (ACS certification). It is applied to equipment constituting materials that are in contact with water intended for human consumption, as well as to the equipment itself.



Autorización oficial expedida por Le Centre Scientifique et Technique du Bâtiment (CSTB).

Official authorization issued by the Center Scientifique et Technique du Bâtiment (CSTB).



Certificación de sistemas de tubería multicapa para instalaciones de agua potable (caliente y fría) en edificación de acuerdo con la normativa EN ISO 21003.

Certification of multilayer piping systems for hot and cold drinking water inside buildings in accordance with EN ISO 21003.



Certificado de sistema tubería PE-X para instalaciones de agua caliente y fría en instalaciones de agua sanitaria y calefacción de acuerdo a normativa UNE-EN ISO 15875 y BRL 5606.

Certification of PE-X piping systems for hot and cold drinking water and heating installations in accordance with UNE-EN ISO 15875 and BRL 5606.



Certificación conforme el producto cumple con la normativa UNE-EN 13828 (diseño) y la NKB-13 (migración metales pesados).

Certification according the product complies with UNE-EN 13828 (design) and NKB-13 (heavy metal migration).



Certificación oficial expedida por el Instituto Nacional de Sanidad Pública de Polonia. Se aplica a los materiales constitutivos de los equipos que están en contacto con el agua destinada al consumo humano.

Official certificate issued by the National Institute of Public Hygiene of Poland. It is applied to equipment constituting materials that are in contact with water intended for human consumption.



Certificación de conformidad para los productos que cumplen con todos los reglamentos técnicos de la Unión Aduanera Euroasiática.

Product compliance Certificate according to the technical regulations of the Eurasian Custom Union.

VALOR DIFERENCIAL

DIFERENCIAL VALUE

MT se ha posicionado en el mercado como una de las empresas más ágiles en capacidad de respuesta, relación calidad-precio y catálogo de referencias.

La compañía ha definido una estrategia comercial basada en precios competitivos y una máxima preocupación: no sobre-estocar al cliente. Esto nos permite ajustar la producción a las necesidades reales del mercado y sus profesionales y ofrecer:

MT has positioned itself in the market as one of the most agile companies in terms of responsiveness, value for money and reference catalog.

The company has defined its commercial strategy based on competitive prices and a maximum concern: not over-store the customer. This allows us to adjust production to the real needs of the market and its professionals and offer:



MT ha consolidado una red de distribución internacional, entendiendo las especificidades que marca cada mercado y adaptando certificaciones y requerimientos de cada país.

El modelo logístico pone el foco en la anticipación y la capacidad de respuesta en un amplio catálogo de productos. Esto es posible, entre otros, gracias al código EAN incorporado en cada uno de sus productos, imprescindible para un óptimo control de los stocks y la venta de productos por línea de caja.

MT has consolidated an international distribution network, understanding the specificities that mark each market and adapting the certifications and requirements of each country.

The logistic model puts the focus on anticipation and responsiveness in a wide product catalog. This is possible, among others, thanks to the EAN code incorporated in each of its products, essential for optimum control of stocks and the sale of products on counters.

Condiciones válidas sólo en España
Valid conditions only in Spain



Nuevo servicio urgente 24h.
New urgent service 24h.

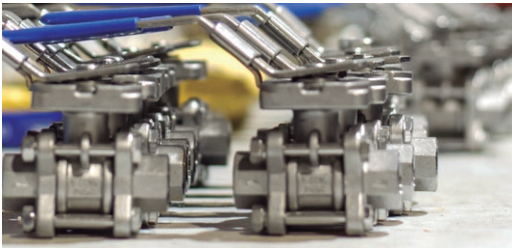

Amplio catálogo de productos
con más de 4.000 referencias
Wide catalog of products with
more than 4.000 references



Producción homologada según
normativas y certificaciones
Production approved according
to regulations and certifica-
tions



Servicio logístico que vela por
el no sobre-estocaje del cliente
Logistic service that monitors
non-storage



Atención al cliente basada en
la inmediatez y la flexibilidad
Customer support based on
immediacy and flexibility

Consultar condiciones de venta página 230
See sales conditions on page 230



Tel. +34 936 804 980
Fax. +34 936 804 981

www.mtspain.net
info@mtspain.net

Pol. Sector Camps d'en Ricart
C/ Comerç, 10, naves 3 a 9
08780 Pallejà, Barcelona - SPAIN

MT®
VALVES AND FITTINGS

NOVEDADES NEWS

Cajas dispensadoras completamente personalizables, blisters y embolsados. Todo para facilitar su correcta identificación y clasificación.

Dispenser boxes completely customizable, blister packs and bagged. All to facilitate its correct identification and classification.

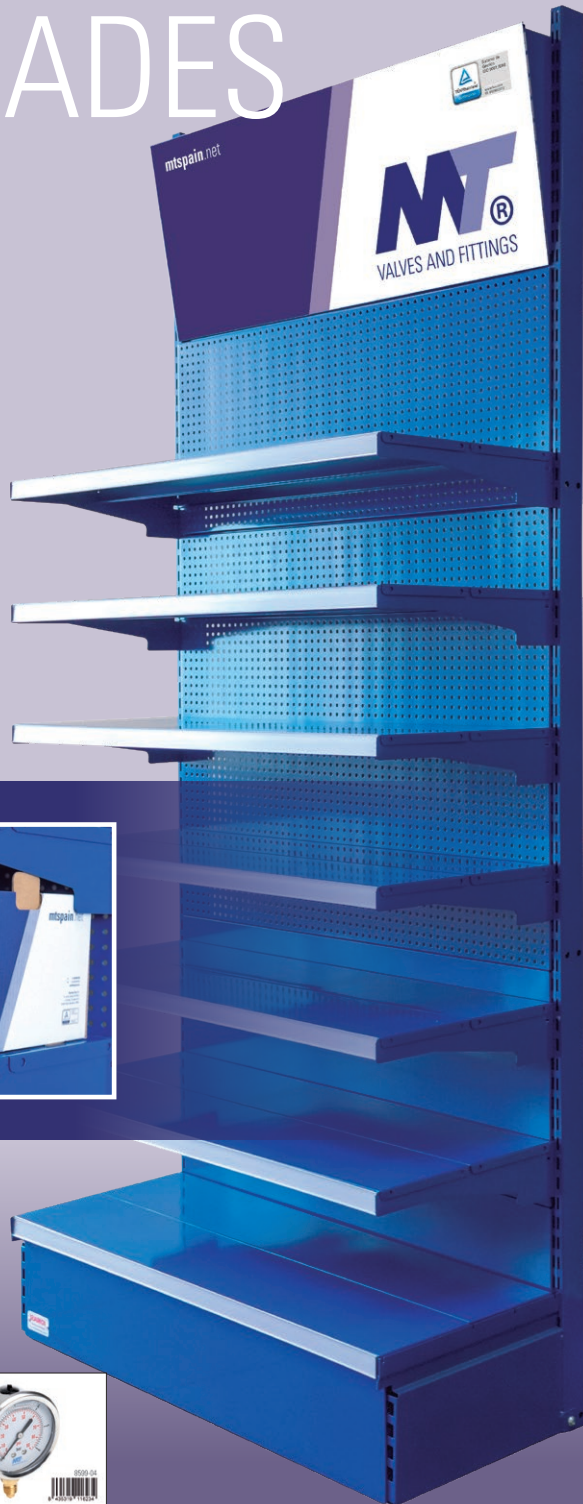



SOLUCIONES DE MARKETING A MEDIDA

CUSTOMIZED MARKETING SOLUTIONS

Dos factores determinan los resultados en el punto de venta: visibilidad y notoriedad. Ser capaces de llamar la atención del consumidor y transmitir el concepto y las principales ventajas técnicas del producto es otro de nuestros máximos objetivos.

MT pone a disposición de sus clientes un completo abanico de soluciones orientadas a reforzar sus acciones comerciales en el punto de venta con un fin: reforzar la identidad corporativa de los productos ofertados y facilitar al máximo la venta.

- Acciones de marketing promocional
- Comunicación retail
- Productos dotados de herramientas comerciales especialmente creadas: expositor, bolsas, etiquetas, categorías, muestras, etc.

There are two factors that determine the results in point of sale: visibility and notoriety. Be able to attract attention of customers and transmit the concept and the main technical advantages of our products is other of our main goals.

MT makes available to the customers a complete variety of solutions oriented to reinforce his point of sale commercial actions with a goal: reinforce the corporate identity of the quoted products and facilitate at maximum the sale..

- Promotional marketing actions
- Retail communication
- Products equipped with commercial tools specially designed for them: exhibitor, bags, labels, categories, samples, etc.

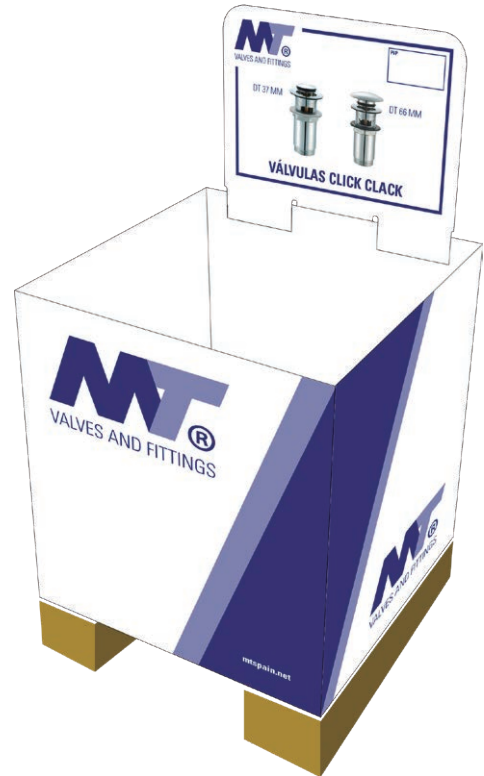

Box pallet personalizable para punto de venta.
Customizable box pallet for point of sale.

NUESTRAS HERRAMIENTAS COMERCIALES

- Implantaciones por familias de productos.
- Cajas dispensadoras etiquetadas para estanterías modulares.
- Box pallet para punto de venta.

OUR COMMERCIAL TOOLS

- Establishments by product families.
- Dispenser boxes labeled for modular shelves.
- Box pallet for point of sale.

pag.



92

NUEVA GAMA DE VÁLVULAS DE MARIPOSA

NEW RANGE OF BUTTERFLY VALVES



5114

VÁLVULA DE MARIPOSA TIPO WAFER BRIDA UNIVERSAL ASIENTO BLANDO
BUTTERFLY VALVE WAFER TYPE UNIVERSAL FLANGED SOFT SEAT

PAG. 94



Cuerpo Body
GGG40

Eje Stem
Acero Inoxidable Stainless steel

Disco Disc
Acero Inoxidable Stainless steel

Asiento Seat
Asiento blando EPDM Soft Seat EPDM

Maneta Handle
Aluminio Aluminium

Brida Flanges
PN-6/10/16 ANSI 125-150

5140

VÁLVULA MARIPOSA TIPO WAFER EPDM DISCO POLIAMIDA 11
BUTTERFLY VALVE WAFER TYPE EPDM POLYAMIDE 11 DISC

PAG. 100



Cuerpo Body
GGG40

Eje Stem
Acero Inoxidable Stainless steel

Disco Disc
Fundición poliamida 11 Ductil iron polyamide 11

Asiento Seat
Asiento blando EPDM Soft Seat EPDM

Maneta Handle
Aluminio Aluminium

Brida Flanges
PN-6/10/16 ANSI 125-150

51151

VÁLVULA DE MARIPOSA TIPO WAFER DISCO INOXIDABLE BRIDA UNIVERSAL
BUTTERFLY VALVE WAFER TYPE STAINLESS STEEL DISC UNIVERSAL FLANGED

PAG. 104

ECO

NUEVO
NEW



Cuerpo Body
GG25 < DN200, GGG40 > DN200

Eje Stem
Acero Inoxidable Stainless steel

Disco Disc
Acero Inoxidable Stainless steel

Asiento Seat
Asiento duro EPDM Hard Seat EPDM

Maneta Handle
Acero Steel

Brida Flanges
PN-6/10/16 ANSI 125-150

5115

VÁLVULA DE MARIPOSA TIPO WAFER BRIDA UNIVERSAL
BUTTERFLY VALVE WAFER TYPE UNIVERSAL FLANGED

PAG. 108

ECO

NUEVO
NEW



Cuerpo Body
GG25 < DN200, GGG40 > DN200

Eje Stem
Acero al carbono Carbon steel

Disco Disc
Cromado Chrome

Asiento Seat
Asiento duro EPDM Hard Seat EPDM

Maneta Handle
Acero Steel

Brida Flanges
PN-6/10/16 ANSI 125-150

APLICACIONES

Instalaciones de agua fría y caliente, vapor baja presión, instalaciones químicas, disolventes, fluidos de todo tipo y aire.

Industrias químicas, industrias petroquímicas, industrias alimentarias para proceso externas y auxiliares.

Conducción de fluidos, calderas, intercambiadores de calor.



APPLICATIONS

Installations of cold and hot water, low pressure steam, chemical installations, solvents, fluids and air.
Chemical industries, petrochemical industries, food industries for external and auxiliary process.
Fluid conduction, boilers, heat exchangers.

VÁLVULAS INOX.

STAINLESS STEEL VALVES



VÁLVULAS DE ACERO INOXIDABLE

STAINLESS STEEL VALVES

PRODUCTO

Válvula de acero inoxidable

CONEXIONESRoscada, BSP o NPT
Bridas DIN - ANSI - EN 1092
Soldadas BW y SW**CALIDAD**AISI 316/316L
WCB - Acero al carbono
Paso total o reducido**PRODUCT**

Stainless steel valve

UNIONSThreaded, BSP or NPT
Flanges DIN - ANSI - EN 1092
Weld BW - SW**QUALITY**AISI 316/316L
WCB - Carbon steel
Full bore or reduced bore**LEYENDA DE ICONOS****ICON KEY**Posibles codificaciones
aplicadas en esta sección.Possible encodings applied
in this section.**INOX**Inoxidable
Stainless steel**PROPIEDADES DE PRODUCTO**
PRODUCT PROPERTIES

0909

VÁLVULA DE ESFERA UNA PIEZA ROSCAR PASO REDUCIDO BSP
BALL VALVE ONE PIECE THREADED END REDUCED BORE BSP

INOX

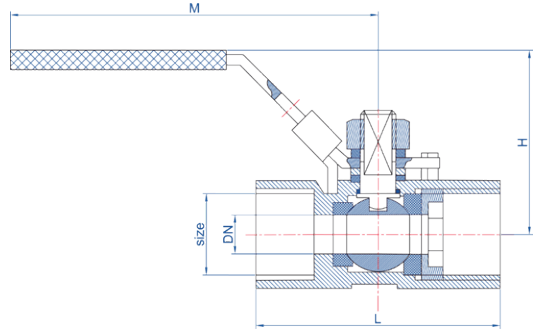

- Cuerpo y bola acero inoxidable CF8M (AISI-316)
Body and ball made of stainless steel CF8M (AISI-316)
- Asientos bola en PTFE
PTFE ball seats
- Roscas H-H BSP s/ norma ISO 228/1 (DIN 259)
F-F BSP Threads ISO 228/1 (DIN 259)

- Presión máxima de trabajo: 63 Bar (1000 psi)
Max. working pressure: 63 Bar (1000 psi)
- Temperatura de trabajo: -20°C / 180°C
Working temperature: -20°C / 180°C
- Paso reducido
Reduced bore

DIMENSIONES / DIMENSIONS

CÓDIGO	MEDIDA	DN	L	H	M			€
CODE	SIZE	DN	L	H	M			€
0909-008	1/4"	5	32	31	65	100	50	8,64
0909-010	3/8"	7	44	34	88	60	30	9,11
0909-015	1/2"	9,2	56,5	40	95	50	25	10,48
0909-020	3/4"	12,8	59	43	100	36	18	15,79
0909-025	1"	15	71	49,5	110	20	10	20,11

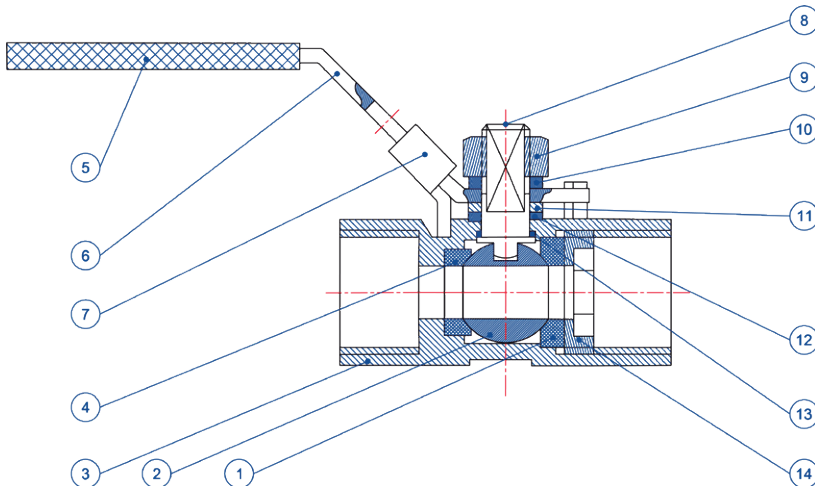

MATERIALES / MATERIALS

Nº	NOMBRE	MATERIALES	CALIDAD
Nº	NAME	MATERIALS	QUALITY
1	Junta Joint ring	PTFE	PTFE
2	Bola Ball	Acero inoxidable Stainless steel	316 (CF8M)
3	Cuerpo Body	Acero inoxidable Stainless steel	AISI 316 (CF8M)
4	Asientos Seats	RPTFE	RPTFE
5	Cubre palanca Handle cover	Plástico Plastic	PVC
6	Maneta Handle	Acero inoxidable Stainless steel	304
7	Mecanismo de cierre Lock device	Acero inoxidable Stainless steel	304
8	Eje Stem	Acero inoxidable Stainless steel	304
9	Tuerca del eje Stem nut	Acero inoxidable Stainless steel	304
10	Arandela del eje Stem washer	Acero inoxidable Stainless steel	304
11	Tuerca casquillo Gland nut	Acero inoxidable Stainless steel	304
12	Asiento del eje Stem packing	PTFE	PTFE
13	Arandela de empuje Thrust washer	PTFE	PTFE
14	Accesorio de inserción Insert	Acero inoxidable Stainless steel	316 (CF8M)

GRÁFICO PRESIÓN-TEMPERATURA / PRESSURE TEMPERATURE CHART

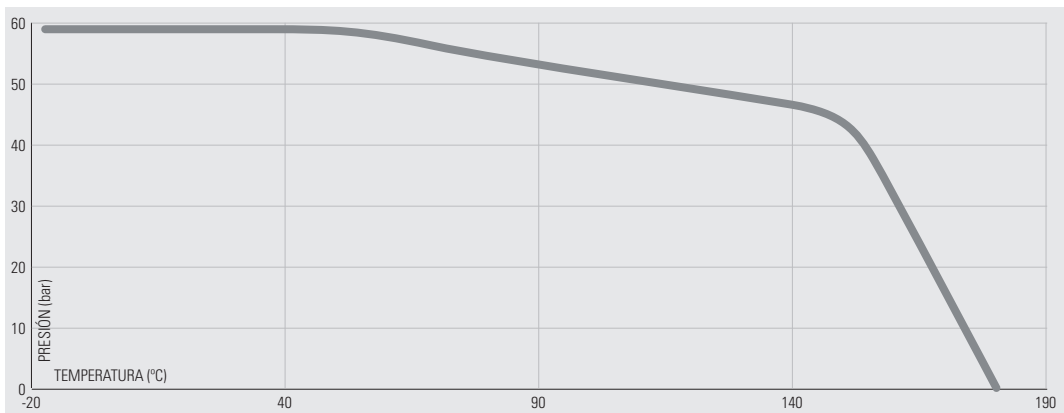

0917

VÁLVULA ESFERA DOS PIEZAS ROSCAR PLATAFORMA DE MONTAJE
BALL VALVE TWO PIECES WITH MOUNTING PAD FULL BORE THREADED END

INOX

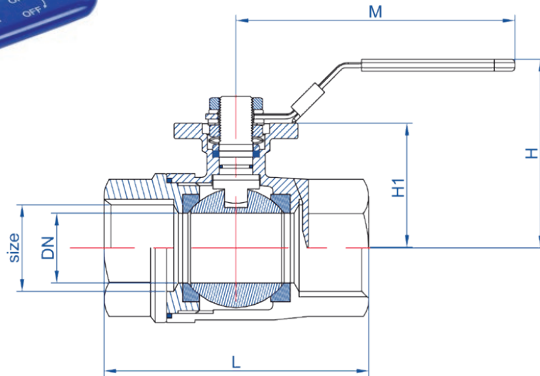
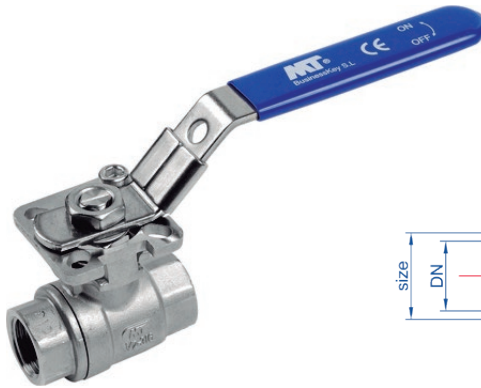

- Cuerpo y bola acero inoxidable CF8M (AISI-316)
Body and ball made of stainless steel CF8M (AISI-316)
- Asientos bola en PTFE
PTFE ball seats
- Roscas CNC H-H BSP s/ norma ISO 228 (DIN 259)
F-F CNC BSP Threads ISO 228 (DIN 259)

- Plataforma montaje directo ISO 5211
Direct mounting Pad ISO 5211.
- Presión máxima de trabajo: 63 Bar (1000 psi)
Max. Working pressure: 63 Bar (1000 psi)
- Temperatura de trabajo: -20°C / 180°C
Working temperature: -20°C / 180°C
- Paso total
Full bore

DIMENSIONES / DIMENSIONS

CÓDIGO	MEDIDA	DN	L	H	H1	M			€
CODE	SIZE	DN	L	H	H1	M			€
0917-008	1/4"	11,6	50	51,5	36,5	91	80	40	19,62
0917-010	3/8"	12,5	50	51,5	36,5	91	80	40	19,62
0917-015	1/2"	15	58	53	37,8	100	60	30	20,82
0917-020	3/4"	20	65	58	42,5	113	36	18	31,51
0917-025	1"	25	80	60	45	113	20	10	40,35
0917-032	1 1/4"	32	92	66,5	51,5	143	14	7	57,80
0917-040	1 1/2"	38	105	74,5	59,5	143	8	4	74,85
0917-050	2"	50	125	83,5	68,5	165	5	1	116,18

DIMENSIONES ISO 5211 / FLANGE ISO 5211 DIMENSIONS

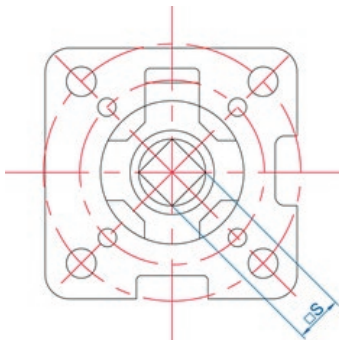

MEDIDA	DN	ISO 5211	S	TORQUE
SIZE	DN	ISO 5211	S	Nm
1/4"	8	F03-F04	9x9	3-4
3/8"	10	F03-F04	9x9	3-4
1/2"	15	F03-F04	9x9	4-5
3/4"	20	F03-F04	9x9	5-7
1"	25	F04-F05	11x11	12-14
1 1/4"	32	F04-F05	11x11	12-14
1 1/2"	40	F05-F07	14x14	20-25
2"	50	F05-F07	14x14	25-30

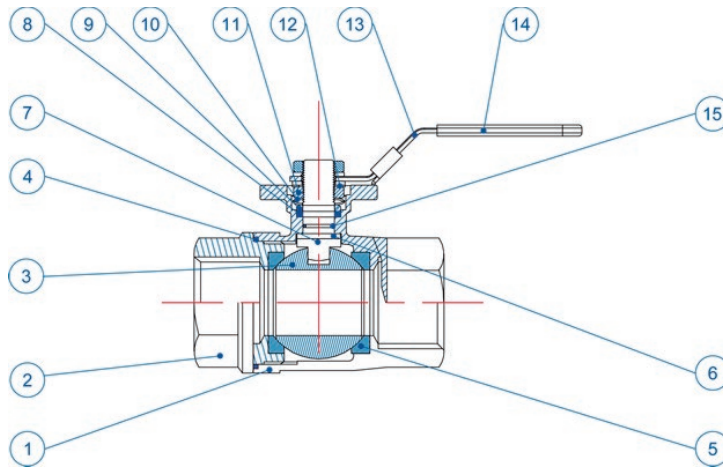

MATERIALES / MATERIALS

Nº	NOMBRE	MATERIALES	CALIDAD
Nº	NAME	MATERIALS	QUALITY
1	Cuerpo Body	Acero inoxidable Stainless steel	AISI 316
2	Tapa Cap	Acero inoxidable Stainless steel	AISI 316
3	Bola Ball	Acero inoxidable Stainless steel	AISI 316
4	Junta cuerpo Body seal	PTFE	PTFE
5	Asiento Seat	PTFE	PTFE
6	Arandela apriete Thrust washer	PTFE	PTFE
7	Eje Stem	Acero inoxidable Stainless steel	AISI 316
8	Cierre eje Stem packing	PTFE	PTFE
9	Anillo prensaestopa Gland ring	Acero inoxidable Stainless steel	AISI 304
10	Arandela resorte Spring washer	Acero inoxidable Stainless steel	AISI 304
11	Tuerca eje Stem nut	Acero inoxidable Stainless steel	AISI 304
12	Arandela bloqueo tuerca Against pine pad	Acero inoxidable Stainless steel	AISI 304
13	Palanca Handle	Acero inoxidable Stainless steel	AISI 304
14	Cubierta palanca Plastic cover	Plástico Plastic	PVC
15	Junta tórica O-ring	FKM	FKM

GRÁFICO PRESIÓN-TEMPERATURA / PRESSURE TEMPERATURE CHART

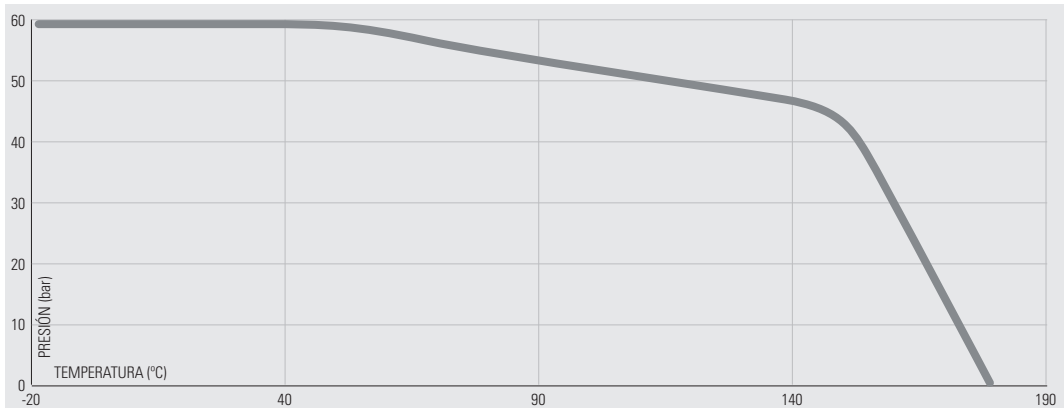

0910 09102

VÁLVULA DE DOS PIEZAS ROSCAR H-H
F-F BALL VALVE TWO PIECES THREADED END FULL BORE

INOX

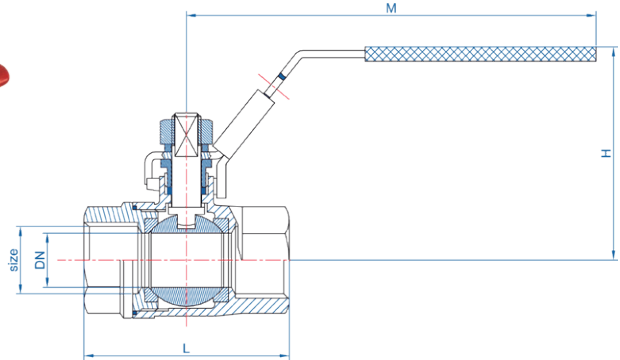

- Cuerpo fabricado en acero inoxidable CF8M (AISI-316)
Body made of stainless steel CF8M (AISI-316)
- Bola fabricada en acero inoxidable CF8M (AISI-316)
CF8M (AISI-316) stainless steel ball
- Asientos bola en PTFE
PTFE ball seats
- Roscas H-H BSP s/ norma ISO 7/1
F-F BSP Threads ISO 7/1

- Maneta color azul (Ref. 0910) y maneta color rojo (Ref.09102)
Blue handle cover (Ref. 0910) and red handle cover (Ref.09102)
- Paso total
Full bore
- Presión máxima de trabajo: 63 Bar (1000 psi)
Max. working pressure: 63 Bar (1000 psi)
- Temperatura de trabajo: -20°C / 180°C
Working temperature: -20°C / 180°C

0910

CÓDIGO	MEDIDA	DN	L	H	M			€
CODE	SIZE	DN	L	H	M			€
0910-008	1/4"	11,6	48	48	91	48	24	9,97
0910-010	3/8"	12,5	48	48	91	48	24	9,97
0910-015	1/2"	15	56	52	100	32	16	11,50
0910-020	3/4"	20	65	58	113	24	12	16,22
0910-025	1"	25	77	63	113	16	8	22,85
0910-032	1 1/4"	32	87	75	143	10	1	36,69
0910-040	1 1/2"	38	98	75	143	10	1	50,98
0910-050	2"	50	119	90	165	6	1	80,40
0910-065	2 1/2"	65	145	100	230	4	1	165,16
0910-080	3"	76	166	124	230	3	1	236,02

09102

CÓDIGO	MEDIDA	DN	L	H	M			€
CODE	SIZE	DN	L	H	M			€
09102-008	1/4"	11,6	48	48	91	48	24	9,97
09102-010	3/8"	12,5	48	48	91	48	24	9,97
09102-015	1/2"	15	56	52	100	32	16	11,50
09102-020	3/4"	20	65	58	113	24	12	16,22
09102-025	1"	25	77	63	113	16	8	22,85
09102-032	1 1/4"	32	87	75	143	10	1	36,69
09102-040	1 1/2"	38	98	75	143	10	1	50,98
09102-050	2"	50	119	90	165	6	1	80,40
09102-065	2 1/2"	65	145	100	230	4	1	165,16
09102-080	3"	76	166	124	230	3	1	236,02

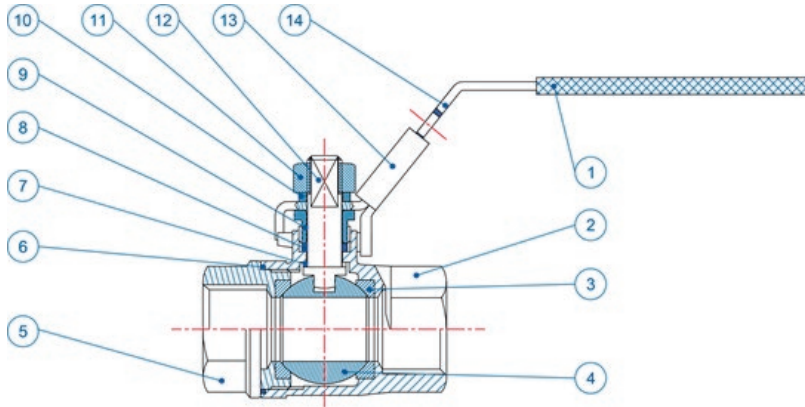

MATERIALES / MATERIALS

Nº	NOMBRE	MATERIALES	CALIDAD
Nº	NAME	MATERIALS	QUALITY
1	Cobertura maneta Handle cover	Plástico Plastic	PVC
2	Cuerpo Body	Acero inoxidable Stainless steel	CF8M
3	Asiento Seat	PTFE	PTFE
4	Bola Ball	Acero inoxidable Stainless steel	AISI 316
5	Tapa Cap	Acero inoxidable Stainless steel	CF8M
6	Junta Gasket	PTFE	PTFE
7	Junta base eje Stem joint	PTFE	PTFE
8	Empaquetadura eje Packing gland	PTFE	PTFE
9	Prensaestopa Packing nut	Acero inoxidable Stainless steel	AISI 304
10	Arandela muelle Spring washer	Acero inoxidable Stainless steel	AISI 304
11	Tuerca Nut	Acero inoxidable Stainless steel	AISI 304
12	Eje Stem	Acero inoxidable Stainless steel	AISI 304
13	Mecanismo bloqueo Lock device	Acero inoxidable Stainless steel	AISI 304
14	Maneta Handle	Acero inoxidable Stainless steel	AISI 304

GRÁFICO PRESIÓN-TEMPERATURA / PRESSURE TEMPERATURE CHART

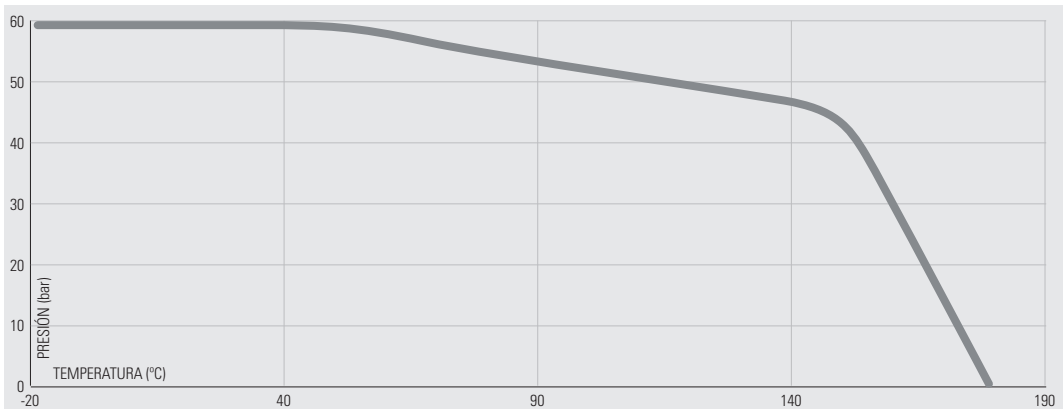

09103

09104

VÁLVULA DE DOS PIEZAS ROSCAR M-H
M-F BALL VALVE TWO PIECES THREADED END FULL BORE

INOX

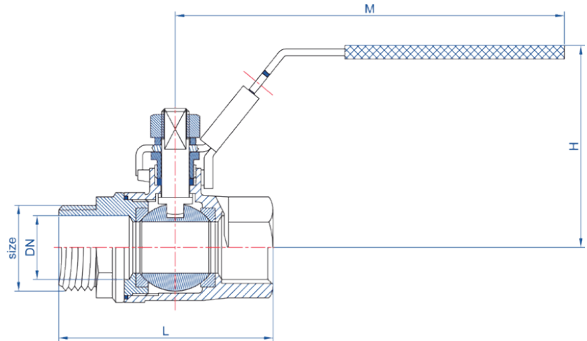

- Cuerpo fabricado en acero inoxidable CF8M (AISI-316)
Body made of stainless steel CF8M (AISI-316)
- Bola fabricada en acero inoxidable CF8M (AISI-316)
CF8M (AISI-316) stainless steel ball
- Asientos bola en PTFE
PTFE ball seats
- Roscas M-H BSP s/ norma ISO 7/1
M-F BSP threads ISO 7/1

- Maneta color azul (Ref. 09103) y maneta color rojo (Ref.09104)
Blue handle cover (Ref. 09103) and red handle cover (Ref.09104)
- Paso total
Full bore
- Presión máxima de trabajo: 1000 psi wog (PN-63)
Max. working pressure: 1000 psi wog (PN-63)
- Temperatura de trabajo: -20°C / 180°C
Working temperature: -20°C / 180°C

09103

CÓDIGO	MEDIDA	DN	L	H	M			€
CODE	SIZE	DN	L	H	M			€
09103-008	1/4"	11,6	48	48	91	48	24	15,83
09103-010	3/8"	12,5	48	48	91	48	24	15,83
09103-015	1/2"	15	56	52	100	32	16	17,04
09103-020	3/4"	20	65	58	113	24	12	22,80
09103-025	1"	25	77	63	113	16	8	30,62
09103-032	1 1/4"	32	87	75	143	10	1	50,80
09103-040	1 1/2"	38	98	75	143	10	1	67,40
09103-050	2"	50	119	90	165	3	1	105,58
09103-065	2 1/2"	65	145	100	230	4	1	225,52
09103-080	3"	76	166	124	230	3	1	360,02
09103-100	4"	100	235	170	300	2	1	617,14

09104

CÓDIGO	MEDIDA	DN	L	H	M			€
CODE	SIZE	DN	L	H	M			€
09104-008	1/4"	11,6	48	48	91	48	24	15,83
09104-010	3/8"	12,5	48	48	91	48	24	15,83
09104-015	1/2"	15	56	52	100	32	16	17,04
09104-020	3/4"	20	65	58	113	24	12	22,80
09104-025	1"	25	77	63	113	16	8	30,62
09104-032	1 1/4"	32	87	75	143	10	1	50,80
09104-040	1 1/2"	38	98	75	143	10	1	67,40
09104-050	2"	50	119	90	165	3	1	105,58
09104-065	2 1/2"	65	145	100	230	4	1	225,52
09104-080	3"	76	166	124	230	3	1	360,02
09104-100	4"	100	235	170	300	2	1	617,14

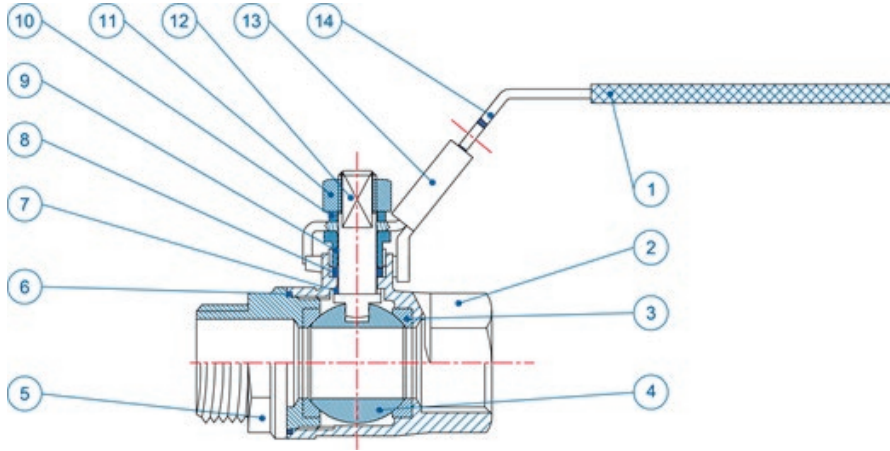

MATERIALES / MATERIALS

Nº	NOMBRE	MATERIALES	CALIDAD
Nº	NAME	MATERIALS	QUALITY
1	Cobertura maneta Handle cover	Plástico Plastic	PVC
2	Cuerpo Body	Acero inoxidable Stainless steel	CF8M
3	Asiento Seat	PTFE	PTFE
4	Bola Ball	Acero inoxidable Stainless steel	AISI 316
5	Tapa Cap	Acero inoxidable Stainless steel	CF8M
6	Junta Gasket	PTFE	PTFE
7	Junta base eje Stem joint	PTFE	PTFE
8	Empaquetadura eje Packing gland	PTFE	PTFE
9	Prensaestopa Packing nut	Acero inoxidable Stainless steel	AISI 304
10	Arandela muelle Spring washer	Acero inoxidable Stainless steel	AISI 304
11	Tuerca Nut	Acero inoxidable Stainless steel	AISI 304
12	Eje Stem	Acero inoxidable Stainless steel	AISI 304
13	Mecanismo bloqueo Lock device	Acero inoxidable Stainless steel	AISI 304
14	Maneta Handle	Acero inoxidable Stainless steel	AISI 304

GRÁFICO PRESIÓN-TEMPERATURA / PRESSURE TEMPERATURE CHART

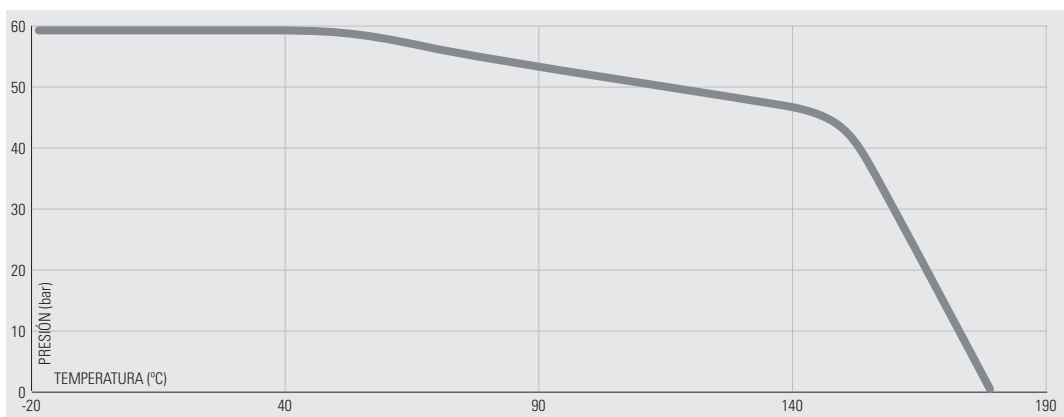

0911

VÁLVULA DE BOLA PASO TOTAL DE TRES PIEZAS
THREE PIECES STAINLESS STEEL BALL VALVE

INOX

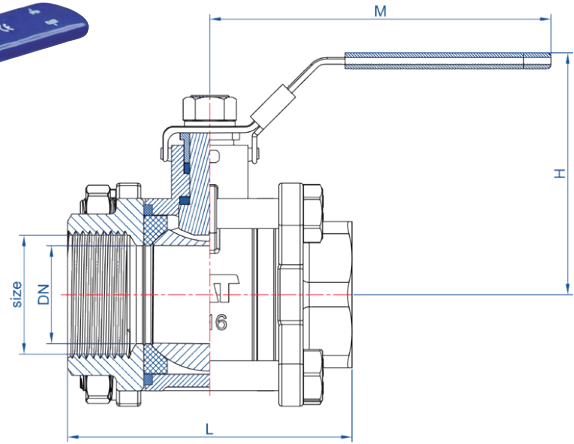
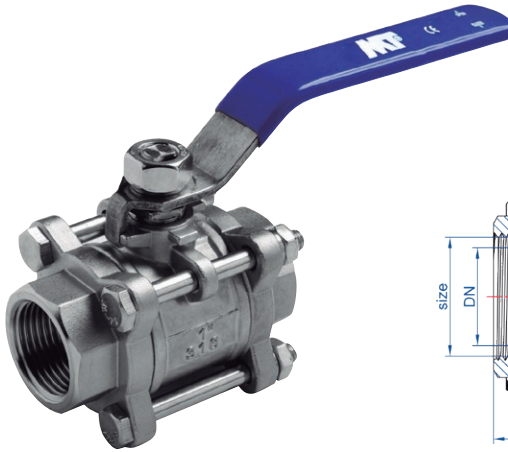

- Cuerpo fabricado en acero inoxidable CF8M (AISI-316)
Body made of stainless steel CF8M (AISI-316)
- Bola fabricada en acero inoxidable CF8M (AISI-316)
CF8M (AISI-316) stainless steel ball
- Asientos bola en PTFE reforzado
Reinforced PTFE ball seats
- Roscas H-H BSP s/ norma ISO 228/1 (DIN 259)
F-F BSP Threads ISO 228/1 (DIN 259)

- Paso total
Full bore
- Presión máxima de trabajo: 63 Bar (1000 psi)
Max. Working pressure: 63 Bar (1000 psi)
- Temperatura de trabajo: -20°C / 180°C
Working temperature: -20°C / 180°C

DIMENSIONES / DIMENSIONS

CÓDIGO CODE	MEDIDA SIZE	DN	L	H	M			€
		DN	L	H	M			€
0911-008	1/4"	11,6	61	49	103	32	16	16,28
0911-010	3/8"	12,5	61	49	103	32	16	17,00
0911-015	1/2"	15	63	57	108	20	10	19,18
0911-020	3/4"	20	72	62	108	16	8	24,90
0911-025	1"	25	82,5	72	129	16	8	36,86
0911-032	1 1/4"	32	97,5	78	129	8	1	51,71
0911-040	1 1/2"	38	108,5	91	160	6	1	78,04
0911-050	2"	50	124	102	160	3	1	121,12
0911-065	2 1/2"	65	162	122	230	3	1	248,91
0911-080	3"	76	175	132	230	2	1	359,03
0911-100	4"	100	216	177	335	2	1	694,15

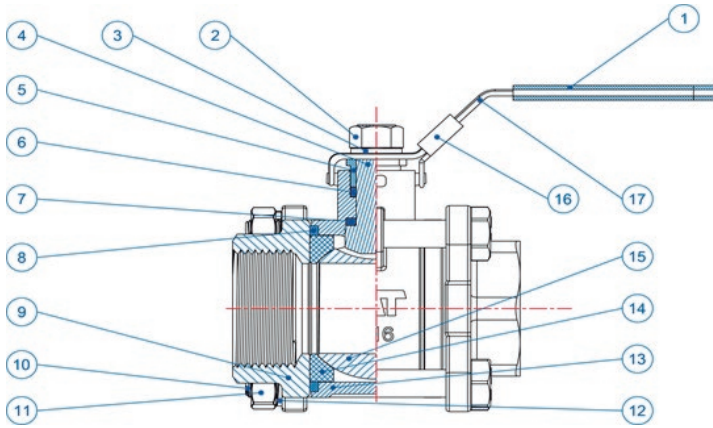

MATERIALES / MATERIALS

Nº	NOMBRE	MATERIALES	CALIDAD
Nº	NAME	MATERIALS	QUALITY
1	Cubrepalanca Handle cover	Plástico Plastic	PVC
2	Tuerca Nut	Acero inoxidable Stainless steel	AISI 304
3	Arandela Washer	Acero inoxidable Stainless steel	AISI 304
4	Eje Stem	Acero inoxidable Stainless steel	AISI 304
5	Casquillo Gland nut	Acero inoxidable Stainless steel	AISI 304
6	Empaquetadura eje Stem packing	PTFE	PTFE
7	Arandela empuje Thrust washer	PTFE	PTFE
8	Junta cuerpo Body gasket	PTFE	PTFE
9	Tapa End cap	Acero inoxidable Stainless steel	AISI 316
10	Tornillo Bolt	Acero inoxidable Stainless steel	AISI 304
11	Tuerca tornillo Bolt nut	Acero inoxidable Stainless steel	AISI 304
12	Arandela tornillo Bolt washer	Acero inoxidable Stainless steel	AISI 304
13	Cuerpo Body	Acero inoxidable Stainless steel	AISI 316
14	Asiento de bola Ball seat	RPTFE	PTFE + Fiberglass
15	Bola Ball	Acero inoxidable Stainless steel	AISI 316
16	Mecanismo bloqueo Lock device	Acero inoxidable Stainless steel	AISI 304
17	Maneta Handle	Acero inoxidable Stainless steel	AISI 304

GRÁFICO PRESIÓN-TEMPERATURA / PRESSURE TEMPERATURE CHART

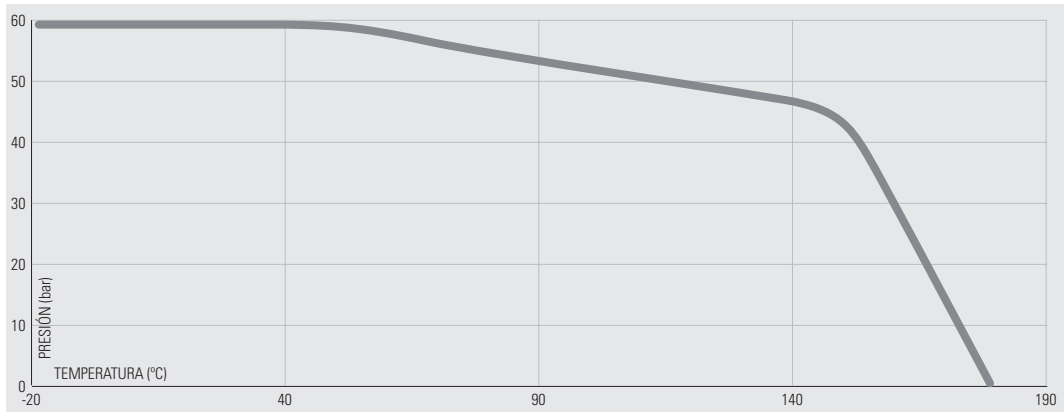

0912

VÁLVULA ESFERA TRES PIEZAS ROSCAR PASO TOTAL PLETINA ISO
THREE PIECES BALL VALVE THREADED END FULL BORE, TOP FLANGE ISO

INOX

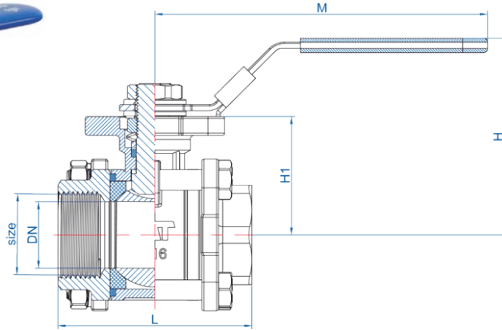

- Cuerpo fabricado en acero inoxidable CF8M (AISI-316)
Body made of stainless steel CF8M (AISI-316)
- Bola fabricada en acero inoxidable CF8M (AISI-316)
CF8M (AISI-316) stainless steel ball
- Asientos bola en PTFE reforzado
Reinforced PTFE ball seats
- Roscas H-H BSP s/ norma ISO 228/1 (DIN 2599)
F-F BSP Threads ISO 228/1 (DIN 2599)

- Plataforma montaje directo ISO 5211
Direct mounting Pad ISO 5211
- Paso total
Full bore
- Presión máxima de trabajo: 63 Bar (1000 psi)
Max. working pressure: 63 Bar (1000 psi)
- Temperatura de trabajo: -20°C / 180°C
Working temperature: -20°C / 180°C

CÓDIGO	MEDIDA	DN	L	H	H1	M			€
CODE	SIZE	DN	L	H	H1	M			€
0912-008	1/4"	11	64	69	38,4	140	24	12	20,87
0912-010	3/8"	12,5	64	69	38,4	140	18	9	20,87
0912-015	1/2"	15	72	72	42	140	16	8	21,83
0912-020	3/4"	20	80	78	48	140	16	8	34,15
0912-025	1"	25	85	90	55	162	8	4	41,54
0912-032	1 1/4"	32	105	95	60	162	6	1	64,82
0912-040	1 1/2"	38	113	105	70	188	4	1	85,74
0912-050	2"	50	132	122	85	188	3	1	121,88
0912-065	2 1/2"	65	170	155	109	233	3	1	302,33
0912-080	3"	76	186	164	118	233	2	1	425,04
0912-100	4"	100	220	185	129	300	1	1	713,45

DIMENSIONES ISO 5211 / FLANGE ISO 5211 DIMENSIONS

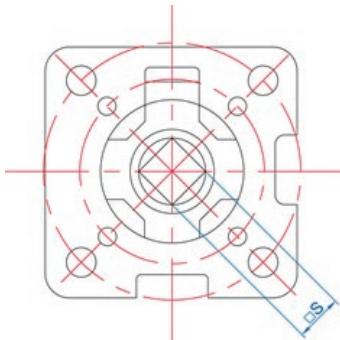

MEDIDA	DN	ISO 5211	S	TORQUE
SIZE	DN	ISO5211	S	Nm
1/4"	8	F03-F04	9x9	3-4
3/8"	10	F03-F04	9x9	3-4
1/2"	15	F03-F04	9x9	4-5
3/4"	20	F03-F04	9x9	5-7
1"	25	F04-F05	11x11	12-14
1 1/4"	32	F04-F05	11x11	12-14
1 1/2"	40	F05-F07	14x14	20-25
2"	50	F05-F07	14x14	25-30
2 1/2"	65	F07-F10	17x17	35-40
3"	80	F07-F10	17x17	60-65
4"	100	F07-F10	22x22	100-120

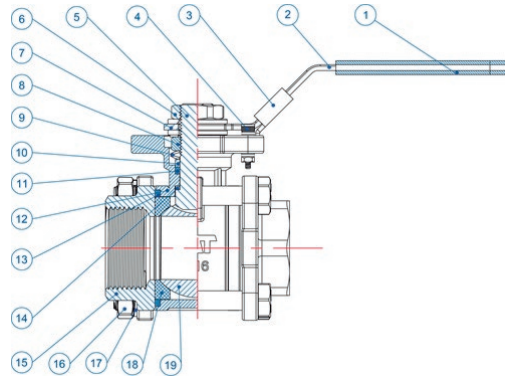

MATERIALES / MATERIALS

Nº	NOMBRE	MATERIALES	CALIDAD
Nº	NAME	MATERIALS	QUALITY
1	Cobertura maneta Handle cover	Plástico Plastic	PVC
2	Maneta Handle	Acero inoxidable Stainless steel	AISI 304
3	Mecanismo bloqueo Lock device	Acero inoxidable Stainless steel	AISI 304
4	Tornillo tope Stop bolt	Acero inoxidable Stainless steel	AISI 304
5	Eje Stem	Acero inoxidable Stainless steel	AISI 304
6	Tuerca Nut	Acero inoxidable Stainless steel	AISI 304
7	Arandela eje Stem washer	Acero inoxidable Stainless steel	AISI 304
8	Casquillo eje Stem bushing	Acero inoxidable Stainless steel	AISI 304
9	Arandela muelle Spring washer	Acero inoxidable Stainless steel	AISI 304
10	Prensaestopa Thrust washer	Acero inoxidable Stainless steel	AISI 304
11	Empaquetadura eje Packing	PTFE	PTFE
12	Cuerpo Body	Acero inoxidable Stainless steel	AISI 316
13	Junta cuerpo Body gasket	PTFE	PTFE
14	Cierre eje Stem seal	PTFE	PTFE
15	Tapa Cap	Acero inoxidable Stainless steel	AISI 316
16	Tuerca Nut	Acero inoxidable Stainless steel	AISI 304
17	Arandela Washer	Acero inoxidable Stainless steel	AISI 304
18	Asiento bola Ball seat	RPTFE	PTFE+FG
19	Bola Ball	Acero inoxidable Stainless steel	AISI 316

GRÁFICO PRESIÓN-TEMPERATURA / PRESSURE TEMPERATURE CHART

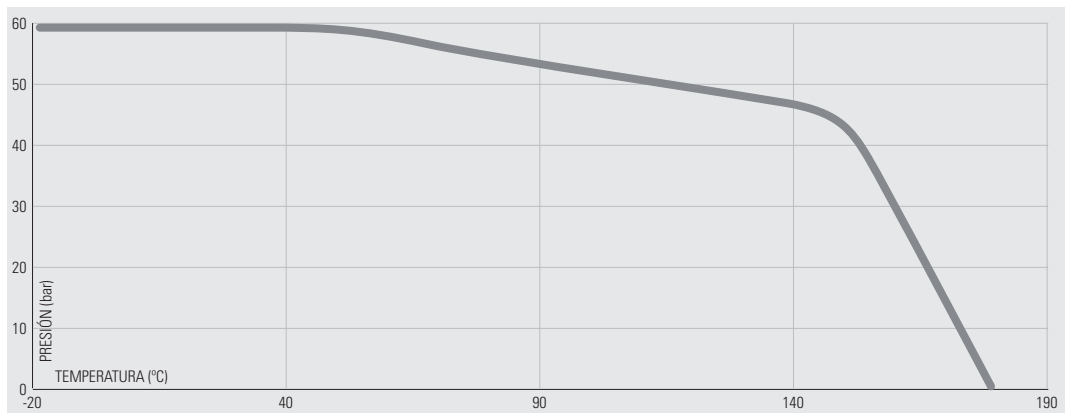

91020

VÁLVULA ESFERA TRES PIEZAS BUTT WELD PASO TOTAL PLETINA ISO
THREE PIECES BALL VALVE BUTT WELD FULL BORE MOUNTING PAD ISO

INOX

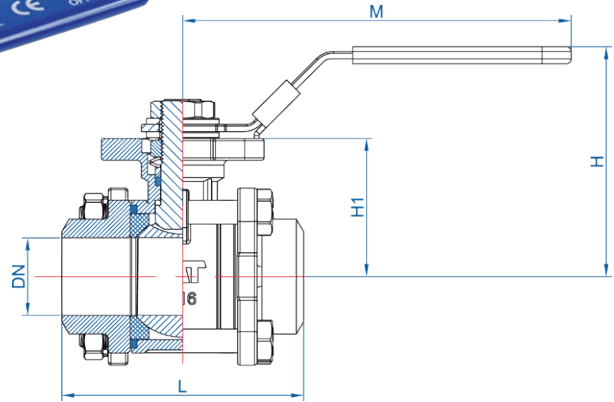
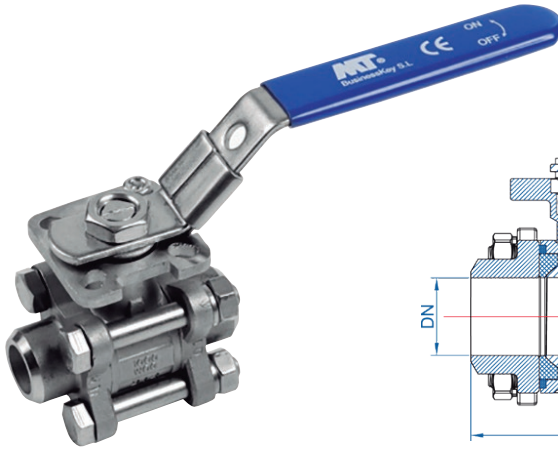

- Cuerpo y bola acero inoxidable CF8M (AISI-316)
Body and ball made of stainless steel CF8M (AISI-316)
- Asientos bola en PTFE reforzado
Reinforced PTFE ball seats
- Plataforma montaje directo ISO5211
Direct mounting Pad ISO 5211
- Presión máxima de trabajo: 63 Bar (1000 psi)
Max. working pressure: 63 Bar (1000 psi)
- Temperatura de trabajo: -20°C / 180°C
Working temperature: -20°C / 180°C
- Paso total
Full bore

DIMENSIONES / DIMENSIONS

CÓDIGO	MEDIDA	DN	L	H	H1	M	ISO 5211		€
CODE	SIZE	DN	L	H	H1	M	S	TORQUE	€
91020-015	1/2"	15	60	72	36,5	140	16	8	21,85
91020-020	3/4"	20	70	78	36,5	140	16	8	34,16
91020-025	1"	25	80	90	47,5	162	8	4	41,42
91020-032	1 1/4"	32	93	95	53	162	6	1	64,50
91020-040	1 1/2"	38	100	105	61,5	188	4	1	85,73
91020-050	2"	50	125	122	70,5	188	4	1	121,48
91020-065	2 1/2"	64	138	155	97	233	1	1	301,10

DIMENSIONES ISO 5211 / FLANGE ISO 5211 DIMENSIONS

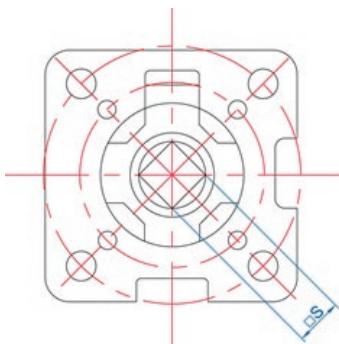

MEDIDA	DN	ISO 5211	S	TORQUE
SIZE	DN	ISO 5211	S	Nm
1/2"	15	F03-F04	9x9	4-5
3/4"	20	F03-F04	9x9	5-7
1"	25	F04-F05	11x11	12-14
1 1/4"	32	F04-F05	11x11	12-14
1 1/2"	40	F05-F07	14x14	20-25
2"	50	F05-F07	14x14	25-30
2 1/2"	65	F07-F10	17x17	35-40

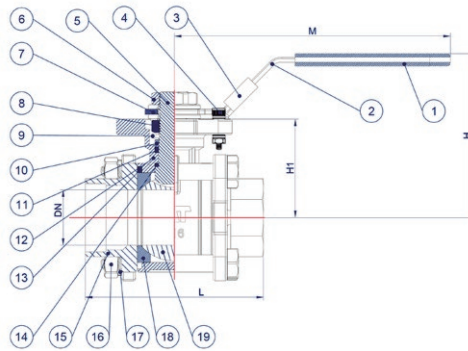

MATERIALES / MATERIALS

Nº	NOMBRE	MATERIALES	CALIDAD
Nº	NAME	MATERIALS	QUALITY
1	Cobertura maneta Handle cover	Plástico Plastic	PVC
2	Maneta Handle	Acero inoxidable Stainless steel	AISI 304
3	Mecanismo bloqueo Lock device	Acero inoxidable Stainless steel	AISI 304
4	Tornillo tope Stop bolt	Acero inoxidable Stainless steel	AISI 304
5	Eje Stem	Acero inoxidable Stainless steel	AISI 304
6	Tuerca Nut	Acero inoxidable Stainless steel	AISI 304
7	Arandela eje Stem washer	Acero inoxidable Stainless steel	AISI 304
8	Casquillo eje Stem bushing	Acero inoxidable Stainless steel	AISI 304
9	Arandela muelle Spring washer	Acero inoxidable Stainless steel	AISI 304
10	Prensaestopa Thrust washer	Acero inoxidable Stainless steel	AISI 304
11	Empaquetadura eje Packing	PTFE	PTFE
12	Cuerpo Body	Acero inoxidable Stainless steel	AISI 316
13	Junta cuerpo Body gasket	PTFE	PTFE
14	Cierre eje Stem seal	PTFE	PTFE
15	Tapa Cap	Acero inoxidable Stainless steel	AISI 316
16	Tuerca Nut	Acero inoxidable Stainless steel	AISI 304
17	Arandela Washer	Acero inoxidable Stainless steel	AISI 304
18	Asiento bola Ball seat	RPTFE	RPTFE
19	Bola Ball	Acero inoxidable Stainless steel	AISI 316

GRÁFICO PRESIÓN-TEMPERATURA / PRESSURE TEMPERATURE CHART

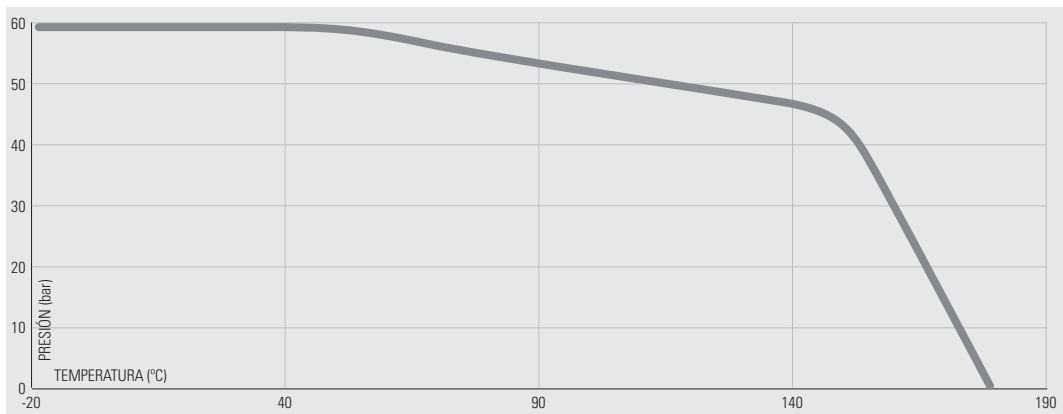

91120

VÁLVULA ESFERA TRES PIEZAS SOCKET WELD PASO TOTAL PLETINA ISO
THREE PIECES BALL VALVE SOCKET WELD FULL BORE MOUNTING PAD ISO

INOX

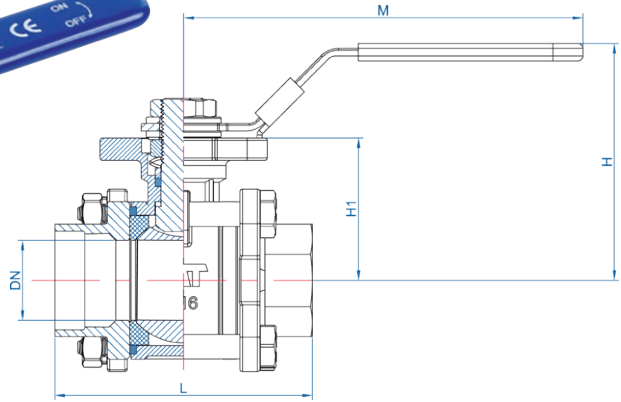
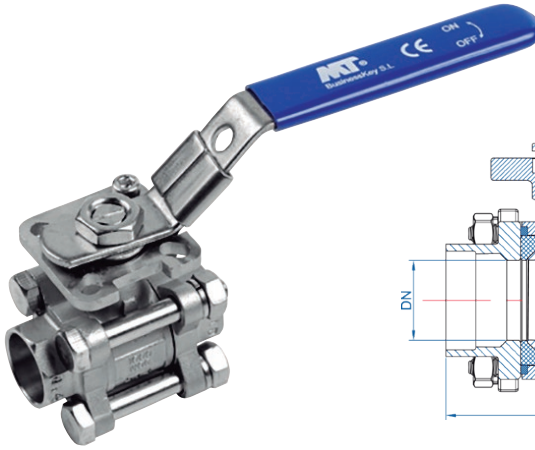

- **Cuerpo y bola acero inoxidable CF8M (AISI-316)**
Body and ball made of stainless steel CF8M (AISI-316)
- **Asientos bola en PTFE reforzado**
Reinforced PTFE ball seats
- **Plataforma montaje directo ISO5211**
Direct mounting Pad ISO 5211
- **Presión máxima de trabajo: 63 Bar (1000 psi)**
Max. Working pressure: 63 Bar (1000 psi)
- **Temperatura de trabajo: -20° / 180°C**
Working temperature: -20° / 180°C
- **Paso total**
Full bore

DIMENSIONES / DIMENSIONS

CÓDIGO	MEDIDA	DN	L	H	H1	M	ISO 5211		€
CODE	SIZE	DN	L	H	H1	M	S	S	€
91120-015	1/2"	15	60	72	36,5	140	16	8	21,85
91120-020	3/4"	20	70	78	36,5	140	16	8	34,16
91120-025	1"	25	80	90	47,5	162	8	4	41,42
91120-032	1 1/4"	32	93	95	53	162	6	1	64,50
91120-040	1 1/2"	38	100	105	61,5	188	4	1	85,73
91120-050	2"	50	125	122	70,5	188	4	1	121,48
91120-065	2 1/2"	64	138	155	97	233	1	1	301,10
91120-080	3"	-	-	-	-	-	2	1	418,19
91120-100	4"	-	-	-	-	-	1	1	588,94

DIMENSIONES ISO 5211 / FLANGE ISO 5211 DIMENSIONS

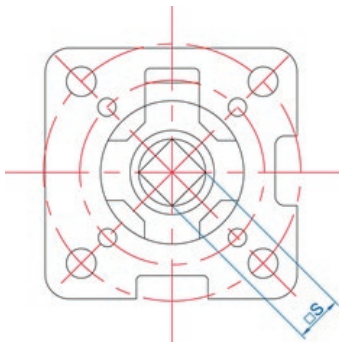

MEDIDA	DN	ISO 5211	S	TORQUE
SIZE	DN	ISO 5211	S	Nm
1/2"	15	F03-F04	9x9	4-5
3/4"	20	F03-F04	9x9	5-7
1"	25	F04-F05	11x11	12-14
1 1/4"	32	F04-F05	11x11	12-14
1 1/2"	40	F05-F07	14x14	20-25
2"	50	F05-F07	14x14	25-30
2 1/2"	65	F07-F10	17x17	35-40

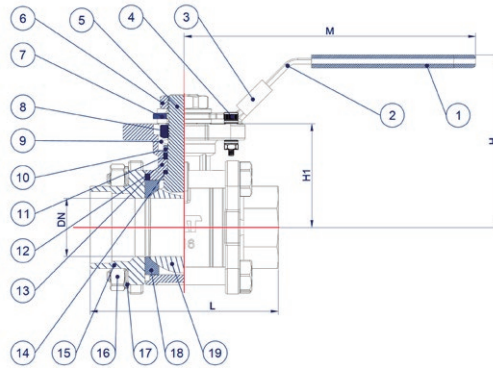

MATERIALES / MATERIALS

Nº	NOMBRE	MATERIALES	CALIDAD
Nº	NAME	MATERIALS	QUALITY
1	Cobertura maneta Handle cover	Plástico Plastic	PVC
2	Maneta Handle	Acero inoxidable Stainless steel	AISI 304
3	Mecanismo bloqueo Lock device	Acero inoxidable Stainless steel	AISI 304
4	Tornillo tope Stop bolt	Acero inoxidable Stainless steel	AISI 304
5	Eje Stem	Acero inoxidable Stainless steel	AISI 304
6	Tuerca Nut	Acero inoxidable Stainless steel	AISI 304
7	Arandela eje Stem washer	Acero inoxidable Stainless steel	AISI 304
8	Casquillo eje Stem bushing	Acero inoxidable Stainless steel	AISI 304
9	Arandela muelle Spring washer	Acero inoxidable Stainless steel	AISI 304
10	Prensaestopa Thrust washer	Acero inoxidable Stainless steel	AISI 304
11	Empaquetadura eje Packing	PTFE	PTFE
12	Cuerpo Body	Acero inoxidable Stainless steel	AISI 316
13	Junta cuerpo Body gasket	PTFE	PTFE
14	Cierre eje Stem seal	PTFE	PTFE
15	Tapa Cap	Acero inoxidable Stainless steel	AISI 316
16	Tuerca Nut	Acero inoxidable Stainless steel	AISI 304
17	Arandela Washer	Acero inoxidable Stainless steel	AISI 304
18	Asiento bola Ball seat	RPTFE	RPTFE
19	Bola Ball	Acero inoxidable Stainless steel	AISI 316

GRÁFICO PRESIÓN-TEMPERATURA / PRESSURE TEMPERATURE CHART

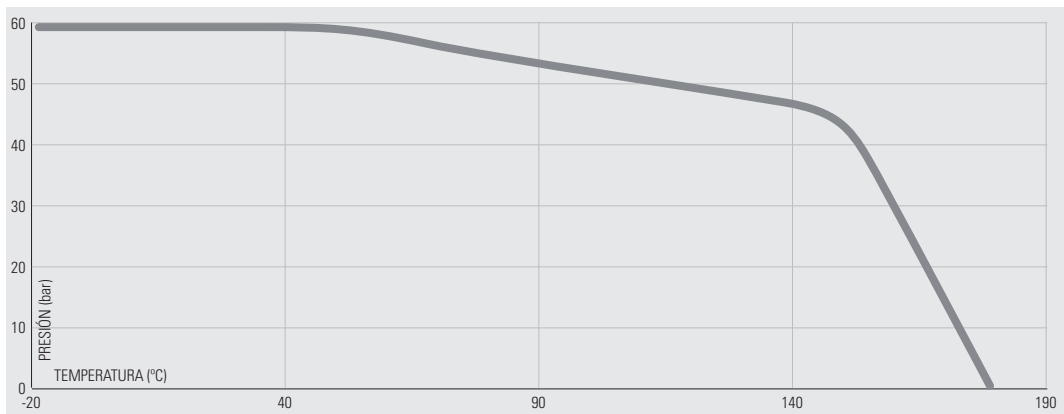

0918

VÁLVULA DE ESFERA TRES VÍAS PLETINA ISO PASO EN L THREE WAY BALL VALVE L-TYPE WITH MOUNTING PAD ISO

INOX

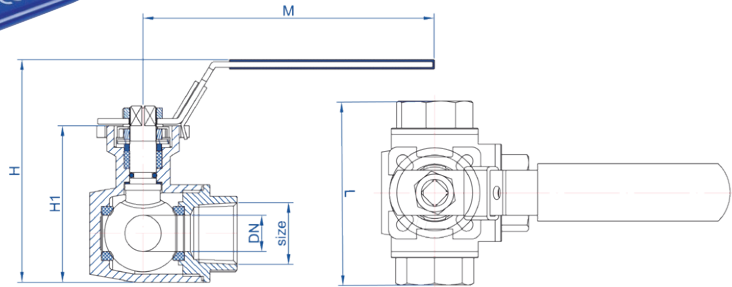

- Cuerpo fabricado en acero inoxidable CF8M (AISI-316)
Body made of stainless steel CF8M (AISI-316)
- Bola fabricada en acero inoxidable CF8M (AISI-316)
CF8M (AISI-316) stainless steel ball
- Asientos bola en PTFE
PTFE ball seats
- Roscas H-H BSP s/ norma ISO 228 (DIN 259)
F-F BSP Threads ISO 228 (DIN 259)
- Esfera con paso en L
L-Type bore ball
- Plataforma de montaje ISO5211
Direct mounting pad ISO5211
- Presión máxima de trabajo: 63 Bar (1000 psi)
Max. working pressure: 63 Bar (1000 psi)
- Temperatura de trabajo: -20°C / 100°C
Working temperature: -20°C / 100°C
- Paso reducido
Reduced bore

DIMENSIONES / DIMENSIONS

CÓDIGO CODE	MEDIDA SIZE	DN	L	H	H1	M			€
		DN	L	H	H1	M			€
0918-008	1/4"	12,5	79	57	42	132	8	4	50,23
0918-010	3/8"	12,5	79	57	42	132	8	4	50,90
0918-015	1/2"	12,5	79	57	42	132	8	4	52,52
0918-020	3/4"	16	83	64	49	134	8	4	63,24
0918-025	1"	20	104	74,5	59,5	165	6	3	88,75
0918-032	1 1/4"	25	111	78	63	170	5	1	117,68
0918-040	1 1/2"	32	126	88,5	73,5	197	3	1	168,77
0918-050	2"	38	147	97,8	82,8	200	2	1	241,01

DIMENSIONES ISO 5211 / FLANGE ISO 5211 DIMENSIONS

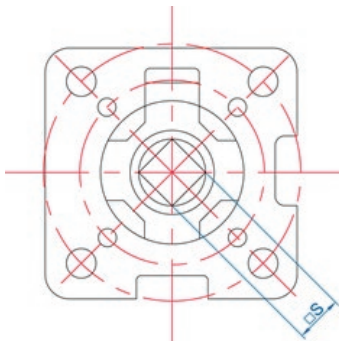

MEDIDA SIZE	DN	ISO 5211	S	TORQUE Nm
	DN	ISO 5211	S	
1/4"	8	F03-F04	9	7
3/8"	10	F03-F04	9	7
1/2"	15	F03-F04	9	7
3/4"	20	F03-F04	9	10
1"	25	F04-F05	11	15
1 1/4"	32	F04-F05	11	30
1 1/2"	40	F05-F07	14	30
2"	50	F05-F07	14	50

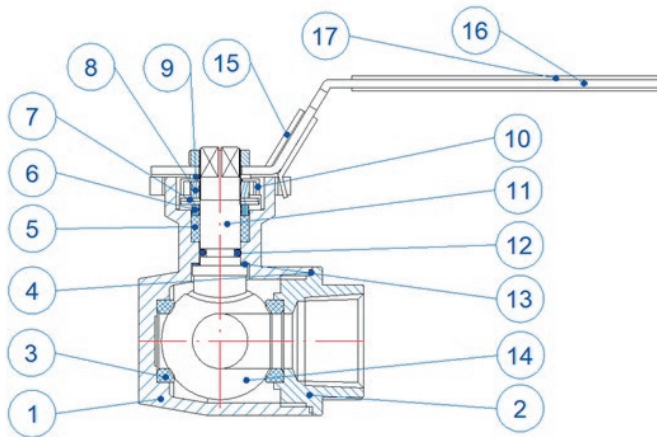

MATERIALES / MATERIALS

Nº	NOMBRE	MATERIALES	CALIDAD
Nº	NAME	MATERIALS	QUALITY
1	Cuerpo Body	Acero inoxidable Stainless steel	AISI 316
2	Tapa Cap	Acero inoxidable Stainless steel	AISI 316
3	Asiento Ball seat	RPTFE	RPTFE
4	Junta cuerpo Body seal	PTFE	PTFE
5	Empaquetadura eje Stem packing	PTFE	PTFE
6	Prensaestopa Gland nut	Acero inoxidable Stainless steel	AISI 304
7	Arandelas bellavile Spring washer	Acero inoxidable Stainless steel	AISI 301
8	Tuerca Nut	Acero inoxidable Stainless steel	AISI 304
9	Arandela Washer	Acero inoxidable Stainless steel	AISI 304
10	Arandela empuje Thrust washer	Acero inoxidable Stainless steel	AISI 304
11	Eje Stem	Acero inoxidable Stainless steel	AISI 304
12	Junta tórica O-ring	NBR	NBR
13	Junta eje Stem seal	PTFE	PTFE
14	Bola Ball	Acero inoxidable Stainless steel	AISI 316
15	Mecanismo bloqueo Lock device	Acero inoxidable Stainless steel	AISI 304
16	Maneta Handle	Acero inoxidable Stainless steel	AISI 304
17	Cobertura maneta Handle cover	Plástico Plastic	PVC

GRÁFICO PRESIÓN-TEMPERATURA / PRESSURE TEMPERATURE CHART

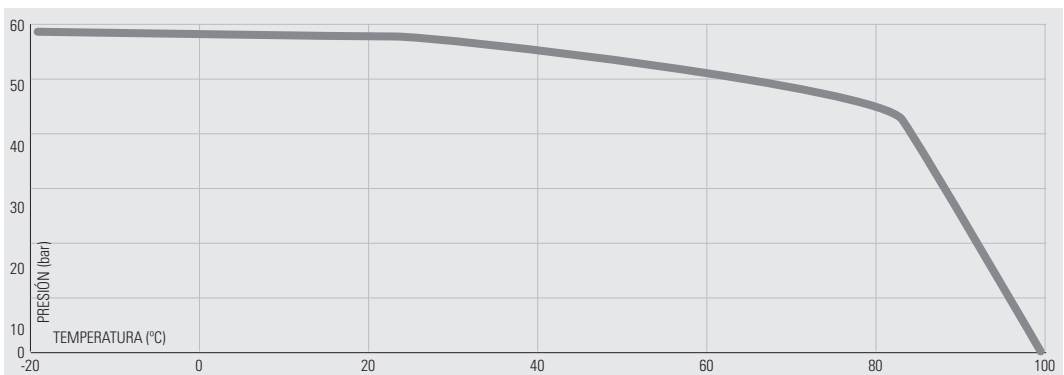

0919

VÁLVULA DE ESFERA TRES VÍAS PLETINA ISO PASO EN T
THREE WAY BALL VALVE T-TYPE WITH MOUNTING PAD ISO

INOX

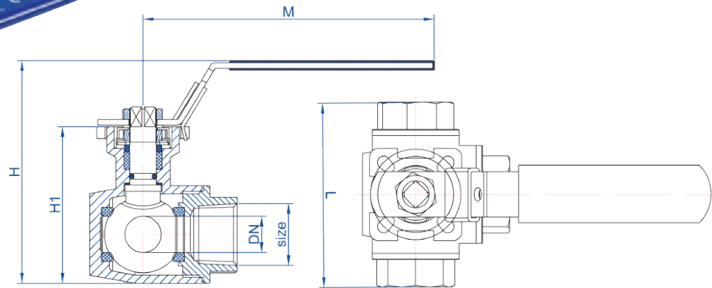
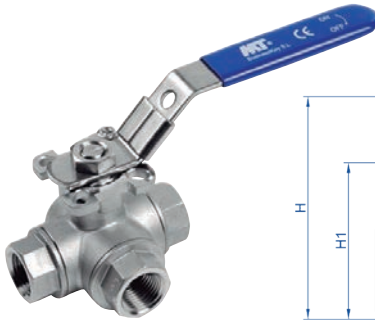

- Cuerpo fabricado en acero inoxidable CF8M (AISI-316)
Body made of stainless steel CF8M (AISI-316)
- Bola fabricada en acero inoxidable CF8M (AISI-316)
CF8M (AISI-316) stainless steel ball
- Asientos bola en PTFE
PTFE ball seats
- Roscas H-H BSP s/ norma ISO 228 (DIN 259)
F-F BSP Threads ISO 228 (DIN 259)

- Esfera con paso en T
T-Type bore ball
- Plataforma de montaje ISO5211
Direct mounting pad ISO5211
- Presión máxima de trabajo: 63 Bar (1000 psi)
Max. working pressure: 63 Bar (1000 psi)
- Temperatura de trabajo: -20°C / 100°C
Working temperature: -20°C / 100°C
- Paso reducido
Reduced bore

DIMENSIONES / DIMENSIONS

CÓDIGO CODE	MEDIDA SIZE	DN	L	H	H1	M			€
0919-008	1/4"	12,5	79	57	42	132	8	4	50,23
0919-010	3/8"	12,5	79	57	42	132	8	4	50,90
0919-015	1/2"	12,5	79	57	42	132	8	4	52,52
0919-020	3/4"	16	83	64	49	134	8	4	63,24
0919-025	1"	20	104	74,5	59,5	165	6	3	88,75
0919-032	1 1/4"	25	111	78	63	170	5	1	117,68
0919-040	1 1/2"	32	126	88,5	73,5	197	3	1	168,77
0919-050	2"	38	147	97,8	82,8	200	2	1	241,01

DIMENSIONES ISO 5211 / FLANGE ISO 5211 DIMENSIONS

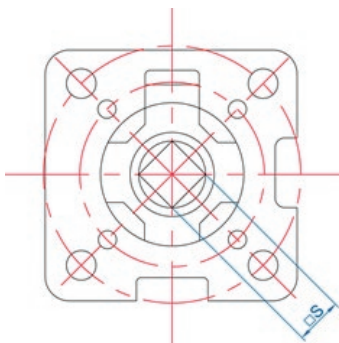

MEDIDA SIZE	DN	ISO 5211	S	TORQUE Nm
1/4"	8	F03-F04	9	7
3/8"	10	F03-F04	9	7
1/2"	15	F03-F04	9	7
3/4"	20	F03-F04	9	10
1"	25	F04-F05	11	15
1 1/4"	32	F04-F05	11	30
1 1/2"	40	F05-F07	14	30
2"	50	F05-F07	14	50

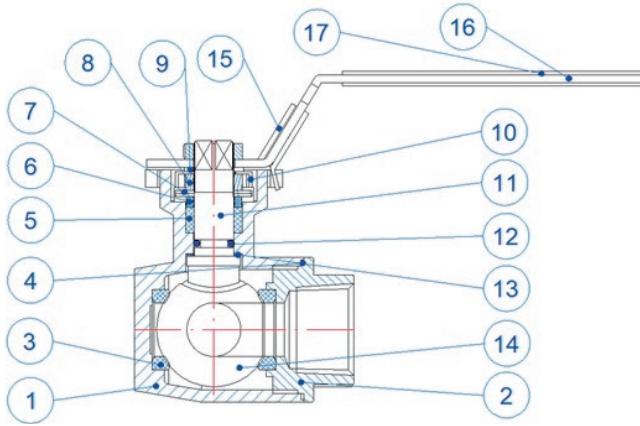

MATERIALES / MATERIALS

Nº	NOMBRE	MATERIALES	CALIDAD
Nº	NAME	MATERIALS	QUALITY
1	Cuerpo Body	Acero inoxidable Stainless steel	AISI 316
2	Tapa Cap	Acero inoxidable Stainless steel	AISI 316
3	Asiento Ball seat	PTFE	PTFE
4	Junta cuerpo Body seal	PTFE	PTFE
5	Empaquetadura eje Stem packing	PTFE	PTFE
6	Prensaestopa Gland nut	Acero inoxidable Stainless steel	AISI 304
7	Arandelas belleville Spring washer	Acero inoxidable Stainless steel	AISI 301
8	Tuerca Nut	Acero inoxidable Stainless steel	AISI 304
9	Arandela Washer	Acero inoxidable Stainless steel	AISI 304
10	Arandela empuje Thrust washer	Acero inoxidable Stainless steel	AISI 304
11	Eje Stem	Acero inoxidable Stainless steel	AISI 304
12	Junta tórica O-ring	NBR	NBR
13	Junta eje Stem seal	PTFE	PTFE
14	Bola Ball	Acero inoxidable Stainless steel	AISI 316
15	Mecanismo bloqueo Lock device	Acero inoxidable Stainless steel	AISI 304
16	Maneta Handle	Acero inoxidable Stainless steel	AISI 304
17	Cobertura maneta Handle cover	Plástico Plastic	PVC

GRÁFICO PRESIÓN-TEMPERATURA / PRESSURE TEMPERATURE CHART

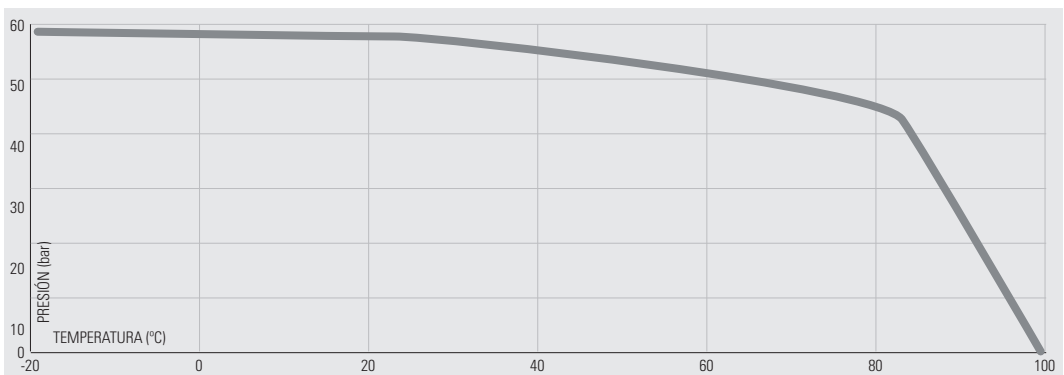

91031

VÁLVULA ESFERA WAFER PASO TOTAL CON PLETINA ISO
WAFER FULL BORE BALL VALVE WITH MOUNTING PAD ISO

INOX

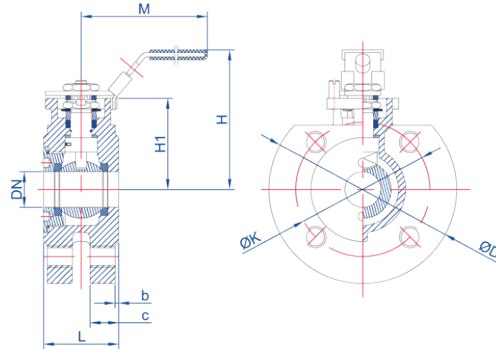

- **Cuerpo y bola acero inoxidable CF8M (AISI-316)**
Body and ball made of stainless steel CF8M (AISI-316)
- **Asientos bola en PTFE**
PTFE ball seats
- **Juntas tóricas de FKM**
FKM O-rings

- **Brida EN-1092**
EN-1092 flanges
- **Plataforma de montaje ISO 5211**
Direct mounting pad ISO 5211
- **Presión máxima de trabajo: 16 Bar**
Max. working pressure: 16 Bar
- **Temperatura de trabajo: -20°C / 180°C**
Working temperature: -20°C / 180°C

DIMENSIONES / DIMENSIONS

CÓDIGO	MEDIDA	DN	L	H	H1	ØD	ØK	M	TORN			€
CODE	SIZE	DN	L	H	H1	ØD	ØK	M	BOLTS			€
91031-015	1/2"	15	42	76	46,5	95	65	110	4XM14	18	9	78,84
91031-020	3/4"	20	42	81	53,5	105	75	110	4XM14	14	7	96,86
91031-025	1"	25	50	90	60	115	85	160	4XM14	12	6	116,22
91031-032	1 1/4"	32	60	102	72	140	100	160	4XM18	6	3	176,99
91031-040	1 1/2"	38	65	115	78	150	110	185	4XM18	1	1	227,95
91031-050	2"	48	80	122	85	165	125	185	4XM18	1	1	286,93
91031-065	2 1/2"	65	110	173	104	185	145	305	4XM18	1	1	461,87
91031-080	3"	78	120	184	115	200	160	305	8XM18	1	1	579,71
91031-100	4"	100	150	190	122	220	180	305	8XM18	1	1	814,55

DIMENSIONES ISO 5211 / FLANGE ISO 5211 DIMENSIONS

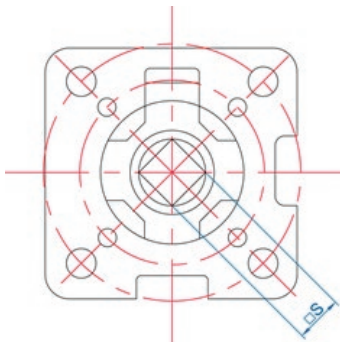

MEDIDA	DN	ISO 5211	S	TORQUE
SIZE	DN	ISO 5211	S	Nm
1/2"	15	F03-F04	9	4 – 5
3/4"	20	F03-F04	9	5 – 6
1"	25	F04-F05	11	12 – 15
1 1/4"	32	F04-F05	11	13 – 16
1 1/2"	40	F05-F07	14	21 – 25
2"	50	F05-F07	14	23 – 28
2 1/2"	65	F07-F10	17	35 – 39
3"	80	F07-F10	17	50 – 65
4"	100	F10	19	85 – 100

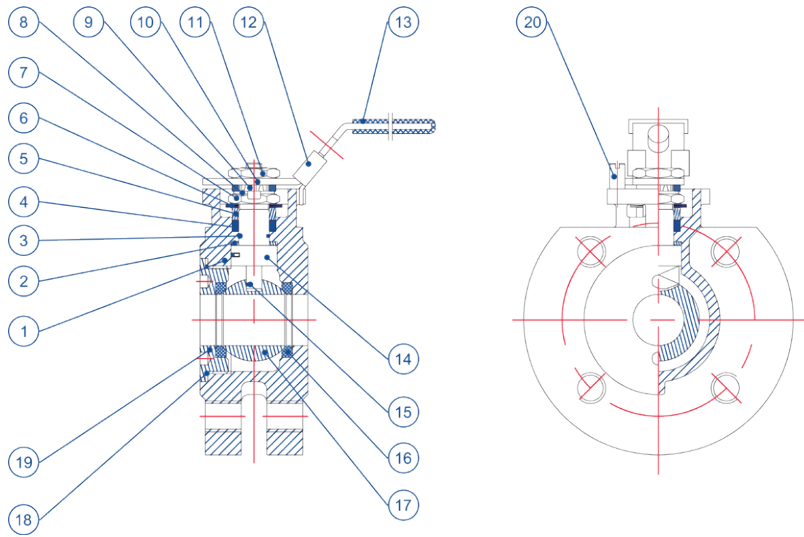

MATERIALES / MATERIALS

Nº	NOMBRE	MATERIALES
Nº	NAME	MATERIALS
1	Cuerpo Body	A316
2	Arandela de empuje Thrust washer	PTFE
3	Junta tórica O'Ring	FKM
4	Empaquetadura anillo V-Ring Packing	PTFE
5	Cierre Gland	A304
6	Arandela Washer	A301
7	Tuerca tope Stop nut	A194-8
8	Tapa válvula Stop cap	A301
9	Arandela Washer	A304
10	Maneta Handle	A304
11	Tuerca eje Stem nut	A304
12	Dispositivo bloqueo Locking device	A301
13	Funda Handle cover	Plástico Plastic
14	Eje Stem	A316
15	Sistema Anti-Static Anti-Static system	A316
16	Asiento bola Ball seat	PTFE
17	Bola Ball	A316
18	Junta cuerpo Body gasket	PTFE
19	Cap Tapa	A316
20	Tornillo posición Position bolt	A304

91032

VÁLVULA ESFERA WAFER PASO TOTAL CON PLETINA ISO CON CÁMARA CALEFACCIÓN
WAFER FULL BORE BALL VALVE WITH MOUNTING PAD ISO & HEAT CHAMBER

INOX

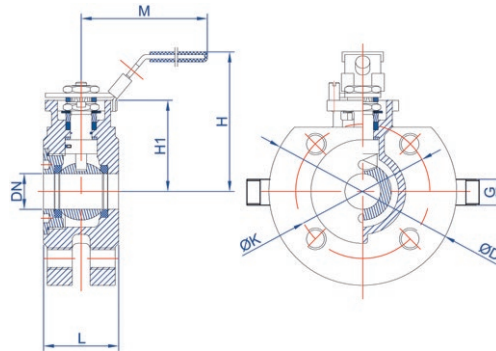

- Cuerpo y bola acero inoxidable CF8M (AISI-316)
Body and ball made of stainless steel CF8M (AISI-316)
- Asientos bola en PTFE
PTFE ball seats
- Juntas tóricas de FKM
FKM O-rings
- Cámara de calefacción INOX. (AISI-316)
Heat chamber of S.S. (AISI-316)

- Tomas 3/4" hembra
Head threads 3/4" female
- Brida EN-1092
EN-1092 flanges
- Plataforma de montaje ISO 5211
Direct mounting pad ISO 5211
- Presión máxima de trabajo: 16 Bar
Max. working pressure: 16 Bar
- Temperatura de trabajo: -20°C / 180°C
Working temperature: -20°C / 180°C

DIMENSIONES / DIMENSIONS

CÓDIGO	MEDIDA	DN	L	H	H1	ØD	ØK	M	TORN			€
CODE	SIZE	DN	L	H	H1	ØD	ØK	M	BOLTS			€
91032-015	1/2"	15	42	76	46,5	95	65	110	4XM14	1	1	322,47
91032-020	3/4"	20	42	81	53,5	105	75	110	4XM14	1	1	340,49
91032-025	1"	25	50	90	60	115	85	160	4XM14	1	1	359,85
91032-032	1 1/4"	32	60	102	72	140	100	160	4XM18	1	1	446,86
91032-040	1 1/2"	38	65	115	78	150	110	185	4XM18	1	1	497,81
91032-050	2"	48	80	122	85	165	125	185	4XM18	1	1	571,79
91032-065	2 1/2"	65	110	173	104	185	145	305	4XM18	1	1	776,71
91032-080	3"	78	120	184	115	200	160	305	8XM18	1	1	939,53
91032-100	4"	100	150	190	122	220	180	305	8XM18	1	1	1.249,33

DIMENSIONES ISO 5211 / FLANGE ISO 5211 DIMENSIONS

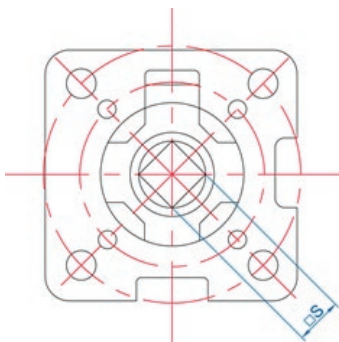

MEDIDA	DN	ISO 5211	S	TORQUE
SIZE	DN	ISO 5211	S	Nm
1/2"	15	F03-F04	9	4 – 5
3/4"	20	F03-F04	9	5 – 6
1"	25	F04-F05	11	12 – 15
1 1/4"	32	F04-F05	11	13 – 16
1 1/2"	40	F05-F07	14	21 – 25
2"	50	F05-F07	14	23 – 28
2 1/2"	65	F07-F10	17	35 – 39
3"	80	F07-F10	17	50 – 65
4"	100	F10	19	85 – 100

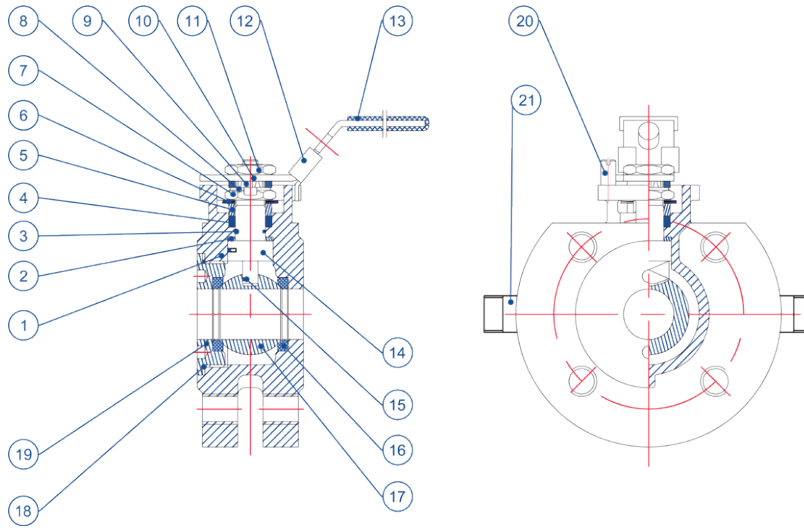

MATERIALES / MATERIALS

Nº	NOMBRE	MATERIALES	CALIDAD
Nº	NAME	MATERIALS	QUALITY
1	Cuerpo Body	Acero inoxidable Stainless steel	A316
2	Arandela de empuje Thrust washer	PTFE	PTFE
3	Junta tórica O'Ring	FKM	FKM
4	Empaquetadura anillo V-Ring Packing	PTFE	PTFE
5	Cierre Gland	Acero inoxidable Stainless steel	A304
6	Arandela Washer	Acero inoxidable Stainless steel	A301
7	Tuerca tope Stop nut	Acero inoxidable Stainless steel	A194-8
8	Tapa válvula Stop cap	Acero inoxidable Stainless steel	A301
9	Arandela Washer	Acero inoxidable Stainless steel	A304
10	Maneta Handle	Acero inoxidable Stainless steel	A304
11	Tuerca eje Stem nut	Acero inoxidable Stainless steel	A304
12	Dispositivo bloqueo Locking device	Acero inoxidable Stainless steel	A301
13	Funda Handle cover	Plástico Plastic	PVC
14	Eje Stem	Acero inoxidable Stainless steel	A316
15	Sistema Anti-Static Anti-Static System	Acero inoxidable Stainless steel	A316
16	Asiento bola Ball seat	PTFE	PTFE
17	Bola Ball	Acero inoxidable Stainless steel	A316
18	Junta cuerpo Body gasket	PTFE	PTFE
19	Tapa Cap	Acero inoxidable Stainless steel	A316
20	Tornillo posición Position bolt	Acero inoxidable Stainless steel	A304
21	Cámara calefactable Heating chamber	Acero inoxidable Stainless steel	A316

0914

VÁLVULA ESFERA MINI PASO REDUCIDO PN-63 H-H
F-F REDUCED BORE BALL VALVE PN-63

INOX

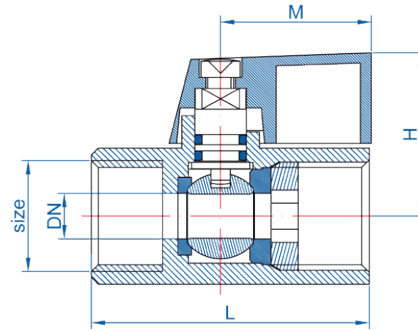

- Cuerpo fabricado en acero inoxidable CF8M (AISI-316)
Body made of stainless steel CF8M (AISI-316)
- Bola fabricada en acero inoxidable CF8M (AISI-316)
CF8M (AISI-316) stainless steel ball
- Asientos bola en PTFE
PTFE ball seats

- Rosca S/ DIN 2999/259
Thread according to DIN2999/259
- Presión máxima de trabajo: 63 Bar (PN-63)
Max. working pressure: 63 Bar (PN-63)
- Temperatura de trabajo: -20°C / 180°C
Working temperature: -20°C / 180°C

DIMENSIONES / DIMENSIONS

CÓDIGO	MEDIDA	DN	L	H	M			€
CODE	SIZE	DN	L	H	M			€
0914-008	1/4"	7	42	26,5	22,8	120	60	10,16
0914-010	3/8"	7	42	26,5	22,8	120	60	10,63
0914-015	1/2"	9,2	46	28,3	22,8	100	50	12,15

MATERIALES / MATERIALS

Nº	NOMBRE	MATERIALES
Nº	NAME	MATERIALS
1	Vástago Stem	SS 304
2	J. Tórica O-Ring	NBR
3	Tornillo Bolt	SS 304
4	Palanca Handle	Aluminium
5	Cuerpo Body	CF8M
6	Tapón Cap	CF8M
7	Asiento A Seat A	PTFE
8	Bola Ball	CF8M
9	Asiento B Seat B	PTFE

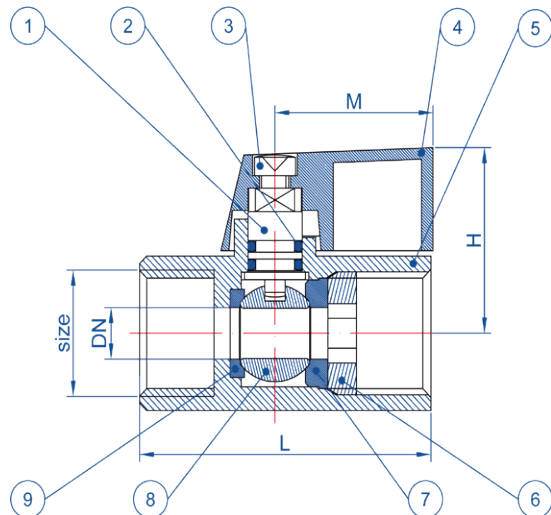

0915

VÁLVULA ESFERA MINI PASO REDUCIDO PN-63 M-H
M-F REDUCED BORE BALL VALVE PN-63

INOX

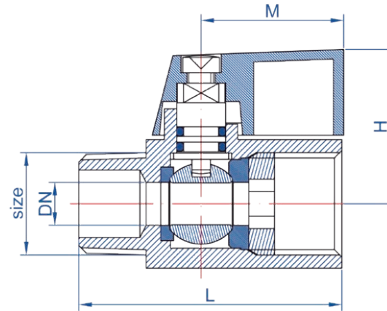

- Cuerpo fabricado en acero inoxidable CF8M (AISI-316)
Body made of stainless steel CF8M (AISI-316)
- Bola fabricada en acero inoxidable CF8M (AISI-316)
CF8M (AISI-316) stainless steel ball
- Asientos bola en PTFE
PTFE ball seats

- Rosca S/ DIN 2999/259
Thread according to DIN2999/259
- Presión máxima de trabajo: 63 Bar (PN-63)
Max. working pressure: 63 Bar (PN-63)
- Temperatura de trabajo: -20°C / 180°C
Working temperature: -20°C / 180°C

DIMENSIONES / DIMENSIONS

CÓDIGO	MEDIDA	DN	L	H	M			€
CODE	SIZE	DN	L	H	M			€
0915-008	1/4"	7	42	26,5	22,8	120	60	10,56
0915-010	3/8"	7	42	26,5	22,8	120	60	11,05
0915-015	1/2"	9,2	46	28,3	22,8	100	50	12,64

MATERIALES / MATERIALS

Nº	NOMBRE	MATERIALES
Nº	NAME	MATERIALS
1	Vástago Stem	SS 304
2	J. Tórica O-Ring	NBR
3	Tornillo Bolt	SS 304
4	Palanca Handle	Aluminium
5	Cuerpo Body	CF8M
6	Tapón Cap	CF8M
7	Asiento A Seat A	PTFE
8	Bola Ball	CF8M
9	Asiento B Seat B	PTFE

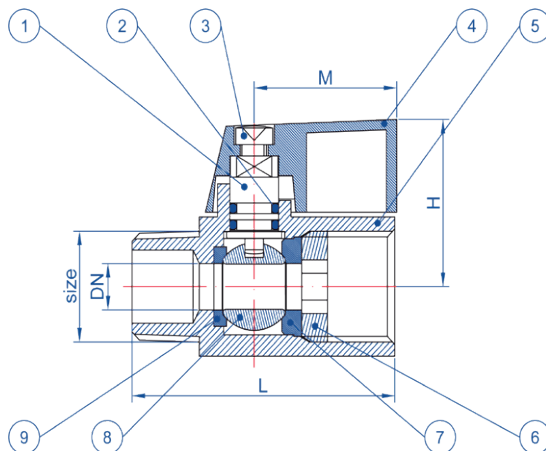

0921

GRIFO ESFERA JARDÍN ENCHUFE MANGUERA PN-16 INOXIDABLE
STAINLESS STEEL BIB COCK GARDEN PN-16 HOSE CONNECTOR

INOX

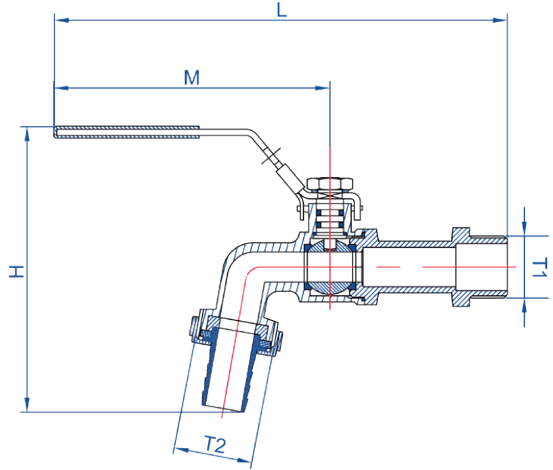

- **Cuerpo, tapa, bola y conexión manguera en acero inoxidable AISI-316**
Body, bonnet, ball and hose connection made of stainless steel AISI-316
- **Maneta y mecanismo de bloqueo en AISI-304**
Handle and lock device made of stainless steel AISI-304
- **Asientos bola en PTFE**
PTFE ball seats

- **Rosca s/ ISO 228/1 (DIN 259)**
Thread according to ISO 228/1 (DIN259)
- **Presión máxima de trabajo: 16 Bar**
Max. working pressure: 16 Bar
- **Temperatura de trabajo: -10°C / 100°C**
Working temperature: -10°C / 100°C

DIMENSIONES / DIMENSIONS

CÓDIGO	MEDIDA	T1	T2	L	H	M			€
CODE	SIZE	T1	T2	L	H	M			€
0921-015	1/2" x 3/4"	1/2"	3/4"	145	87	92	30	15	13,98
0921-020	3/4" x 3/4"	3/4"	3/4"	155	87	92	20	10	15,88
0921-025	1" x 1"	1"	1"	185	120	115	10	5	23,21

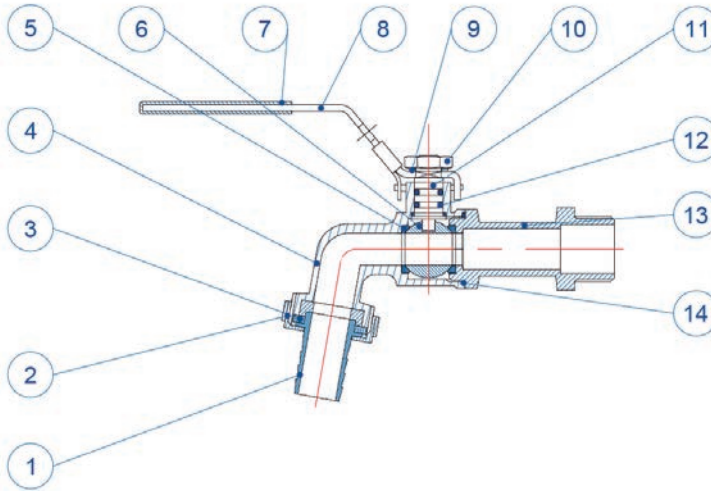

MATERIALES / MATERIALS

Nº	NOMBRE	MATERIALES	CALIDAD
Nº	NAME	MATERIALS	QUALITY
1	Salida Outlet	Acero inoxidable Stainless steel	A-316
2	Tuerca Nut	Acero inoxidable Stainless steel	A-316
3	Junta conexión manguera Lat seal hose connection	Elastómero Rubber	NBR70
4	Cuerpo Body	Acero inoxidable Stainless steel	A-316
5	Asiento de bola Ball seat	Politetrafluoroetileno	PTFE
6	Bola Ball	Acero inoxidable Stainless steel	A-316
7	Funda maneta Handle cover	Plástico Plastic	PVC
8	Maneta + seguro Handle + lock	Acero inoxidable Stainless steel	A-304
9	Arandela Washer	Acero inoxidable Stainless steel	A-304
10	Tuerca eje Stem nut	Acero inoxidable Stainless steel	A-304
11	Eje Stem	Acero inoxidable Stainless steel	A-316
12	Juntas tóricas O-Ring	Elastómero Rubber	NBR70
13	Tapa Cap	Acero inoxidable Stainless steel	A-316
14	Junta plana Flat Joint	Politetrafluoroetileno	PTFE

0926

VÁLVULA BARRIL PARA DEPÓSITO
BARREL BALL VALVE

INOX

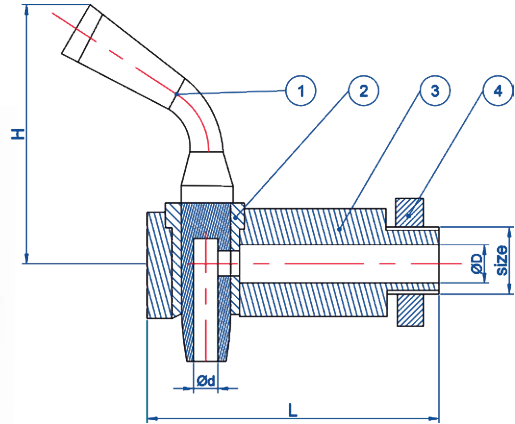
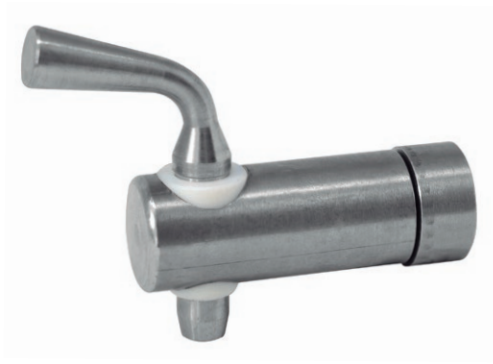

- **Cuerpo y maneta en acero inoxidable AISI-316**
Body and handle made of stainless steel AISI-316
- **Asientos bola en PTFE**
PTFE ball seats
- **Tuerca para soldar incluida**
Welding nut included
- **Presión máxima de trabajo: 6 Bar (100 psi)**
Max. working pressure: 6 Bar (100 psi)
- **Temperatura de trabajo: -20°C /180°C**
Working temperature: -20°C /180°C

CÓDIGO	MEDIDA	L	ØD	Ød	H	M			€
CODE	SIZE	L	ØD	Ød	H	M			€
0926-008	1/4"	57	7	5	36	40	100	50	6,97

MATERIALES / MATERIALS

Nº	NOMBRE	MATERIALES	CALIDAD
Nº	NAME	MATERIALS	QUALITY
1	Maneta Handle	Acero inoxidable Stainless steel	AISI 316
2	Asiento Seat	PTFE	PTFE
3	Cuerpo Body	Acero inoxidable Stainless steel	AISI 316
4	Nut Tuerca	Acero inoxidable Stainless steel	AISI 316

5132

VÁLVULA DE COMPUERTA INOXIDABLE CIERRE METÁLICO
METALLIC GATE VALVE STAINLESS STEEL

INOX

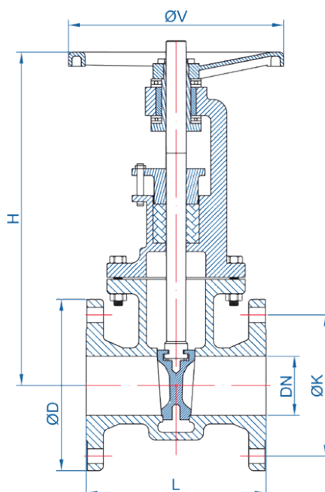

- Fabricado en acero inoxidable (AISI-316)
Made of stainless steel (AISI-316)
- Compuerta metálica INOX AISI-316
Stainless steel wedge AISI-316
- Eje de acero inoxidable (AISI-316)
Stainless steel stem (AISI-316)
- Bridas s/ UNE EN1092-2 PN-16
Flanges according to UNE EN1092-2 PN-16
- Presión máxima de trabajo: 16 Bar (PN-16)
Max. working pressure: 16 Bar (PN-16)
- Temperatura de trabajo: -20°C / 200°C
Working temperature: -20°C / 200°C

CÓDIGO	MEDIDA	DN	L	H	ØK	ØD	ØV	TORN	€
CODE	SIZE	DN	L	H	ØK	ØD	ØV	BOLTS	€
5132-040	1 1/2"	40	140	286	110	150	160	4XM16	1 Consultar
5132-050	2"	50	150	308	125	165	160	4XM18	1 Consultar
5132-065	2 1/2"	65	170	370	145	185	200	4XM18	1 Consultar
5132-080	3"	80	180	394	160	200	200	8XM20	1 Consultar
5132-100	4"	100	190	481	180	220	250	8XM20	1 Consultar
5132-125	5"	125	200	539	210	250	320	8XM22	1 Consultar
5132-150	6"	150	210	623	240	285	320	8XM22	1 Consultar
5132-200	8"	200	230	692	295	340	360	8XM24	1 Consultar

GRÁFICO PRESIÓN-TEMPERATURA / PRESSURE TEMPERATURE CHART

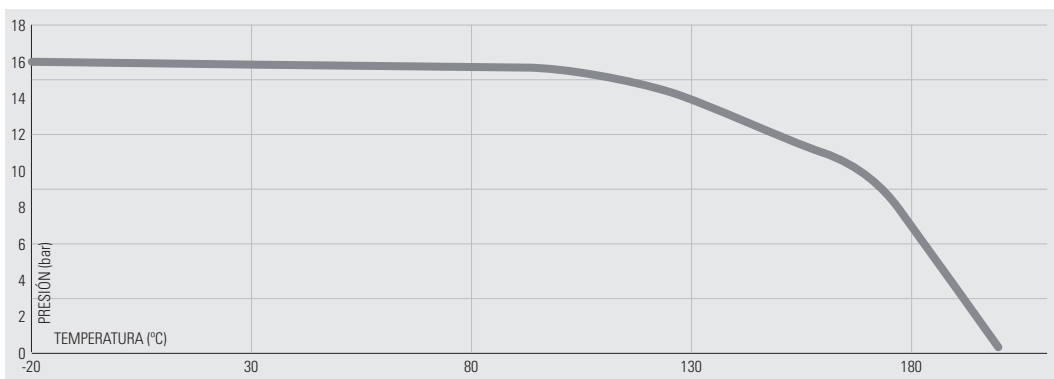

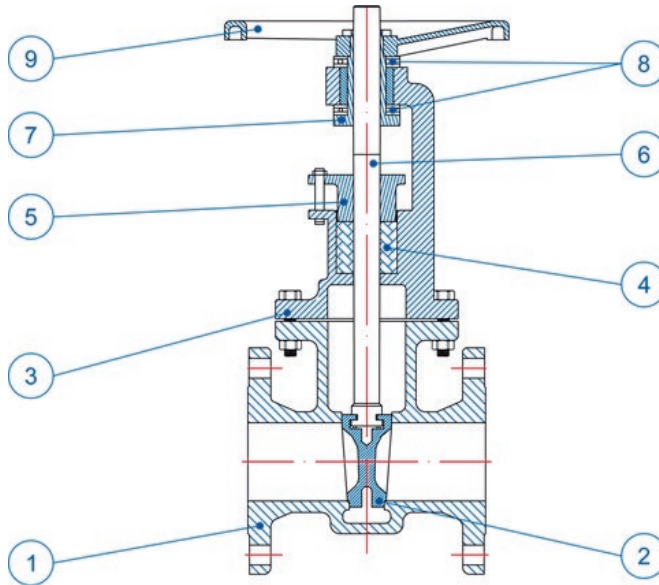

MATERIALES / MATERIALS

Nº	NOMBRE	MATERIALES	CALIDAD
Nº	NAME	MATERIALS	QUALITY
1	Cuerpo Body	Acero inoxidable Stainless steel	AISI 316
2	Compuerta Gate	Acero inoxidable Stainless steel	AISI 316
3	Tapa Bonnet	Acero inoxidable Stainless steel	AISI 316
4	Empaquetadura Packing Gland	Caucho Rubber	PTFE Grafito
5	Prensaestopa Gland	Acero inoxidable Stainless steel	AISI 316
6	Eje Stem	Acero inoxidable Stainless steel	AISI 316
7	Tuerca Nut	Bronce Bronze	-
8	Rodamientos Ball bearings	Acero Steel	AISI 52100
9	Volante Handwheel	Hierro fundido Cast iron	EN-GJL-250

310912

VÁLVULA DE TRES PIEZAS FONDO CUBA THREE PIECES TANK BOTTOM VALVE

INOX

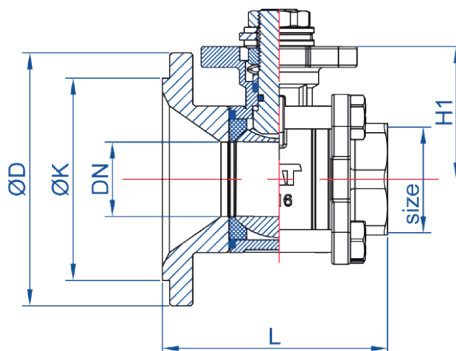
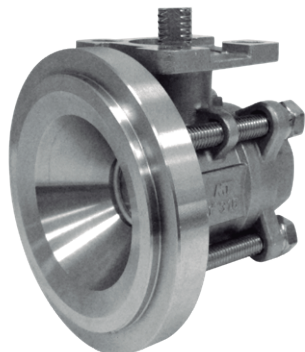

- Cuerpo fabricado en acero inoxidable CF8M (AISI-316)
Body made of stainless steel CF8M (AISI-316)
- Bola fabricada en acero inoxidable CF8M (AISI-316)
CF8M (AISI-316) stainless steel ball
- Asientos bola en PTFE
Reinforced PTFE ball seats
- Rosca H BSP s/ norma ISO 228/1 (DIN 2599)
F BSP Thread ISO 228/1 (DIN 2599)
- Brida conexión a depósito en acero inoxidable AISI-316L
S.S. tank bottom flange AISI-316L

- Plataforma montaje directo ISO5211
Direct mounting pad ISO 5211
- Paso total
Full bore
- Presión máxima de trabajo: 63 Bar (1000 psi)
Max. working pressure: 63 Bar (1000 psi)
- Temperatura de trabajo: -20°C / 180°C
Working temperature: -20°C / 180°C

DIMENSIONES / DIMENSIONS

CÓDIGO	MEDIDA	DN	ØD	ØK	L	H1	TORN			€
CODE	SIZE	DN	ØD	ØK	L	H1	BOLTS			€
310912-015	1/2"	15	70	60	66	42	4XM14	1	1	167,76
310912-020	3/4"	20	84	75	83	48	4XM14	1	1	216,67
310912-025	1"	25	95	80	83	55	4XM14	1	1	227,16
310912-032	1 1/4"	32	110	90	106	60	4XM18	1	1	406,65
310912-040	1 1/2"	38	130	110	110	70	4XM18	1	1	430,61
310912-050	2"	50	150	140	120	85	4XM18	1	1	556,86
310912-065	2 1/2"	65	185	175	160	109	4XM18	1	1	823,47
310912-080	3"	76	200	185	170	118	8XM18	1	1	1.022,81

DIMENSIONES ISO 5211 / FLANGE ISO 5211 DIMENSIONS

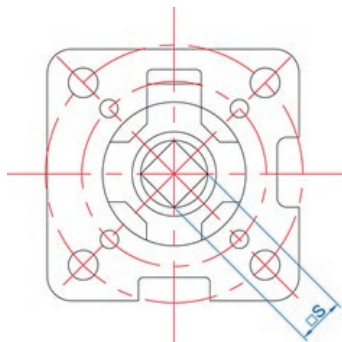

MEDIDA	DN	ISO 5211	S	TORQUE
SIZE	DN	ISO 5211	S	Nm
1/4"	8	F03-F04	9x9	3-4
3/8"	10	F03-F04	9x9	3-4
1/2"	15	F03-F04	9x9	4-5
3/4"	20	F03-F04	9x9	5-7
1"	25	F04-F05	11x11	12-14
1 1/4"	32	F04-F05	11x11	12-14
1 1/2"	40	F05-F07	14x14	20-25
2"	50	F05-F07	14x14	25-30
2 1/2"	65	F07-F10	17x17	35-40
3"	80	F07-F10	17x17	60-65

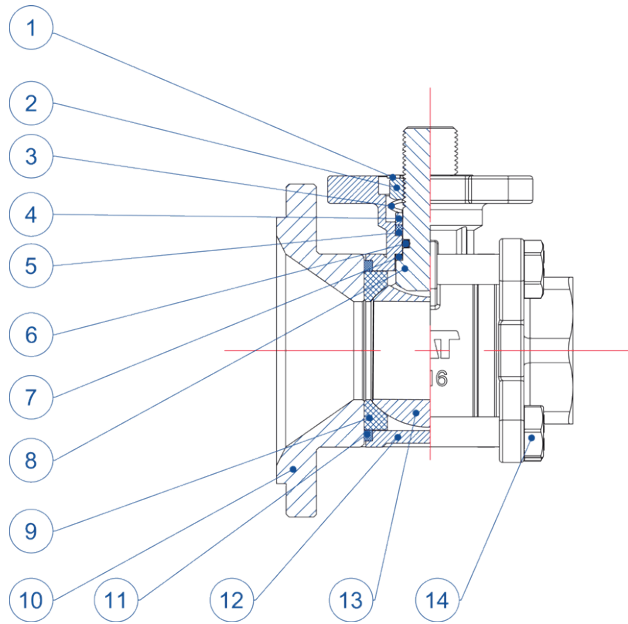

MATERIALES / MATERIALS

Nº	NOMBRE	MATERIALES	CALIDAD
Nº	NAME	MATERIALS	QUALITY
1	Arandela posicion Location washer	Acero inoxidable Stainless steel	AISI 304
2	Tuerca cierre Seal nut	Acero inoxidable Stainless steel	AISI 304
3	Arandela bellevile Spring washer	Acero inoxidable Stainless steel	AISI 304
4	Prensaestopa Packing gland	Acero inoxidable Stainless steel	AISI 304
5	Empaquetadura eje Stem packing	PTFE	PTFE
6	Junta tórica O-ring	FKM	FKM
7	Junta eje Stem gasket	PTFE	PTFE
8	Eje Stem	Acero inoxidable Stainless steel	AISI 304
9	Asiento bola Ball seat	PTFE	PTFE
10	Brida depósito Tank flange	Acero inoxidable Stainless steel	AISI 316
11	Junta cuerpo Body gasket	PTFE	PTFE
12	Cuerpo Body	Acero inoxidable Stainless steel	AISI 316
13	Bola Ball	Acero inoxidable Stainless steel	AISI 316
14	Tornillo Stud	Acero inoxidable Stainless steel	AISI 304

5117

VÁLVULA ESFERA DOS PIEZAS ACERO AL CARBONO CON BRIDAS TWO PIECES BALL VALVE WCB FLANGED END

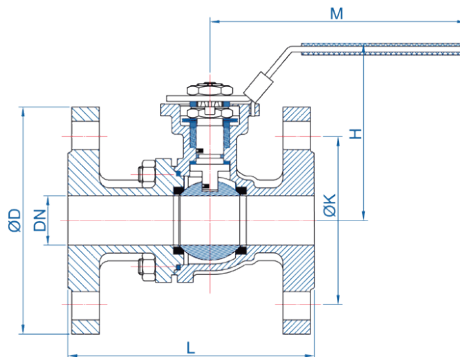

- Cuerpo fabricado en acero al carbono (A-276 WCB)
Body made of carbon steel (A-276 WCB)
- Bola fabricada en acero inoxidable
Stainless steel ball
- Asientos de bola de PTFE reforzado con grafito
Ball seats made of reinforced PTFE with graphite
- Juntas en PTFE
PTFE seat gaskets

- Juntas tóricas eje FKM
FKM stem O-rings
- Bridas s/ UNE EN-1092-2 PN-16
Flanges according to UNE EN-1092-2 PN-16
- Presión máxima de trabajo: 16 Bar
Max. working pressure: 16 Bar
- Temperatura de trabajo: -20°C / 180°C
Working temperature: -20°C / 180°C
- Paso total
Full bore

DIMENSIONES / DIMENSIONS

CÓDIGO CODE	MEDIDA SIZE	DN	L	H	ØD	ØK	M	TORN BOLTS	€
5117-015	1/2"	15	115	76	95	65	110	4XM14 18	52,86
5117-020	3/4"	20	120	81	105	75	110	4XM14 15	64,00
5117-025	1"	25	125	90	115	85	160	4XM14 1	83,03
5117-032	1 1/4"	32	130	102	140	100	160	4XM18 1	106,38
5117-040	1 1/2"	40	140	115	150	110	185	4XM18 1	138,85
5117-050	2"	50	150	122	165	125	185	4XM18 1	167,30
5117-065	2 1/2"	65	170	168	185	145	305	4XM18 1	235,87
5117-080	3"	80	180	178	200	160	305	8XM18 1	296,36
5117-100	4"	100	190	198	220	180	305	8XM18 1	387,60
5117-125	5"	125	325	234	250	210	500	8XM18 1	751,25
5117-150	6"	150	350	288	285	240	645	8XM22 1	1.078,13

DIMENSIONES ISO 5211 FLANGE ISO 5211 DIMENSIONS

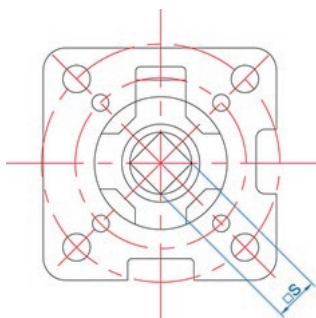

MEDIDA SIZE	DN	ISO 5211	h	S	TORQUE Nm
1/2"	15	F03-F04	8,5	9x9	4
3/4"	20	F03-F04	8,5	9x9	6,5
1"	25	F04-F05	10	11x11	8
1 1/4"	32	F04-F05	10	11x11	14
1 1/2"	38	F05-F07	14	14x14	20
2"	50	F05-F07	14	14x14	26
2 1/2"	65	F07-F10	16	17x17	45
3"	80	F07-F10	16	17x17	74
4"	100	F07-F10	18	19x19	103
5"	125	F10-F12	22	27x27	300
6"	150	F10-F12	22	27x27	400

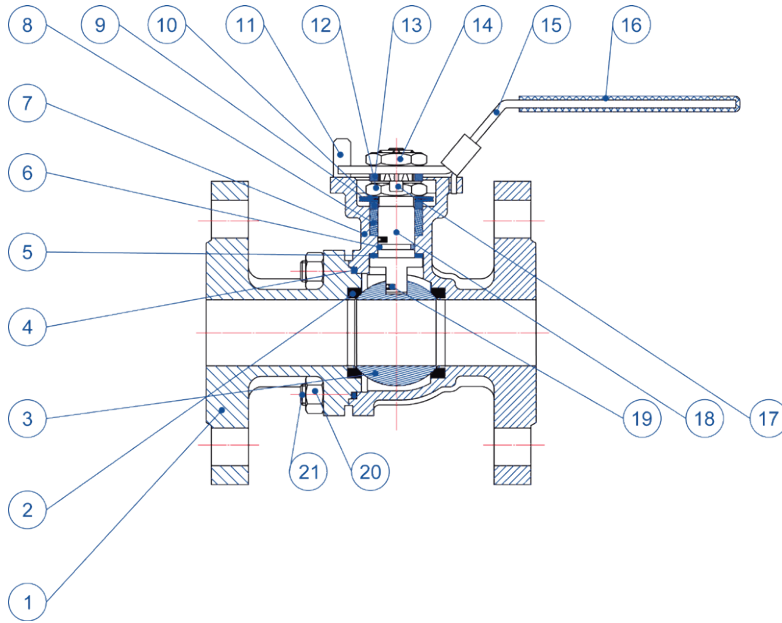

MATERIALES / MATERIALS

Nº	NOMBRE	MATERIALES	CALIDAD
Nº	NAME	MATERIALS	QUALITY
1	Tapa Bonnet	Acero al carbono Carbon Steel	ASTM A276 WCB
2	Alojamiento bola Ball seat	PTFE + grafito PTFE + graphite	PTFE + grafito PTFE + graphite
3	Bola Ball	Acero inoxidable Stainless steel	ASTM A276 A304 EN1.4301
4	Junta Gasket	RPTFE	RPTFE
5	Junta Eje Stem gasket	RPTFE	RPTFE
6	Junta O-Ring	FKM	FKM
7	Cuerpo Body	Acero al carbono Carbon Steel	ASTM A276 WCB
8	Alojamiento Packing	RPTFE	RPTFE
9	Presaestopa Packing gland	Acero inoxidable Stainless steel	ASTM A276 A304 EN1.4301
10	Muelle Mariposa Butterfly spring	Acero inoxidable Stainless steel	ASTM A276 A304 EN1.4301
11	Tuerca Eje Stem nut	Acero inoxidable Stainless steel	ASTM A276 A304 EN1.4301
12	Presaestopa Packing gland	Acero inoxidable Stainless steel	ASTM A276 A304 EN1.4301
13	Final Carrera Stop pin	Acero inoxidable Stainless steel	ASTM A276 A304 EN1.4301
14	Tuerca Nut	Acero inoxidable Stainless steel	ASTM A276 A304 EN1.4301
15	Maneta Handle	Acero inoxidable Stainless steel	ASTM A276 A304 EN1.4301
16	Cobertura maneta Handle sleeve	Plástico Plastic	PVC
17	Chaveta Pin	Acero inoxidable Stainless steel	ASTM A276 A304 EN1.4301
18	Eje Stem	Acero inoxidable Stainless steel	ASTM A276 A316 EN1.4401
19	Mecanismo antiestatico Antistatic device	Acero inoxidable Stainless steel	ASTM A276 A304 EN1.4301
20	Tuerca Nut	Acero inoxidable Stainless steel	ASTM A194 A304 EN1.4301
21	Tornillo Stud	Acero inoxidable Stainless steel	ASTM A193 A304 EN1.4301

5128

VÁLVULA ESFERA DOS PIEZAS INOXIDABLE BRIDA TWO PIECES BALL VALVE STAINLESS STEEL FLANGED END

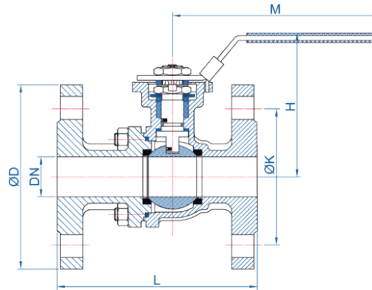

- **Cuerpo fabricado en acero inoxidable CF8M (AISI-316)**
Body made of stainless steel CF8M (AISI-316)
- **Bola fabricada en acero inoxidable CF8M (AISI-316)**
CF8M (AISI-316) stainless steel ball
- **Asientos de bola de PTFE reforzado con grafito**
Ball seats made of reinforced PTFE with graphite
- **Juntas en PTFE + grafito**
PTFE + graphite seat gaskets
- **Diseño S/ DIN 3202 con dispositivo de protección contra incendios**
Design according to DIN 3202 with fire safe system

- **Juntas tóricas eje FKM**
FKM stem O-rings
- **Bridas s/ UNE EN-1092-2 PN-16**
Flanges according to UNE EN-1092-2 PN-16
Presión máxima de trabajo: 16 Bar
Max. working pressure: 16 Bar
- **Temperatura de trabajo: -20°C / 180°C**
Working temperature: -20°C / 180°C
- **Paso total**
Full bore
- **Certificado ATEX**
ATEX certificate

DIMENSIONES / DIMENSIONS

CÓDIGO CODE	MEDIDA SIZE	DN	L	H	ØD	ØK	M	b	c	TORN BOLTS	€
5128-015*	1/2"	15	115	76	95	65	110	2	14	4xM14	107,42
5128-020*	3/4"	20	120	81	105	75	110	2	16	4xM14	125,08
5128-025*	1"	25	125	90	115	85	160	2	16	4xM14	154,56
5128-032*	1 1/4"	32	130	102	140	100	160	2	16	4xM18	238,97
5128-040*	1 1/2"	40	140	115	150	110	185	3	16	4xM18	261,15
5128-050**	2"	50	150	122	165	125	185	3	18	4xM18	360,22
5128-065**	2 1/2"	65	170	168	185	145	305	3	18	4xM18	556,00
5128-080**	3"	80	180	178	200	160	305	3	20	8xM18	702,69
5128-100**	4"	100	190	198	220	180	305	3	20	8xM18	1.002,33
5128-125**	5"	125	325	234	250	210	500	3	22	8xM18	2.117,20
5128-150**	6"	150	350	288	285	240	645	3	22	8xM22	2.896,81

PN-40*/16** (bridas flanges)

DIMENSIONES ISO 5211 FLANGE ISO 5211 DIMENSIONS

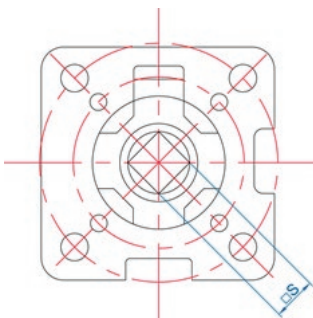

MEDIDA SIZE	DN	ISO 5211	S	TORQUE Nm
1/2"	15	F03-F04	9x9	4
3/4"	20	F03-F04	9x9	6,5
1"	25	F04-F05	11x11	8
1 1/4"	32	F04-F05	11x11	14
1 1/2"	38	F05-F07	14x14	20
2"	50	F05-F07	14x14	26
2 1/2"	65	F07-F10	17x17	45
3"	80	F07-F10	17x17	74
4"	100	F07-F10	19x19	103
5"	125	F10-F12	27x27	300
6"	150	F10-F12	27x27	400

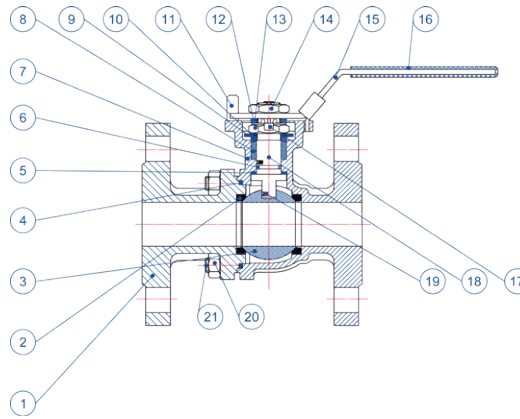

MATERIALES / MATERIALS

Nº	NOMBRE	MATERIALES	CALIDAD
Nº	NAME	MATERIALS	QUALITY
1	Tapa Bonnet	Acero inoxidable Stainless steel	ASTM A351 CF8M AISI 316 EN1.4408
2	Asiento bola Ball seat	CPTFE	PTFE + 15%Graphite
3	Bola Ball	Acero inoxidable Stainless steel	ASTM 276 AISI 316 EN1.4401
4	Junta Gasket	PTFE	PTFE
5	Junta eje Stem gasket	PTFE	PTFE
6	Junta tórica O-Ring	FKM	FKM
7	Cuerpo Body	Acero inoxidable Stainless steel	ASTM 351 CF8M AISI 316 EN1.4408
8	Cierre eje Stem seal	PTFE	PTFE
9	Prensaestopa Packing gland	Acero inoxidable Stainless steel	ASTM A276 AISI 304 EN1.4301
10	Arandela muelle Butterfly spring	Acero inoxidable Stainless steel	ASTM A276 AISI 304 EN1.4301
11	Tuerca eje Stem nut	Acero inoxidable Stainless steel	ASTM A276 AISI 304 EN1.4301
12	Prensaestopa Packing gland	Acero inoxidable Stainless steel	ASTM A276 AISI 304 EN1.4301
13	Final carrera Stop pin	Acero inoxidable Stainless steel	ASTM A276 AISI 304 EN1.4301
14	Tuerca Nut	Acero inoxidable Stainless steel	ASTM A276 AISI 304 EN1.4301
15	Maneta Handle	Acero inoxidable Stainless steel	ASTM A276 AISI 304 EN1.4301
16	Cobertura maneta Handle sleeve	Plástico Plastic	PVC
17	Mecanismo antiestático Antistatic device	Acero inoxidable Stainless steel	ASTM A276 AISI 304 EN1.4301
18	Eje Stem	Acero inoxidable Stainless steel	ASTM A276 AISI 316 EN1.4401
19	Arandela de empuje Thrust washer	Acero inoxidable Stainless steel	ASTM 276 AISI 304 EN1.4301
20	Tuerca Nut	Acero inoxidable Stainless steel	ASTM A194 AISI 304 EN1.4301
21	Tornillo Stud	Acero inoxidable Stainless steel	ASTM A193 AISI 304 EN1.4301

GRÁFICO PRESIÓN-TEMPERATURA / PRESSURE TEMPERATURE CHART

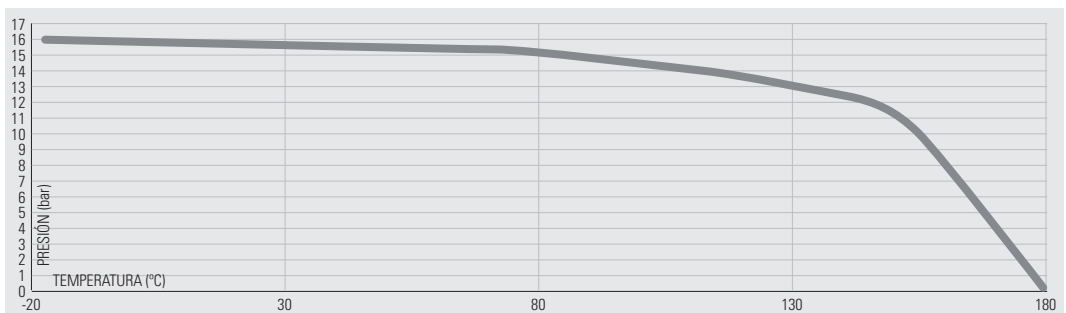

0913

FILTRO A-316 Y TAMIZ INOXIDABLE CONEXIÓN H-H
F-F STAINLESS STEEL A-316 Y STRAINER FILTER

INOX

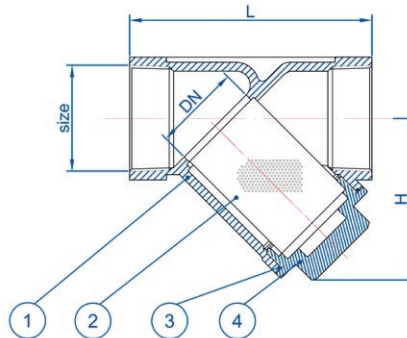
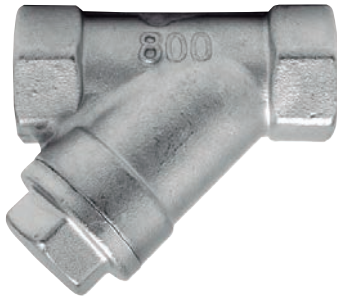

- Fabricado en inoxidable CF8M (AISI-316)
Made of stainless steel CF8M (AISI-316)
- Junta plana de PTFE
Flat PTFE gasket
- Grado de filtración: 1mm.
Filtration degree: 1mm.
- Roscas s/ norma ISO 7/1 (DIN 2999/BS 21)
F-F threads accordint to ISO 7/1 (DIN 2999/BS 21)
- Presión máxima de trabajo: 40 Bar (800 psi)
Max. working pressure: 40 Bar (800 psi)
- Temperatura de trabajo: -20°C / 180°C
Working temperature: -20°C / 180°C

DIMENSIONES / DIMENSIONS

CÓDIGO	MEDIDA	DN	L	H			€
CODE	SIZE	DN	L	H			€
0913-008	1/4"	11	65	58	70	35	12,83
0913-010	3/8"	11	65	58	70	35	13,10
0913-015	1/2"	12	65	58	40	20	13,10
0913-020	3/4"	17	78,5	68	40	20	17,91
0913-025	1"	22	89	88	24	12	29,93
0913-032	1 1/4"	32	105	100	20	10	34,55
0913-040	1 1/2"	38	120	108	12	6	47,30
0913-050	2"	48	140	130	6	1	70,16

MATERIALES / MATERIALS

Nº	NOMBRE	MATERIALES	CALIDAD
Nº	NAME	MATERIALS	QUALITY
1	Cuerpo Body	Acero inoxidable Stainless steel	CF8M
2	Tamiz Screen	Acero inoxidable Stainless steel	CF8M
3	Junta plana Flat gasket	PTFE	PTFE
4	Tapa Cap	Acero inoxidable Stainless steel	CF8M

COEFICIENTE KV / KV COEFFICIENT

MEDIDA	DN	Kv
SIZE	DN	Kv
1/4"	8	1,5
3/8"	10	3,0
1/2"	15	3,5
3/4"	20	6,5
1"	25	9,8
1 1/4"	32	15
1 1/2"	40	27
2"	50	35

0916

VÁLVULA RETENCIÓN DOS PIEZAS TWO PIECES SPRING VERTICAL CHECK VALVE

INOX

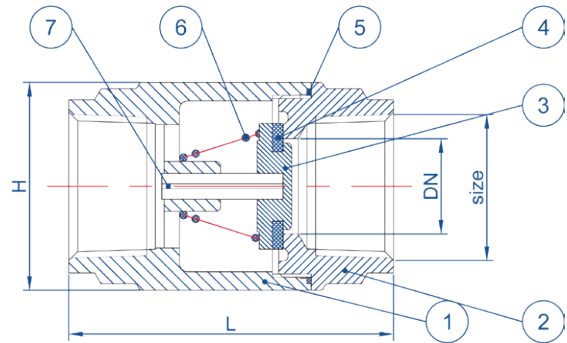

DIMENSIONES / DIMENSIONS

- **Cuerpo, tapa y disco fabricado en inoxidable CF8M (AISI-316)**
Body, cap and press cap made of stainless steel CF8M (AISI-316)
- **Junta cierre en PTFE**
Body packing made of PTFE
- **Asiento en PTFE**
PTFE seats
- **Roscas s/ norma ISO 228-1**
Thread ends according to ISO 228-1
- **Presión mínima de apertura: 0,5 Bar**
Minimum pressure to open: 0,5 Bar
- **Presión máxima de trabajo: 16 Bar (PN-16)**
Max. working pressure: 16 Bar (PN-16)
- **Temperatura de trabajo: -20° / 180°C**
Working temperature (Max): -20° / 180°C

CÓDIGO	MEDIDA	DN	L	H			€
CODE	SIZE	DN	L	H			€
0916-008	1/4"	11	54	30	100	50	18,14
0916-010	3/8"	11	54	30	100	50	18,14
0916-015	1/2"	12	57	34,5	70	35	19,66
0916-020	3/4"	17	64	41,5	54	27	24,80
0916-025	1"	22	75	48	34	17	32,14
0916-032	1 1/4"	32	82	61,5	20	10	46,50
0916-040	1 1/2"	38	93	71	20	10	63,28
0916-050	2"	48	100	87	12	6	85,82
0916-065	2 1/2"	60	120	107	10	5	150,54
0916-080	3"	71	140	121	2	1	222,00
0916-100	4"	90	150	152	1	1	354,72

MATERIALES / MATERIALS

Nº	NOMBRE	MATERIALES	CALIDAD
Nº	NAME	MATERIALS	QUALITY
1	Cuerpo Body	Acero inoxidable Stainless steel	CF8M – EN1.4408
2	Tapa Cap	Acero inoxidable Stainless steel	CF8M – EN1.4408
3	Disco Press cap	Acero inoxidable Stainless steel	A-316 – EN1.4401
4	Asiento Seat	PTFE	PTFE
5	Junta Cierre Body packing	PTFE	PTFE
6	Muelle Spring	Acero inoxidable Stainless steel	A-316 – EN1.4401
7	Eje Stem	Acero inoxidable Stainless steel	A-316 – EN1.4401

COEFICIENTE KV / KV COEFFICIENT

MEDIDA / SIZE	1/4"	3/8"	1/2"	3/4"	1"	1 1/4"	1 1/2"	2"	2 1/2"	3"	4"
DN	8	10	15	20	25	32	40	50	65	80	100
Kv	1,2	2,1	4	7,7	13,2	22,5	28,7	50,3	68,7	99,6	196,3

5118

VÁLVULA DE RETENCIÓN DISCO PN-40
DISC CHECK VALVE PN-40

INOX

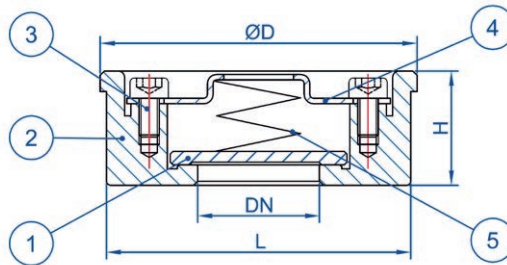

- Fabricada completamente en inoxidable CF8M (AISI-316)
Made completely of stainless steel CF8M (AISI-316)
- Bridas s/ norma DIN 2501 / EN-1092:1 PN-40
Flanges according to DIN 2501 / EN-1092:1 PN-40
- Cara a cara s/ norma DIN 3202-1999 K4
Face to face according to DIN 3202-1999 K4
- Presión máxima de trabajo: 40 Bar (PN-40)
Max. working pressure: 40 Bar (PN-40)
- Temperatura de trabajo: -20°C / 300°C
Working temperature: -20°C / 300°C
- Paso reducido
Reduced bore

DIMENSIONES / DIMENSIONS

CÓDIGO	MEDIDA	DN	L	H	ØD		€
CODE	SIZE	DN	L	H	ØD		€
5118-015	1/2"	15	43	16	53	1	10,53
5118-020	3/4"	20	53	19	63	1	13,30
5118-025	1"	25	63	22	73	1	19,71
5118-032	1 1/4"	30	75	28	84	1	29,34
5118-040	1 1/2"	38	86	31,5	94	1	36,66
5118-050	2"	47	95	40	107	1	55,44
5118-065	2 1/2"	62	115	46	126	1	85,24
5118-080	3"	77	131	50	144	1	106,79
5118-100	4"	95	151	60	164	1	172,75

MATERIALES / MATERIALS

Nº	NOMBRE	MATERIALES	CALIDAD
Nº	NAME	MATERIALS	QUALITY
1	Disco Disc	Acero inoxidable Stainless steel	AISI 316 CF8M
2	Cuerpo Body	Acero inoxidable Stainless steel	AISI 316 CF8M
3	Tornillo Bolt	Acero inoxidable Stainless steel	AISI 316
4	Tapa Cover	Acero inoxidable Stainless steel	AISI 316
5	Muelle Spring	Acero inoxidable Stainless steel	AISI 316

COEFICIENTE KV / KV COEFFICIENT

MEDIDA	DN	Kv
SIZE	DN	Kv
1/2"	15	4,6
3/4"	20	8,7
1"	25	12,1
1 1/4"	32	21
1 1/2"	40	28
2"	50	38,2
2 1/2"	65	54,1
3"	80	80,8
4"	100	94,3

PRESIÓN APERTURA / OPENING PRESSURE

CÓDIGO	MEDIDA	DN	CAUDAL VERTICAL ASCENDENTE	CAUDAL VERTICAL DESCENDENTE	CAUDAL HORIZONTAL
CODE	SIZE	DN	UP VERTICAL FLOW	DOWNWARD VERTICAL FLOW RATE	HORIZONTAL FLOW
5118-015	1/2"	15	0,030	0,025	0,025
5118-020	3/4"	20	0,030	0,025	0,025
5118-025	1"	25	0,030	0,025	0,025
5118-032	1 1/4"	30	0,035	0,025	0,025
5118-040	1 1/2"	38	0,035	0,025	0,030
5118-050	2"	47	0,035	0,025	0,030
5118-065	2 1/2"	62	0,035	0,025	0,030
5118-080	3"	77	0,040	0,025	0,030
5118-100	4"	95	0,040	0,025	0,035

GRÁFICO PRESIÓN-TEMPERATURA / PRESSURE TEMPERATURE CHART

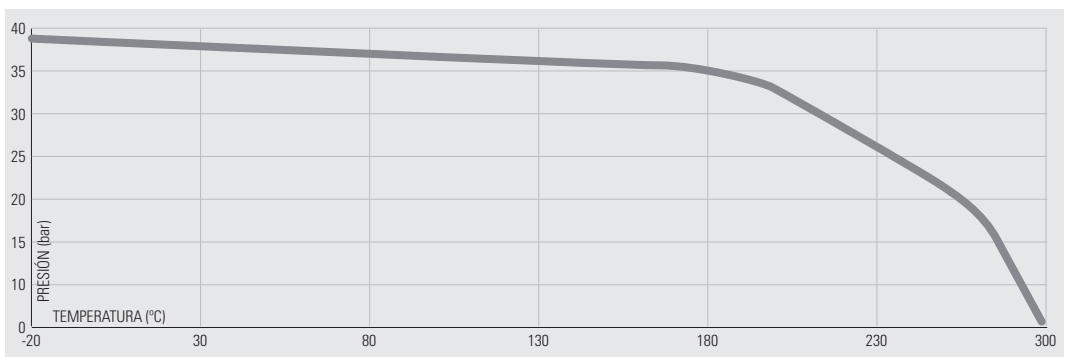

5119

VÁLVULA RETENCIÓN CLAPETA OSCILANTE TIPO WAFER THIN WAFER SWING CHECK VALVE

INOX

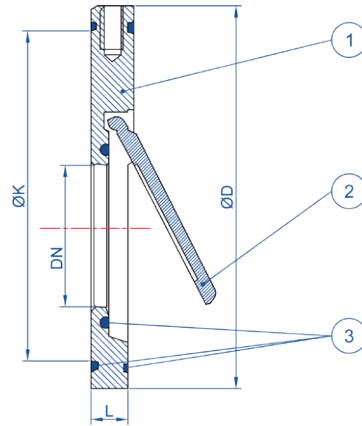

- **Cuerpo y disco inoxidable 316 (AISI-316)**
Body and disc made of stainless steel 316 (AISI-316)
- **Juntas de FKM**
FKM O-Rings
- **Bridas s/ norma EN-1092 PN-10/16 (DIN-2501/2502)**
Flanges according to EN-1092 PN-10/16 (DIN-2501/2502)

- **Presión máxima de trabajo: 16 Bar (PN-16)**
Max. working pressure: 16 Bar (PN-16)
- **Temperatura de trabajo: -20°C / 180°C**
Working temperature: -20°C / 180°C
- **Paso reducido**
Reduced bore

MATERIALES / MATERIALS

Nº	NOMBRE	MATERIALES	CALIDAD
Nº	NAME	MATERIALS	QUALITY
1	Cuerpo Body	Acero inox. S.S.	AISI 316 CF8M
2	Disco Disc	Acero inox. S.S.	AISI 316 CF8M
3	Juntas O-rings	FKM	FKM

DIMENSIONES / DIMENSIONS

CÓDIGO	MEDIDA	DN	L	ØD	ØK	[Diagram]		€
CODE	SIZE	DN	L	ØD	ØK	[Diagram]		€
5119-040	1 1/2"	22	14	92	87	1	1	50,89
5119-050	2"	32	14	107	99	1	1	52,74
5119-065	2 1/2"	40	14	127	113	1	1	66,80
5119-080	3"	54	14	142	129	1	1	86,82
5119-100	4"	70	18	162	150	1	1	116,79
5119-125	5"	92	18	192	172	1	1	157,27
5119-150	6"	114	20	218	197	1	1	206,34

GRÁFICO PRESIÓN-TEMPERATURA / PRESSURE TEMPERATURE CHART

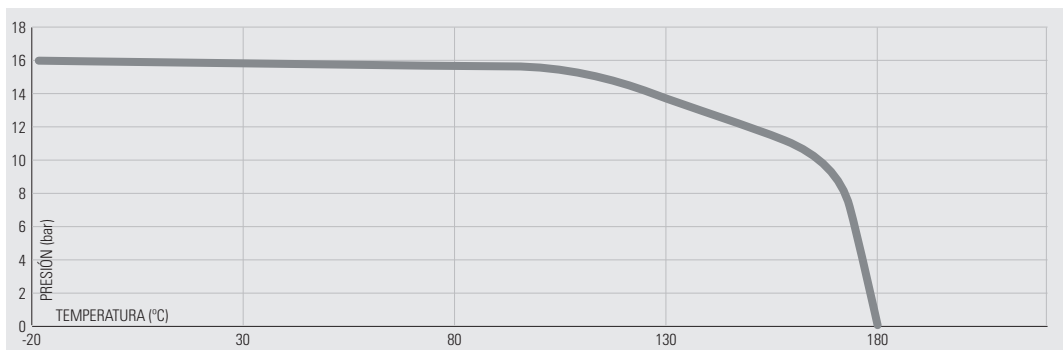



VÁLVULAS DE LATÓN

BRASS VALVES



PN40
VÁLVULA DE BOLA
BALL VALVE

ANTI CORROSIÓN **ANTIHIELO**
ANTI RUST **NO FROST**



- Paso total
- Sistema Antihielo
- Cuerpo reforzado
- Latón DZR CW602N
- Eje en acero inoxidable
- Nueva maneta ergonómica en acero inoxidable con tuerca autoblocante. Alta resistencia frente a la corrosión
- Juntas en FKM
- -20°C / 180°C
- Full bore
- Nofrost System
- Reinforced body
- DZR Brass CW602N
- Stainless steel stem
- New ergonomic stainless steel handle with self-locking nut. High protection from corrosion
- FKM o rings
- -20°C / 180°C



LEYENDA DE ICONOS
ICON KEY

Posibles codificaciones aplicadas en esta sección.

Possible encodings applied in this section.



CERTIFICADOS DE PRODUCTO
PRODUCT CERTIFICATES



Latón DZR DZR Brass Antihielo Nofrost system Código de barras EAN EAN bar code

PROPIEDADES DE PRODUCTO
PRODUCT PROPERTIES

4104

ACS

SINTEF

PLATINUM SERIES



VÁLVULA ESFERA PN-40 H-H PASO TOTAL EN LATÓN DZR PALANCA ERGONÓMICA COLOR NEGRO ACERO INOXIDABLE
F-F DZR BRASS BALL VALVE PN-40 FULL BORE WITH BLACK ERGONOMIC STAINLESS STEEL HANDLE

**ANTIHIELO
NOFROST**

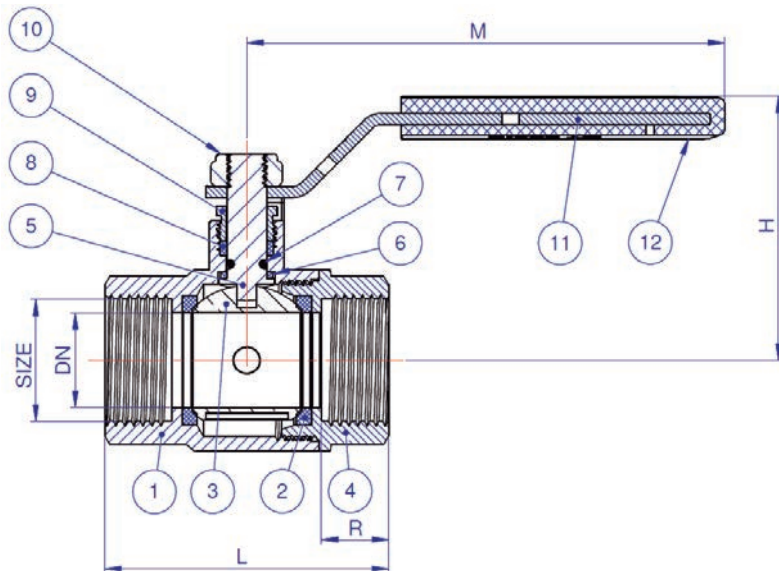

DZR



- Cuerpo y tapa en latón DZR
Body and nut in brass DZR
- Asientos PTFE y junta tórica FKM
PTFE seats and FKM O-ring
- Palanca en acero inoxidable con funda ergonómica
Stainless steel handle with ergonomic cover
- Sistema antihielo
No frost system

- Roscas s/ norma ISO 228/1 (DIN259)
Threads according to ISO 228/1 (DIN259)
- Temperatura de trabajo: -20°/180°C
Working temperature: -20°/180°C
- Presión de trabajo: 40 bar
Working pressure: 40 bar
- Apta para instalaciones energía solar
Suitable for solar energy installations

DIMENSIONES / DIMENSIONS

CODIGO CODE	MEDIDA SIZE			DN DN	L L	H H	M M	R R	€ €
4104-015	1/2"	48	12	15	57	49	93	15,0	Consultar
4104-020	3/4"	32	8	20	65	52	93	17,0	Consultar
4104-025	1"	20	5	25	77	61	115	18,5	Consultar
4104-032	1 1/4"	12	3	32	88	76	127	19,5	Consultar
4104-040	1 1/2"	12	2	40	105	83	155	23,5	Consultar
4104-050	2"	12	2	50	122	94	155	25,5	Consultar

MATERIALES / MATERIALS

Nº Nº	NOMBRE NAME	MATERIAL	CALIDAD QUALITY
1	Cuerpo Body	Latón Brass	CW602N
2	Asiento Seat	PTFE	PTFE
3	Bola Ball	1/2" - 1": Latón Brass	CW614N
3	Bola Ball	1 1/4" - 2": A.Inox S.S.	AISI 304
4	Tapa Bonnet	Latón Brass	CW602N
5	Eje Stem	Acero inoxidable Stainless steel	AISI 304
6	Junta eje Stem gasket	PTFE	PTFE
7	Junta tórica eje Stem o'ring	FKM	Shore 70
8	Empaquetadura eje Stem packing	PTFE	PTFE
9	Prensaestopa Packing gland	Latón Brass	CW614N
10	Tuerca autoblocante Selflocking nut	Acero inoxidable Stainless steel	AISI 304
11	Maneta Handle	Acero inoxidable Stainless steel	AISI 304
12	Cobertura maneta Plastic cover	Plástico Plastic	PVC

4204

ACS

SINTEF

PLATINUM SERIES





VÁLVULA ESFERA PN-40 H-H PASO TOTAL EN LATÓN DZR MANDO PALOMILLA COLOR NEGRO
F-F DZR BRASS BALL VALVE PN-40 FULL BORE WITH BLACK BUTTERFLY HANDLE

ANTIHIELO
NOFROST

DZR



DIMENSIONES / DIMENSIONS

CODIGO CODE	MEDIDA SIZE			€ €
4204-015	1/2"	60	15	Consultar
4204-020	3/4"	44	11	Consultar
4204-025	1"	28	7	Consultar

4504

ACS

SINTEF

PLATINUM SERIES

*

|||||

VÁLVULA ESFERA PN-40 M-H PASO TOTAL EN LATÓN DZR PALANCA ERGONÓMICA COLOR NEGRO ACERO INOXIDABLE
M-F DZR BRASS BALL VALVE PN-40 FULL BORE WITH BLACK ERGONOMIC STAINLESS STEEL HANDLE

ANTIHIELO
NOFROST

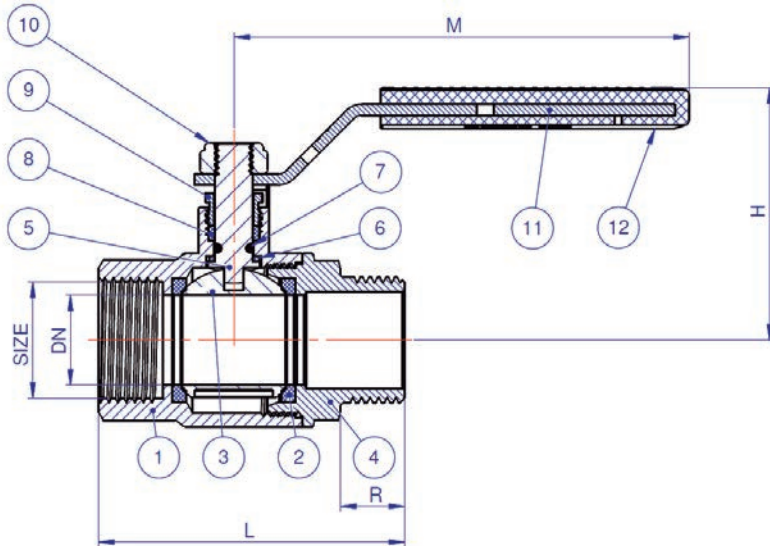

DZR



- Cuerpo y tapa en latón DZR
Body and nut in brass DZR
- Asientos PTFE y junta tórica FKM
PTFE seats and FKM O-ring
- Palanca en acero inoxidable con funda ergonómica
Stainless steel handle with ergonomic cover
- Sistema antihielo
No frost system

- Roscas s/ norma ISO 228/1 (DIN259)
Threads according to ISO 228/1 (DIN259)
- Temperatura de trabajo: -20°/180°C
Working temperature: -20°/180°C
- Presión de trabajo: 40 bar
Working pressure: 40 bar
- Apta para instalaciones energía solar
Suitable for solar energy installations

DIMENSIONES / DIMENSIONS

CODIGO CODE	MEDIDA SIZE			DN DN	L L	H H	M M	R R	€ €
4504-015	1/2"	40	10	15	65	49	83	15,0	Consultar
4504-020	3/4"	24	6	20	73	52	93	17,0	Consultar
4504-025	1"	16	4	25	85	61	115	18,5	Consultar
4504-032	1 1/4"	12	3	32	97	76	127	19,5	Consultar
4504-040	1 1/2"	12	2	40	114	83	155	23,5	Consultar
4504-050	2"	12	1	50	135	94	155	25,5	Consultar

MATERIALES / MATERIALS

Nº	NOMBRE	MATERIAL	CALIDAD
Nº	NAME	MATERIAL	QUALITY
1	Cuerpo Body	Latón Brass	CW602N
2	Asiento Seat	PTFE	PTFE
3	Bola Ball	1/2" - 1": Latón Brass	CW614N
3	Bola Ball	1 1/4" - 2": A.Inox S.S.	AISI 304
4	Tapa Bonnet	Latón Brass	CW602N
5	Eje Stem	Acero Inoxidable Stainless Steel	AISI 304
6	Junta eje Stem gasket	PTFE	PTFE
7	Junta tórica eje Stem o'ring	FKM	Shore 70
8	Empaquetadura eje Stem packing	PTFE	PTFE
9	Prensaestopa Packing gland	Latón Brass	CW614N
10	Tuerca autoblocante Selflocking nut	Acero Inoxidable Stainless Steel	AISI 304
11	Maneta Handle	Acero Inoxidable Stainless Steel	AISI 304
12	Cobertura maneta Plastic cover	Plástico Plastic	PVC

4604

ACS

SINTEF

PLATINUM SERIES





VÁLVULA ESFERA PN-40 M-H PASO TOTAL EN LATÓN DZR MANDO PALOMILLA COLOR NEGRO
M-F DZR BRASS BALL VALVE PN-40 FULL BORE WITH BLACK BUTTERFLY HANDLE

ANTIHIELO
NOFROST

DZR



DIMENSIONES / DIMENSIONS

CODIGO CODE	MEDIDA SIZE			€ €
4604-015	1/2"	60	15	Consultar
4604-020	3/4"	44	11	Consultar
4604-025	1"	28	7	Consultar

4113I

VÁLVULA DE COMPUERTA PASO TOTAL H-H PN-16
F-F GATE VALVE FULL BORE PN-16

ACS



- Uso en agua fría y agua caliente, químicos compatibles.
Used for cold and hot water, compatible chemicals.
- Temperatura máxima: 0/120°C
Max. Temperature: 0/120°C
- Presión de trabajo PN-16
Nominal Pressure PN-16

- Roscas según ISO 228/1 (DIN 259)
FF threads according to ISO 228/1 (DIN 259)
- Cierre metálico con junta FKM
Metallic wedge with FKM O'ring
- ACS de agua sanitaria
ACS for drinkable water

DIMENSIONES / DIMENSIONS

CODIGO CODE	MEDIDA SIZE	G (BSP) G (BSP)	ØD ØD	t t	L L	H H	h h	SW SW			€ €
4113-015I	1/2"	1/2"	15	9,5	38	79	68	26	48	12	Consultar
4113-020I	3/4"	3/4"	19	11,5	43	83	75	31	40	10	Consultar
4113-025I	1"	1"	24	12,5	48	96	87	38	24	6	Consultar
4113-032I	1 1/4"	1 1/4"	32	13	52	116	98	47	12	3	Consultar
4113-040I	1 1/2"	1 1/2"	39	15	57	125	115	53	8	2	Consultar
4113-050I	2"	2"	50	17	65	157	145	65	6	1	Consultar
4113-065I	2 1/2"	2 1/2"	60	16	66	202	156	82	4	1	Consultar
4113-080I	3"	3"	68	22	84	236	184	94	4	1	Consultar
4113-100I	4"	4"	93	17	85	296	227	123	4	1	Consultar

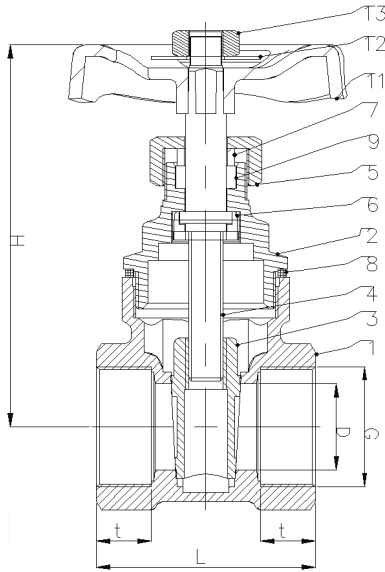

DN15 - DN25

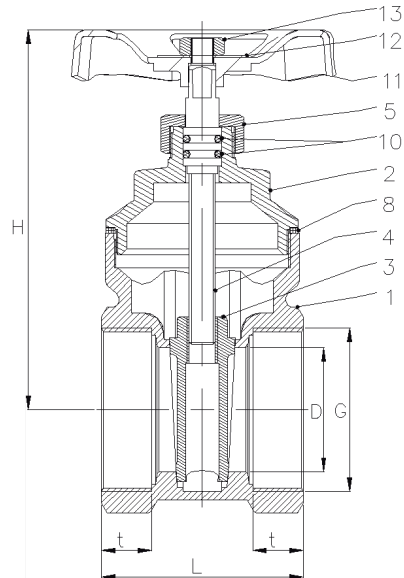

DN32 - DN100

MATERIALES / MATERIALS

Nº	NAME	MATERIAL	CALIDAD
Nº	NAME	MATERIAL	QUALITY
1	Cuerpo Body	Latón Brass	CW617N (CW614N en 4")
2	Tapa Bonnet	Latón Brass	CW617N (CW614N en 4")
3	Compuerta Wedge	Latón Brass	CW617N (CW614N en 4")
4	Eje Stem	Latón Brass	CW617N (CW614N en 4")
5	Tuerca cierra Packing nut	Latón Brass	CW617N (CW614N en 4")
6	Tuerca bloqueo Lock nut	Latón Brass	CW617N (CW614N en 4")
7	Anillo eje Stem ring	Latón Brass	CW614N
8	Arandela Washer	PTFE	PTFE
9	Cierre Eje Packing ring	PTFE	PTFE
10	Junta tórica O'Ring	FKM	FKM
11	Volante Hand wheel	Hierro Iron	-
12	Arandela Washer	Aluminio Aluminium	-
13	Tuerca Nut	Latón Brass	CW614N

4114

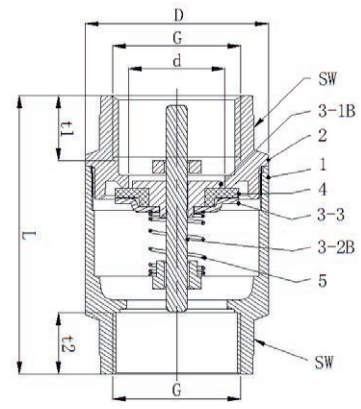

VÁLVULA DE RETENCIÓN PESADA CON OBTURADOR METÁLICO H-H
F-F NON RETURN VALVE HEAVY TYPE WITH METAL SHUTTER



- Uso en agua fría, agua caliente, aceites, gasóleos y químicos suaves. Agua con aditivos para instalaciones térmicas (Etilenglicol o Propilenglicol hasta el 40%)
Use of cold, hot water and air, oils and soft chemicals. Additives for water heating systems (Ethylene Glycol or Propylene Glycol to 40%)
- Presión máx. a 100°C: 10 bar
100°C Max Pressure: 10 bar
- Presión máx. a 60°C: 25 bar
60°C Max Pressure: 25 bar

- Temp. Mín: 0°C
Min. Temp: 0°C
- Roscas según ISO 228/1 (DIN 259)
Threads according to ISO 228/1 (DIN 259)
- UNE-EN-1717 Unidad de protección tipo EB válvula de retención anticontaminante no controlable
EN-1717 Protection unit type EB non return valve antipollution no controllable
- Latón según UNE-EN-12165
Brass according BS-EN-12165
- Certificación ACS
ACS Certified

DIMENSIONES / DIMENSIONS

CODIGO CODE	MEDIDA SIZE	PN	D	L	d	t1	t2	SW	PERFIL PERFIL			€ €
4114-015	1/2"	25	34,5	57	16	12	14	25	Hexa.	60	15	Consultar
4114-020	3/4"	25	42	64	22	14,5	14,5	31	Hexa.	48	12	Consultar
4114-025	1"	25	47,5	75	25	17,5	17,5	40	Hexa.	36	9	Consultar
4114-032	1 1/4"	16	60,5	83	32	16,5	18,5	50	Hexa.	24	6	Consultar
4114-040	1 1/2"	16	71	93	41	18,5	19	55	Hexa.	16	4	Consultar
4114-050	2"	16	87	100	50	21	21	67	Hexa.	18	3	Consultar
4114-065	2 1/2"	10	119	120	67	23	23	88	Octo.	6	1	Consultar
4114-080	3"	10	140	140	79	29	29	100	Octo.	4	1	Consultar
4114-100	4"	10	154	158	100	30	30	126	Octo.	3	1	Consultar

MATERIALES / MATERIALS

Nº	NAME	MATERIAL	CALIDAD QUALITY
1	Cuerpo Body	Latón Brass	CW617N
2	Tapa Bonnet	Latón Brass	CW617N
3-1B	Centro Core	Latón Brass	CW617N
3-2B	Eje Stem	Latón Brass	CW617N
3-3	Disco Disc	Acero Inoxidable Stainless Steel	A-316
4	Cierre Seal	NBR	NBR
5	Muelle Spring	Acero Inoxidable Stainless Steel	-

VÁLVULAS DE FUNDICIÓN

CASTING VALVES



VÁLVULAS DE FUNDICIÓN

CASTING VALVES

5110

FILTRO EN "Y" EMBRIDADO CON TAMIZ 1,8MM
FLANGED "Y" STRAINER WITH SIEVE 1,8MM

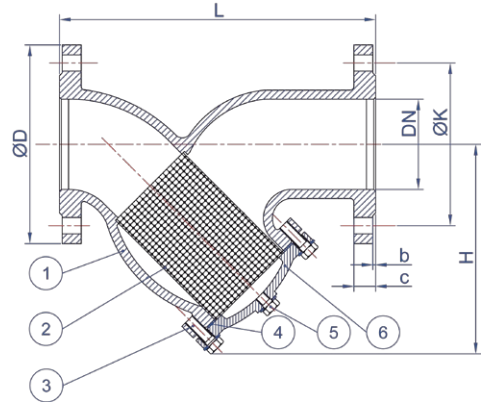

- Fabricado en fundición GG-25 (GJL-250)
Made of ductile iron GG-25 (GJL-250)
- Recubrimiento en pintura Epoxy RAL5013 (250µ)
Epoxy coating RAL5013 (250µ)
- Junta unión tapa EPDM
Cup joint EPDM
- Tamiz fabricado en acero inoxidable AISI 304
Internal sieve made of S.S. AISI 304
- Agujero tamiz 1,8mm (1.800 micras)
Hole sieve size 1,8mm (1.800 microns)

- Diseño s/ DIN 3202, EN 558-1
Design according to DIN 3202, EN 558-1
- Bridas s/ UNE EN1092-2
Flanges according to UNE EN1092-2
- Presión máxima de trabajo: 16 Bar (PN16)
Working pressure (Max): 16 Bar (PN16)
- Temperatura de trabajo: -10°C / 120°C
Working temperature: -10°C / 120°C

DIMENSIONES / DIMENSIONS

CÓDIGO	MEDIDA	DN	L	H	ØD	ØK	b	c	TORN	€
CODE	SIZE	DN	L	H	ØD	ØK	b	c	BOLTS	€
5110-040	1 1/2"	40	200	118	150	110	3	18	4xM16	46,28
5110-050	2"	50	230	178	165	125	3	20	4xM16	73,81
5110-065	2 1/2"	65	290	211	185	145	3	20	4xM16	105,72
5110-080	3"	80	310	202	200	160	3	22	8xM16	120,60
5110-100	4"	100	350	226	220	180	3	24	8xM16	158,24
5110-125	5"	125	400	264	250	210	3	26	8xM16	230,57
5110-150	6"	150	480	309	285	240	3	26	8xM20	320,69
5110-200	8"	200	600	410	340	295	3	30	12xM20	566,87
5110-250	10"	250	730	444	405	355	3	32	12xM24	969,84
5110-300	12"	300	850	486	460	410	4	32	12xM24	1.433,92
5110-350	14"	350	980	595	520	470	4	36	16xM24	2.365,42
5110-400	16"	400	1100	673	580	525	4	38	16xM27	4.109,41

MATERIALES / MATERIALS

Nº	NOMBRE	MATERIALES	CALIDAD
Nº	NAME	MATERIALS	QUALITY
1	Cuerpo Body	Hierro fundido Cast iron	EN-GJL-250 + Epoxy
2	Tamiz Sieve	Acero Inoxidable Stainless steel	AISI 304
3	Tornillos Screws	Acero Zincado Carbon steel zinc plated	ASTM A307
4	Junta Gasket	Caucho Rubber	EPDM
5	Tornillo purga Purge screw	Hierro fundido Cast iron	EN-GJL-250 + Epoxy
6	Tapa Cover	Hierro fundido Cast iron	EN-GJL-250 + Epoxy

DIMENSIONES TAPA / CAP SIZES

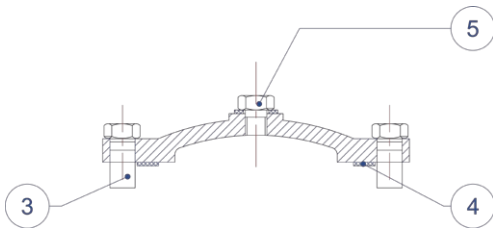

MEDIDA	DN	T.TAPA (3)	JUNTA (4)	T.PURGA (5)
SIZE	DN	COVER SCREWS	GASKET	PURGE SCREW
1 1/2"	40	4-M8x35	74x54	1/2"
2"	50	4-M10x40	86x66	1/2"
2 1/2"	65	4-M10x40	100x72	1/2"
3"	80	4-M12x40	123x90	1/2"
4"	100	4-M12x40	132x108	1/2"
5"	125	6-M12x45	160x135	1/2"
6"	150	6-M12x45	185x160	1/2"
8"	200	8-M12x50	240x210	3/4"
10"	250	12-M16x60	270x240	3/4"
12"	300	12-M16x60	315x280	3/4"
14"	350	16-M20x80	390x350	1"
16"	400	16-M20x80	460x420	1"

GRÁFICO PRESIÓN-TEMPERATURA / PRESSURE-TEMPERATURE CHART

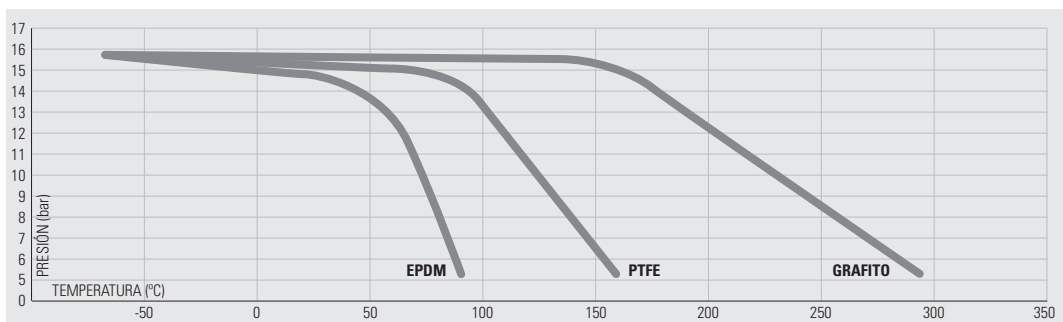

COEFICIENTE DE CAUDAL (KV) / FLOW FACTOR (KV)

MEDIDA	DN	Kv (1,8mm)	Kv (1mm)
SIZE	DN	Kv (1,8mm)	Kv (1mm)
1 1/2"	40	41	37
2"	50	65	61
2 1/2"	65	96	109
3"	80	149	138
4"	100	223	205
5"	125	347	308
6"	150	480	421
8"	200	853	759
10"	250	1104	994
12"	300	1450	1201
14"	350	1848	1567
16"	400	2315	2013

5116

VÁLVULA DE RETENCIÓN DOBLE DISCO INOXIDABLE STAINLESS STEEL DOUBLE DISC CHECK VALVE

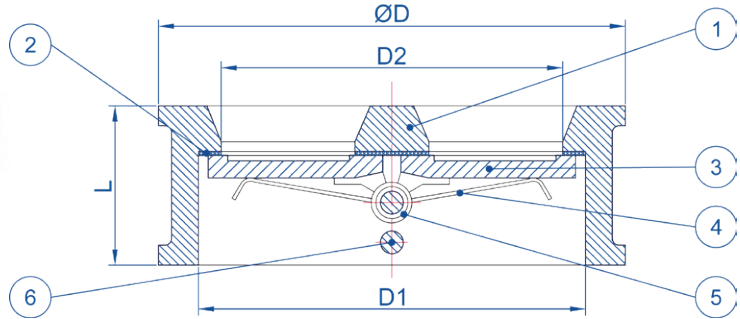

- Fabricado en fundición Nodular GGG-40 (GJS-400)
Made of ductile iron GGG-40 (GJS-400)
- Recubrimiento en pintura Epoxy RAL5013 (250µ)
Epoxy coating RAL5013 (250µ)
- Disco acero inoxidable AISI-304
Stainless steel disc AISI-304
- Asiento EPDM
EPDM seat gasket

- Bridas según UNE EN-1092-2 PN-10/PN-16
ANSI B16.5 Clase 125/150
Flanges according to UNE EN-1092-2 PN-10/PN-16
ANSI B16.5 Class 125/150
- Presión máxima de trabajo: 16 Bar (PN-16)
Working pressure (max): 16 Bar (PN-16)
- Temperatura de trabajo: -10°C / 80°C
Working temperature: -10°C / 80°C

DIMENSIONES / DIMENSIONS

CÓDIGO CODE	MEDIDA SIZE	DN	L	ØD ØD	D1	D2	€ €
5116-040	1 1/2"	40	54	92	60	46	29,99
5116-050	2"	50	54	102	64	46	39,19
5116-065	2 1/2"	65	54	121	78	60	44,67
5116-080	3"	80	57	134	94	70	59,00
5116-100	4"	100	64	162	117	84	73,14
5116-125	5"	125	70	192	145	115	97,81
5116-150	6"	150	76	218	170	134	142,65
5116-200	8"	200	95	273	224	184	236,46
5116-250	10"	250	108	328	265	220	344,35
5116-300	12"	300	143	378	310	260	453,17
5116-350	14"	350	184	438	360	302	1.410,30

MATERIALES / MATERIALS

Nº	NOMBRE NAME	MATERIALES MATERIALS	CALIDAD QUALITY
1	Cuerpo Body	Fundición dúctil Ductile iron	EN-GJS-400 (GGG40)
2	Asiento Seat	Caucho Rubber	EPDM
3	Disco Disc	Acero Inoxidable Stainless steel	AISI 304
4	Muelle Spring	Acero Inoxidable Stainless steel	AISI 304
5	Arandela Washer	Caucho Rubber	PTFE
6	Eje Stem	Acero Inoxidable Stainless steel	AISI 420

COEFICIENTE DE CAUDAL (KV)
FLOW FACTOR (KV)

MEDIDA	DN	Kv
SIZE	DN	KV
1 1/2"	40	15,3
2"	50	28
2 1/2"	65	60
3"	80	110
4"	100	170
5"	125	820
6"	150	1150
8"	200	1920
10"	250	2300
12"	300	3530
14"	350	5100

GRÁFICO PRESIÓN-TEMPERATURA / PRESSURE-TEMPERATURE CHART

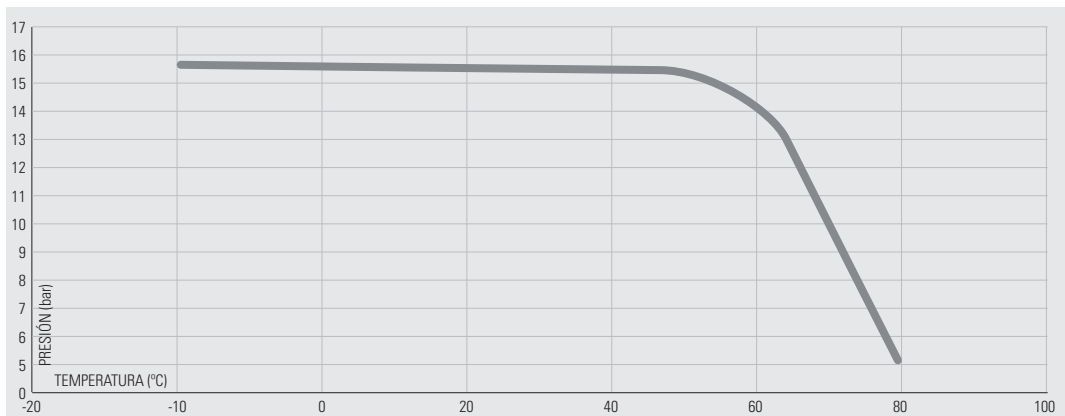

5125

VÁLVULA DE RETENCIÓN DE BOLA NBR CON BRIDAS BALL CHECK VALVE, NBR BALL, FLANGED END

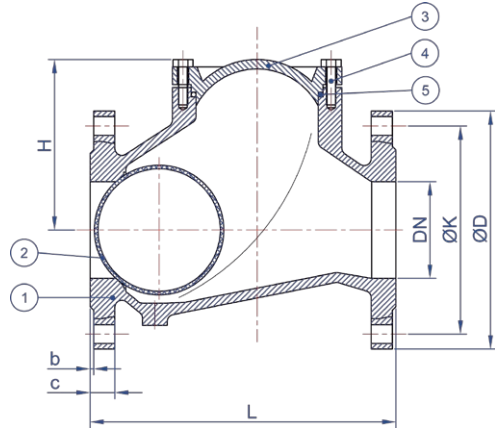

- Fabricado en fundición nodular GGG-40 (GJS-400)
Made of nodular ductile Iron GGG-40 (GJS-400)
- Recubrimiento en pintura Epoxy RAL5013 (250µ)
Epoxy coating RAL5013 (250µ)
- Bola metálica con recubrimiento elastómero NBR
Metal ball coated by NBR rubber
- Tornillería inoxidable AISI-304
Stainless steel bolts AISI-304

- Diseño s/ EN-12334, DIN 3202, EN 558-1
Design according to EN-12334, DIN 3202, EN 558-1
- Bridas s/ UNE EN1092-2
Flanges according to UNE EN1092-2
- Presión máxima de trabajo: 16 Bar (PN16)
Working pressure (Max): 16 Bar (PN16)
- Temperatura de trabajo: 0°C / 80°C
Working temperature (Max): 0° / 80°C
- Presión mínima de apertura 0'05 Bar
Minimum opening pressure 0'05 Bar

DIMENSIONES / DIMENSIONS

CÓDIGO	MEDIDA	DN	L	H	ØD	ØK	b	c	TORN	€
CODE	SIZE	DN	L	H	ØD	ØK	b	c	BOLTS	€
5125-040	1 1/2"	40	180	98	150	110	3	18	4xM16	97,84
5125-050	2"	50	200	106	165	125	3	20	4xM16	108,90
5125-065	2 1/2"	65	240	129	185	145	3	20	4xM16	133,84
5125-080	3"	80	260	146	200	160	3	22	8xM16	170,46
5125-100	4"	100	300	194	220	180	3	24	8xM16	225,92
5125-125	5"	125	350	207	250	210	3	26	8xM16	341,57
5125-150	6"	150	400	240	285	240	3	26	8xM20	454,53
5125-200	8"	200	500	322	340	295	3	30	12xM20	853,24
5125-250	10"	250	600	388	405	355	3	32	12xM24	1.570,66
5125-300	12"	300	700	408	460	410	4	32	16xM24	2.184,91
5125-350	14"	350	800	610	520	470	4	36	16xM24	3.259,70

MATERIALES / MATERIALS

Nº	NOMBRE	MATERIALES	CALIDAD
Nº	NAME	MATERIALS	QUALITY
1	Cuerpo Body	Fundición dúctil Ductile iron	EN-GJS-400 + Epoxy
2	Bola Ball	Acero + NBR Steel + NBR	EN-GJS-400 + NBR
3	Tapa Cover	Fundición dúctil Ductile iron	EN-GJS-400 + Epoxy
4	Tornillos Bolts	Acero Inoxidable Stainless steel	AISI 304
5	Junta Gasket	Caucho Rubber	NBR

COEFICIENTE DE CAUDAL (KV) / FLOW FACTOR (KV)

MEDIDA	DN	Kv
SIZE	DN	Kv
1 1/2"	40	90
2"	50	97
2 1/2"	65	176
3"	80	304
4"	100	617
5"	125	691
6"	150	1215
8"	200	3334
10"	250	4720
12"	300	6598
14"	350	6759

GRÁFICO PRESIÓN-TEMPERATURA / PRESSURE-TEMPERATURE CHART

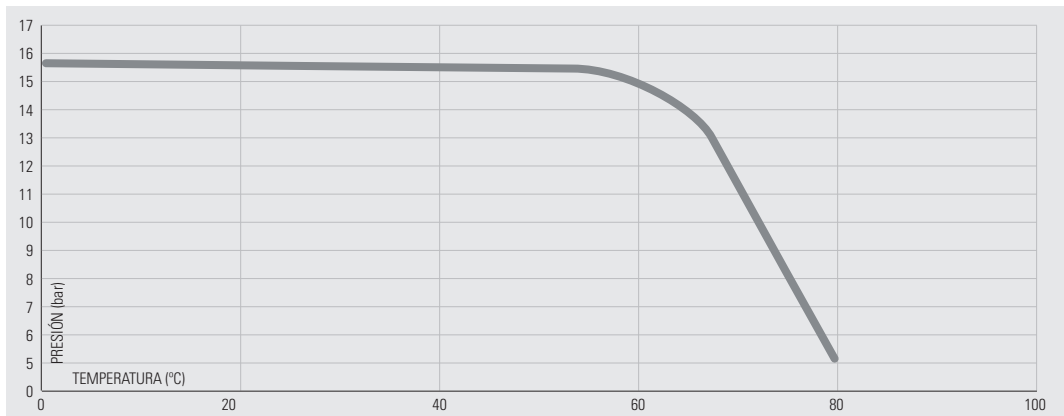

5142

VÁLVULA DE RETENCIÓN BOLA NBR ROSCADA
CHECK VALVE THREADED END NBR BALL

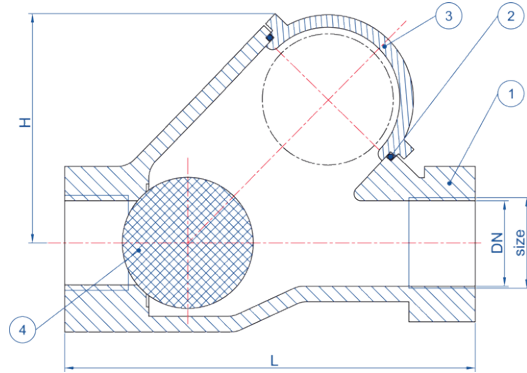

- Fabricado en fundición nodular EN-GJS-400
Made of ductile iron EN-GJS-400
- Recubrimiento en pintura Epoxy RAL5013 (250µ)
Epoxy coating RAL5013 (250µ)
- Bola de elastómero NBR
NBR rubber ball
- Fabricado bajo normativa: UNE-EN-12334
Manufactured according to standard UNE-EN-12334

- Roscas de conexión s/ norma ISO228
Connection threads according to standard ISO228
- Presión Máxima de trabajo: 10 Bar (PN10)
Working pressure (Max): 10 Bar (PN10)
- Temperatura de trabajo: 0°C / 80°C
Working temperature: 0°C / 80°C
- Presión mínima de apertura 0'01 Bar
Minimum opening pressure 0'01 Bar

DIMENSIONES / DIMENSIONS

CÓDIGO	MEDIDA	DN	L	H	C	TORN	€
CODE	SIZE	DN	L	H	C	BOLTS	€
5142-020	3/4"	20	125	74	40	2xM6	42,78
5142-025	1"	25	125	74	47	2xM6	43,99
5142-032	1 1/4"	32	132	74	59	2xM6	46,83
5142-040	1 1/2"	40	145	85	68	2xM6	57,77
5142-050	2"	50	174	116	82	2xM6	79,68

MATERIALES / MATERIALS

Nº	NOMBRE	MATERIALES	CALIDAD
Nº	NAME	MATERIALS	QUALITY
1	Cuerpo Body	Fundición nodular Ductile iron (epoxy coated)	EN-GJS-400 + Epoxy
2	Junta Gasket	NBR	NBR
3	Tapa Cover	Fundición nodular Ductile iron (epoxy coated)	EN-GJS-400 + Epoxy
4	Bola Ball	Metal + NBR	Metal + NBR

5113

VÁLVULA DE COMPUERTA CIERRE ELÁSTICO EPDM
EPDM RESILIENT WEDGE GATE VALVE, FLANGED ENDS



- Fabricado en fundición GGG-50 (GJS-500)
Made of ductile iron GGG-50 (GJS-500)
- Recubrimiento en pintura Epoxy RAL5013 (250µ)
Epoxy coating RAL5013 (250µ)
- Asiento elástico fundición + recubrimiento EPDM
Ductile iron wedge coated by EPDM rubber
- Accionamiento mediante volante o cuadrado
Actuated by handwheel or square nut
- Bidas S/UNE EN-1092-2 PN16
Flanges according to UNE EN-1092-2 PN16
- Presión máxima de trabajo: 16 Bar (PN16)
Working pressure (Max): 16 Bar (PN16)
- Temperatura de trabajo: -10°C / 120°C
Working temperature: -10°C / 120°C

DN40 - DN300

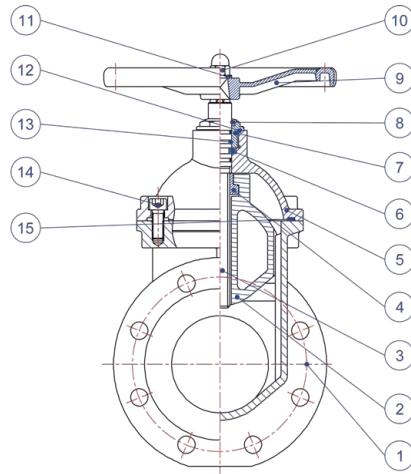
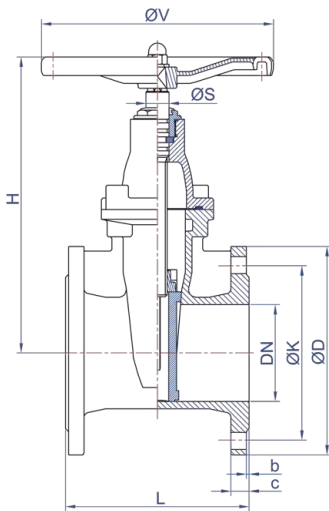

DN40 - DN300: DIMENSIONES / DIMENSIONS

CÓDIGO	MEDIDA	DN	L	H	ØK	ØD	ØV	ØS	B	C	TORN	€
CODE	SIZE	DN	L	H	ØK	ØD	ØV	ØS	B	C	BOLTS	€
5113-040	1 1/2"	50	150	255	110	165	180	18	3	19	4xM16	98,10
5113-050	2"	50	150	206,5	125	165	200	18	3	19	4xM16	107,05
5113-065	2 1/2"	65	170	232	145	185	200	18	3	19	4xM16	127,25
5113-080	3"	80	180	264	160	200	200	24	3	19	8xM16	158,45
5113-100	4"	100	190	320	180	220	240	24	3	19	8xM16	194,04
5113-125	5"	125	200	362	210	250	260	28	3	19	8xM16	284,42
5113-150	6"	150	210	408	240	285	280	28	3	19	8xM20	359,62
5113-200	8"	200	230	509	295	340	320	28	3	20	12xM20	558,03
5113-250	10"	250	250	599	355	405	360	32	3	22	12xM24	816,41
5113-300	12"	300	270	694	410	460	400	32	3	24,5	12xM24	1.221,27

- Bidas PN-10 / PN-16 de 5113-040 hasta 5113-150. Bidas PN-16 de 5113-200 hasta 5113-600
Flanges PN-10 / PN-16 from 5113-040 to 5113-150. Flanges PN-16 from 5113-200 to 5113-600

DN40 - DN300: MATERIALES / MATERIALS

Nº	NOMBRE	MATERIALES	CALIDAD
Nº	NAME	MATERIALS	QUALITY
1	Cuerpo Body	Fundición dúctil Ductile iron	EN-GJS-500 + Epoxy
2	Disco Disc	Fundición dúctil + EPDM Ductile iron + EPDM	EN-GJS-500 + EPDM
3	Tuerca eje Stem nut	Latón Brass	CW604N
4	Eje Stem	Acero inoxidable Stainless steel	UNE 2Cr13
5	Tapa Bonnet	Fundición dúctil Ductile iron	EN-GJS-500 + Epoxy
6	Chaveta eje Stem half ring	Latón Brass	CW604N
7	Prensaestopa Gland	Latón Brass	CW604N
8	Guardapolvo Dusty cap	Caucho Rubber	NBR
9	Volante Handwheel	Fundición dúctil Ductile iron	EN-GJS-500
10	Tuerca Nut	Acero al carbono Carbon steel	A 8.8
11	Arandela Washer	Acero al carbono Carbon steel	A 8.8
12	Junta tórica O-Ring	Caucho Rubber	NBR
13	Junta tórica O-Ring	Caucho Rubber	NBR
14	Tornillo Bolt	Acero al carbono Carbon steel	A 8.8
15	Junta tapa Bonnet gasket	Caucho Rubber	NBR

DN350 - DN600

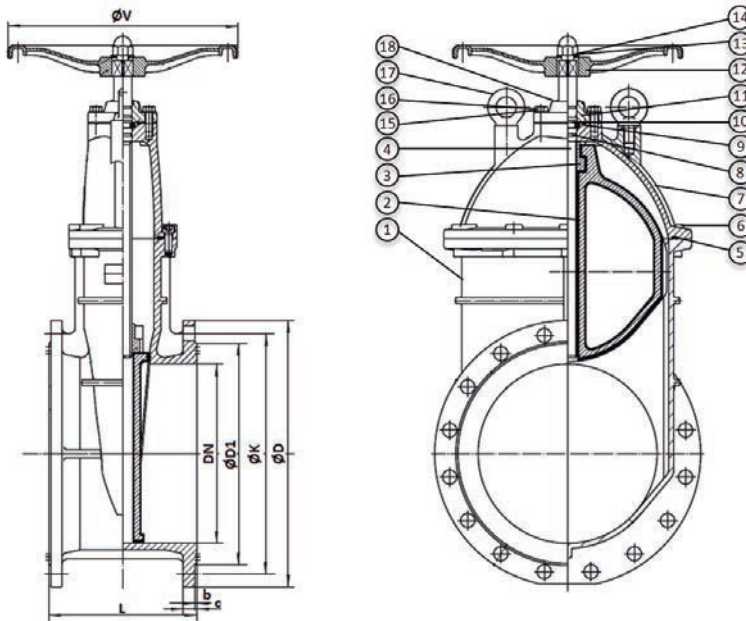

DN350 - DN600: DIMENSIONES / DIMENSIONS

CÓDIGO	MEDIDA	DN	L	ØK	ØD	ØV	B	C	TORN	€
CODE	SIZE	DN	L	ØK	ØD	ØV	B	C	BOLTS	€
5113-350	14"	350	290	470	520	450	4	26,5	16xM24	2.385,41
5113-400	16"	400	310	525	580	500	4	28	16xM27	2.937,92
5113-500	20"	500	350	650	715	600	4	31,5	20xM30	5.828,84
5113-600	14"	600	390	770	840	700	5	36	20xM33	7.837,98

DN350 - DN600: MATERIALES / MATERIALS

Nº	NOMBRE	MATERIALES	CALIDAD
Nº	NAME	MATERIALS	QUALITY
1	Cuerpo Body	Fundición dúctil Ductile iron	EN-GJS-500 + Epoxy
2	Disco Disc	Fundición dúctil + EPDM Ductile iron + EPDM	EN-GJS-500 + EPDM
3	Tuerca eje Stem nut	Latón Brass	CW604N
4	Eje Stem	Acero inoxidable Stainless steel	420
5	Junta tapa Bonnet gasket	Caucho Rubber	EPDM
6	Tornillo Bolt	Acero al carbono Carbon Steel	A 8.8
7	Tapa Bonnet	Fundición dúctil Ductile iron	EN-GJS-500 + Epoxy
8	Junta tórica O-Ring	Caucho Rubber	EPDM
9	Junta tórica O-Ring	Caucho Rubber	EPDM
10	Chaveta eje Stem half ring	Latón Brass	CW604N
11	Tapa Bonnet	Fundición dúctil Ductile iron	EN-GJS-500 + Epoxy
12	Volante Handwheel	Fundición dúctil Ductile iron	EN-GJS-500
13	Arandela plana Flat washer	Acero al carbono Carbon Steel	A 8.8
14	Tuerca Nut	Acero al carbono Carbon Steel	ASTM A36
15	Tornillo Bolt	Acero inoxidable Stainless steel	304
16	Arandela plana Flat washer	Acero al carbono Carbon Steel	ASTM A36
17	Tornillo Bolt	Acero al carbono Carbon Steel	A 8.8
18	Guardapolvo Dust cover	Caucho Rubber	NBR

MEDIDAS EJE / STEM DIMENSIONS

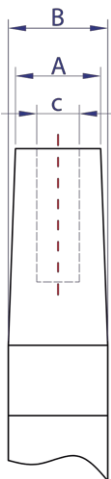

MEDIDA	A	B	C
SIZE	A	B	C
DN40	13	16,5	M8
DN50	13	16,5	M8
DN65	13	16,5	M8
DN80	13	16,5	M8
DN100	16	20,5	M8
DN125	17	21,5	M8
DN150	20	25,5	M10
DN200	20	25,5	M10
DN250	21	27	M10
DN300	24	30,5	M10
DN350	26	30,5	M10
DN400	33	-	-
DN500	34	-	-
DN600	41	-	-

MEDIDAS VOLANTE / WHEEL DIMENSIONS

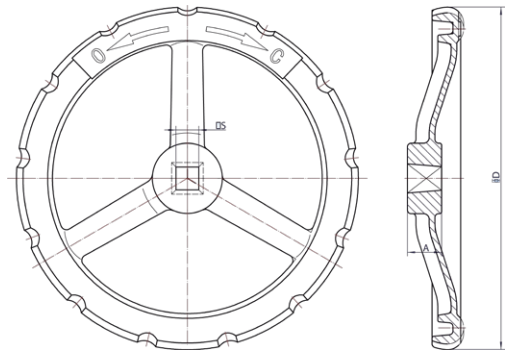

MEDIDA	ØD	□ S
SIZE	ØD	□ S
DN50	180	13x13
DN65-80	200	13x13
DN100	240	16x16
DN125	260	17x17
DN150	280	20x20
DN200	320	20x20
DN250	360	21,5x21,5
DN300	400	24x24
DN350	450	30x30
DN400	500	33x33
DN500	600	34,5x34,5
DN600	700	41,5x41,5

COEFICIENTE DE CAUDAL (KV) / FLOW FACTOR (KV)

MEDIDA	DN	Kv
SIZE	DN	Kv
1 1/2"	40	93
2"	50	202
2 1/2"	65	338
3"	80	547
4"	100	842
5"	125	1.253
6"	150	2.248
8"	200	4.056
10"	250	5.995
12"	300	9.003
14"	350	10.777
16"	400	15.705
20"	500	23.309
24"	600	35.805

GRÁFICO PRESIÓN-TEMPERATURA / PRESSURE-TEMPERATURE CHART

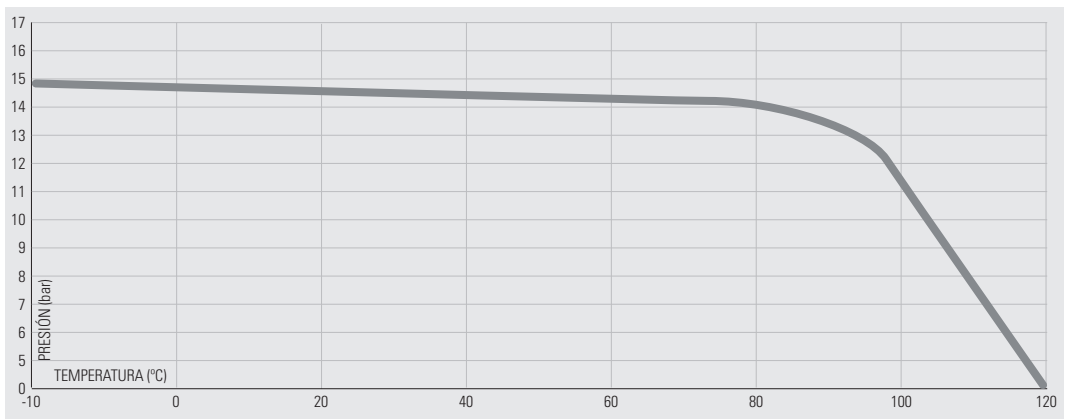

5146

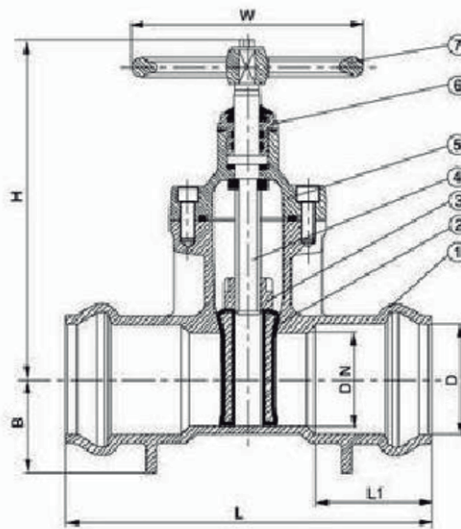
VÁLVULA DE COMPUERTA EPDM TERMINACIÓN PARA PVC
EPDM RESILIENT WEDGE GATE PVC PIPESNUEVO
NEW

- Cuerpo en fundición dúctil EN GJS-400
Body in Ductile iron EN GJS-400
- Eje en acero inoxidable AISI 420
Stem in stainless steel AISI 420
- Recubrimiento Epoxy
Coating: Fusion bonded Epoxy

- Compuerta en EPDM
Wedge in rubber EPDM
- Presión máxima de trabajo: 16 Bar (PN-16)
Working pressure (max): 16 Bar (PN-16)
- Temperatura de trabajo: -10°C / 120°C
Working temperature: -10°C / 120°C

DIMENSIONES / DIMENSIONS

CÓDIGO	MEDIDA	DN	L	L1	H	B	W	€
CODE	SIZE (D)	DN	L	L1	H	B	W	€
5146-110	110	100	355	108	335	92	255	234,97
5146-125	125	125	375	110	390	105	305	355,00
5146-140	140	125	375	122	400	105	305	355,00
5146-160	160	150	405	136	440	115	308	415,25

MATERIALES / MATERIALS

Nº	NOMBRE	MATERIALES	CALIDAD
Nº	NAME	MATERIALS	QUALITY
1	Cuerpo Body	Fundición dúctil Ductile iron	EN-GJS-400
2	Compuerta Wedge	Fundición dúctil Ductile iron	EN-GJS-400 EPDM
3	Tuerca eje Stem nut	Latón Brass	-
4	Eje Stem	Acero inoxidable Stainless steel	AISI 420
5	Tapa Bonnet	Fundición dúctil Ductile iron	EN-GJS-400
6	Prensa estopa Gland	Latón Brass	-
7	Volante Handwheel	Fundición dúctil Ductile iron	EN-GJS-400

5143

VÁLVULA DE COMPUERTA CIERRE ELÁSTICO EPDM EXTREMOS ROSCADOS
EPDM RESILIENT WEDGE GATE VALVE, THREADED ENDS

WRAS

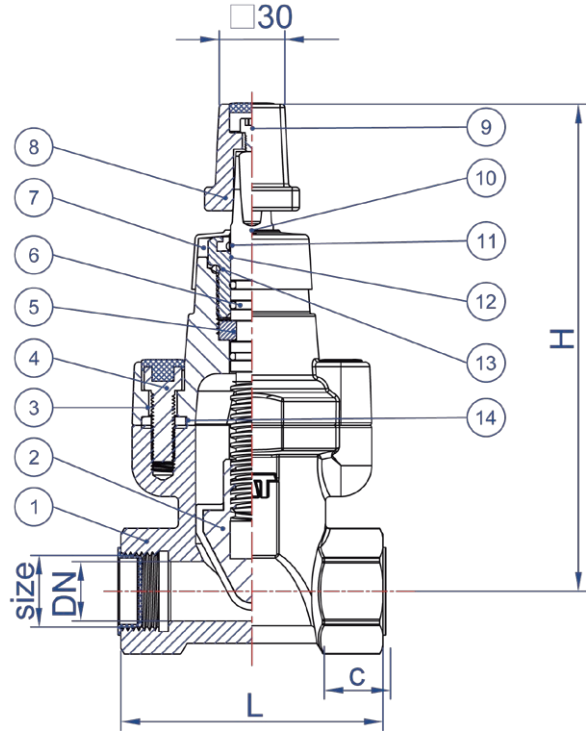

- Fabricado en fundición GGG-50 (GJS-500)
Made of ductile iron GGG-50 (GJS-500)
- Recubrimiento en pintura Epoxy RAL5013 (250µ)
Epoxy coating RAL5013 (250µ)
- Diseño según EN-12334
Design according to EN-12334
- Asiento elástico fundición con recubrimiento elastómero EPDM
Ductile iron wedge coated by EPDM rubber

- Accionamiento mediante volante o cuadrado (□30mm)
Actuated by handwheel or square nut (□30mm)
- Presión máxima de trabajo: 16 Bar (PN-16)
Working pressure (max): 16 Bar (PN-16)
- Temperatura de trabajo: -10°C / 120°C
Working temperature: -10°C / 120°C

DIMENSIONES / DIMENSIONS

CÓDIGO	MEDIDA	DN	L	H	C	€
CODE	SIZE	DN	L	H	C	€
5143-020	3/4"	20	110	198	32	80,29
5143-025	1"	25	110	198	32	84,24
5143-032	1 1/4"	32	120	202	32	92,09
5143-040	1 1/2"	40	124	210	30	103,89
5143-050	2"	50	140	228	30	116,48

MATERIALES / MATERIALS

Nº	NOMBRE	MATERIALES	CALIDAD
Nº	NAME	MATERIALS	QUALITY
1	Cuerpo Body	Fundición dúctil Ductile iron	EN-GJS-500 + Epoxy
2	Compuerta Wedge	Fundición dúctil + EPDM Ductile iron + EPDM	EN-GJS-500 + EPDM
3	Tapa Bonnet	Fundición dúctil Ductile iron	EN-GJS-500 + Epoxy
4	Tornillo Bolt	Fundición acero Alloy steel	UNE 34CrMo4
5	Anillo posicionamiento Location ring	Latón Brass	CW617N
6	Junta tórica O-Ring	Caucho Rubber	NBR
7	Guardapolvo Rubber gland	Caucho Rubber	EPDM
8	Cuadrado Square handle	Hierro fundido Cast iron	EN-GJL-250
9	Tornillo Bolt	Acero inoxidable Stainless steel	A2-70
10	Eje Stem	Acero inoxidable Stainless steel	A420
11	Cubierta Lining bush	Caucho Rubber	EPDM
12	Tuerca cierre Sealing nut	Latón Brass	CW604N
13	Junta tórica O-Ring	Caucho Rubber	NBR
14	Junta Gasket	Caucho Rubber	EPDM

COEFICIENTE DE CAUDAL (KV) / FLOW FACTOR (KV)

MEDIDA	DN	Kv
SIZE	DN	Kv
3/4"	20	20
1"	25	34
1 1/4"	32	60
1 1/2"	40	100
2"	50	190

GRÁFICO PRESIÓN-TEMPERATURA / PRESSURE-TEMPERATURE CHART

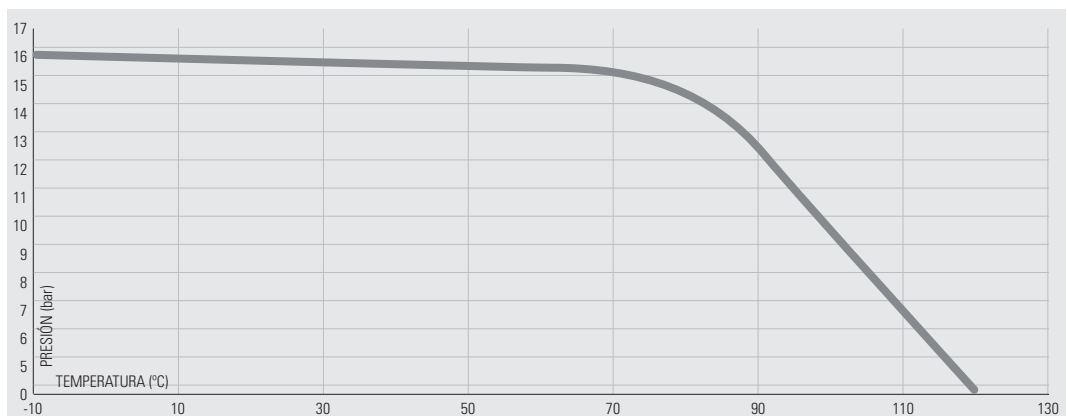

5130

VÁLVULA DE GLOBO EN ACERO AL CARBONO CON FUELLE EMBRIDADA PN-40
CAST STEEL BELLOW GLOBE VALVE FLANGED ENDS PN-40

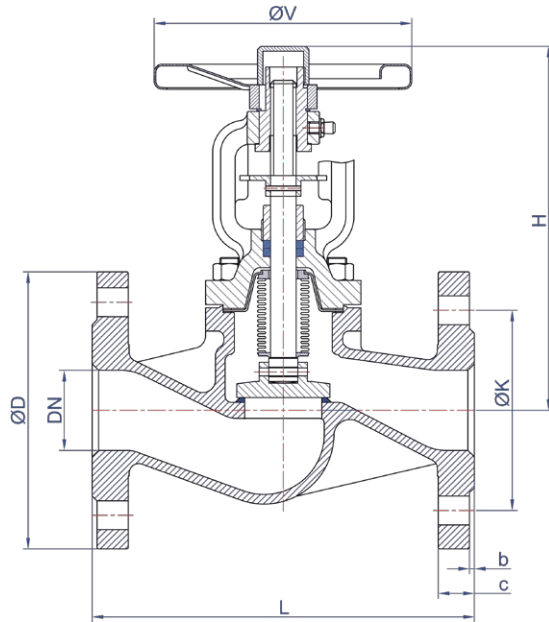

- Fabricado en acero al carbono GS-C25
Made of carbon steel casting GS-C25
- Asiento en acero inoxidable 2Cr13 Stelite
Stainless steel seat 2Cr13 Stelite
- Fuelle INOX AISI-304 y juntas de grafito
Bellow in S.S. AISI-304 and graphite gaskets

- Fabricado bajo normativa:
DIN 3356-82, EN-1092-2 PN40, DIN3202 F1
Manufactured according to standards:
DIN 3356-82, En-1092-2 PN40, DIN3202 F1
- Presión Máxima de trabajo: 40 Bar (PN40)
Working pressure (Max): 40 Bar (PN40)
- Temperatura de trabajo: -10°C / 400°C
Working temperature: -10°C / 400°C

DIMENSIONES / DIMENSIONS

CÓDIGO	MEDIDA	DN	L	H	ØK	ØD	b	c	ØV	TORN	€
CODE	SIZE	DN	L	H	ØK	ØD	b	c	ØV	BOLTS	€
5130-015	1/2"	15	130	180	65	95	2	16	120	4xM12	141,53
5130-020	3/4"	20	150	190	75	105	2	18	140	4xM12	152,80
5130-025	1"	25	160	220	85	115	2	18	140	4xM12	160,32
5130-032	1 1/4"	32	180	222	100	140	2	18	140	4xM16	194,74
5130-040	1 1/2"	40	200	252	110	150	2	18	160	4xM16	225,42
5130-050	2"	50	230	263	125	165	2	20	160	4xM16	259,88
5130-065	2 1/2"	65	290	295	145	185	2	22	180	8xM16	358,81
5130-080	3"	80	310	330	160	200	2	24	200	8xM16	489,06
5130-100	4"	100	350	350	190	235	2	26	250	8xM20	710,73
5130-125	5"	125	400	420	220	270	2	26	250	8xM24	1.069,55
5130-150	6"	150	480	455	250	300	2	28	350	8xM24	1.413,33
5130-200	8"	200	600	550	320	375	3	34	450	12xM27	2.521,08

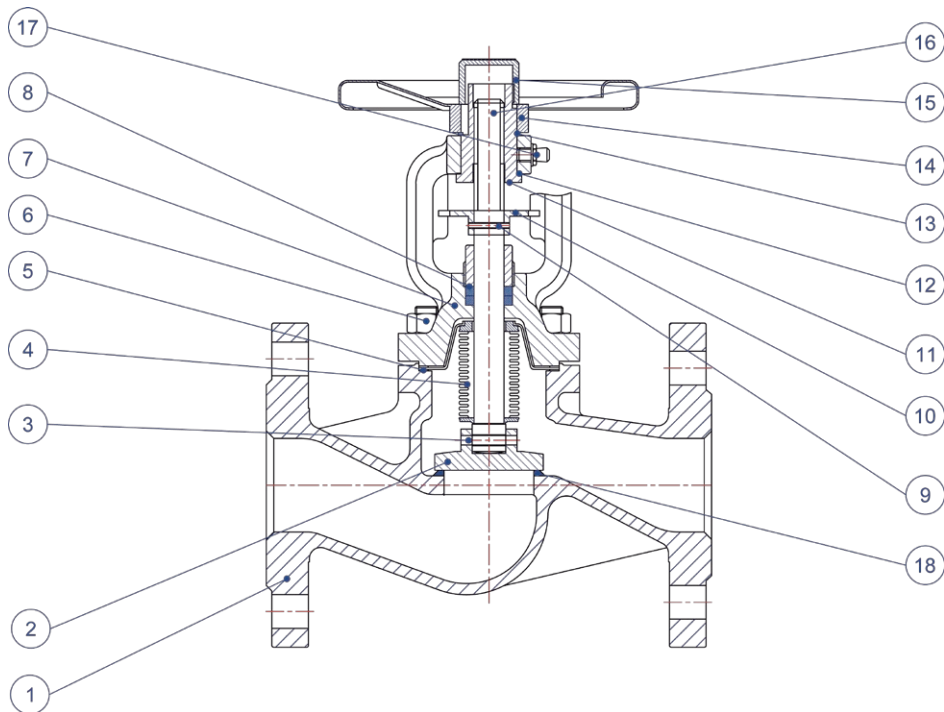

MATERIALES / MATERIALS

Nº	NOMBRE	MATERIALES	CALIDAD
Nº	NAME	MATERIALS	QUALITY
1	Cuerpo Body	Acero al carbono Carbon steel	GS-C25
2	Disco Disc	Acero al carbono Carbon steel	C.S. 13Cr
3	Pasador Pin	Acero inoxidable Stainless steel	AISI 304
4	Fuelle Bellows	Acero inoxidable Stainless steel	AISI 304
5	Junta Gasket	INOX. + Grafito S.S. + Graphite	AISI 304 + Graphite
6	Tornillo Bolt	Acero al carbono Carbon steel	ASTM A193 B7
	Tuerca Nut	Acero al carbono Carbon steel	ASTM A194 2H
7	Tapa Cover	Acero al carbono Carbon steel	GS-C25
8	Prensaestopa Packing gland	Acero al carbono + grafito Carbon steel + graphite	AISI 105 + Graphite
9	Pasador Pin	Acero al carbono Carbon steel	AISI 105
10	Pieza guía Guide piece	Acero al carbono Carbon steel	AISI 105
11	Chaveta Pin	Acero al carbono Carbon steel	CK-25
12	Arandela Washer	Acero inoxidable Stainless steel	AISI 304
13	Anillo de seguridad Circlip	Acero para muelles Spring steel	65Mn
14	Tuerca fijación Lock nut	Acero al carbono Carbon steel	AISI 105
15	Volante Hand wheel	Acero al carbono Carbon steel	AISI 105
16	Eje Stem	Acero inoxidable Stainless steel	X2013Cr
17	Tobera Nozzle	Acero inoxidable Stainless steel	AISI 304
18	Asiento Seat	Acero inoxidable Stainless steel	13Cr

COEFICIENTE DE CAUDAL (KV) / FLOW FACTOR (KV)

MEDIDA / SIZE	1/2"	3/4"	1"	1 1/4"	1 1/2"	2"	2 1/2"	3"	4"	5"	6"	8"	10"
DN	15	20	25	32	40	50	65	80	100	125	150	200	250
Kv	4,2	7,4	12	19	30	47	77	120	188	288	410	725	1145

GRÁFICO PRESIÓN-TEMPERATURA / PRESSURE-TEMPERATURE CHART

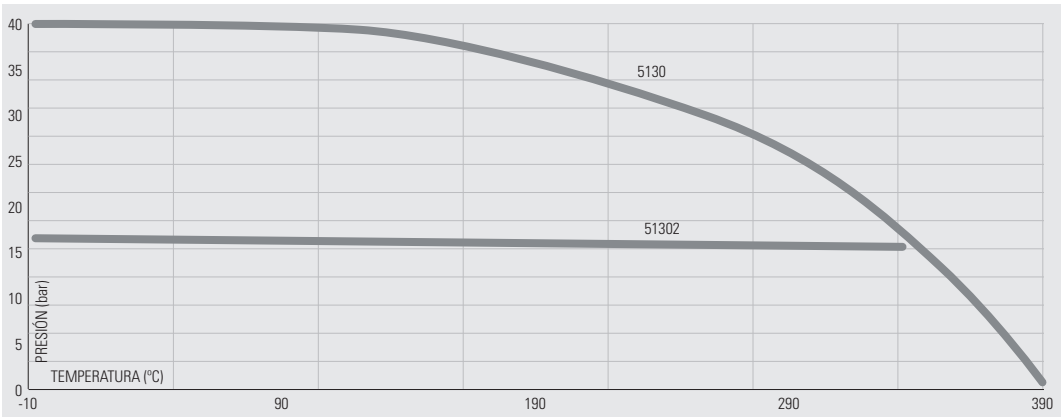

51302

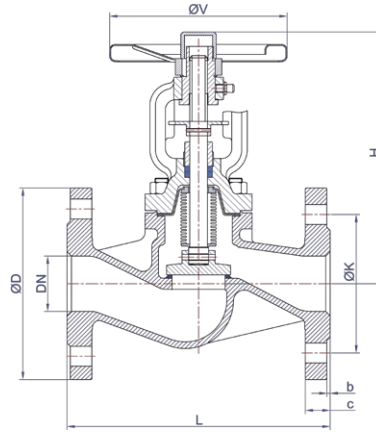
VÁLVULA DE GLOBO EN ACERO AL CARBONO CON FUELLE EMBRIDADA PN-16
CAST STEEL BELLOW GLOBE VALVE FLANGED ENDS PN-16

- Fabricado en acero al carbono GS-C25
Made of carbon steel casting GS-C25
- Asiento en acero inoxidable 2Cr13 Stelitel
Stainless steel seat 2Cr13 Stelitel
- Fuelle en acero inoxidable AISI-304 y juntas de grafito
Bellow in stainless steel. AISI-304 and graphite gaskets

- Fabricado bajo normativa:
DIN 3356-82, EN-1092-2 PN16, DIN3202 F1
Manufactured according to standards:
DIN 3356-82, En-1092-2 PN16, DIN3202 F1
- Presión Máxima de trabajo: 16 Bar (PN16)
Working pressure (Max): 16 Bar (PN16)
- Temperatura de trabajo: -10°C / 400°C
Working temperature: -10°C / 400°C

DIMENSIONES / DIMENSIONS

CÓDIGO	MEDIDA	DN	L	H	ØK	ØD	b	c	ØV	TORN	€
CODE	SIZE	DN	L	H	ØK	ØD	b	c	ØV	BOLTS	€
51302-015	1/2"	15	130	180	65	95	2	16	120	4xM12	137,76
51302-020	3/4"	20	150	190	75	105	2	18	140	4xM12	149,05
51302-025	1"	25	160	220	85	115	2	18	140	4xM12	156,57
51302-032	1 1/4"	32	180	220	100	140	2	18	140	4xM16	190,97
51302-040	1 1/2"	40	200	255	110	150	2	18	160	4xM16	221,67
51302-050	2"	50	230	260	125	165	2	20	160	4xM16	256,12
51302-065	2 1/2"	65	290	295	145	185	2	18	180	8xM16	343,78
51302-080	3"	80	310	330	160	200	2	20	200	8xM16	458,38
51302-100	4"	100	350	350	180	220	2	20	250	8xM16	660,62
51302-125	5"	125	400	420	210	250	2	22	250	8xM16	901,74
51302-150	6"	150	480	455	240	285	2	22	350	8xM20	1.329,42
51302-200	8"	200	600	550	295	340	3	24	500	12xM20	2.139,09
51302-250	10"	250	730	730	355	405	3	26	500	12xM24	4.049,00

GRÁFICO PRESIÓN-TEMPERATURA
PRESSURE-TEMPERATURE CHART

Consultar tabla de 5130. Pag. 84 / See table of 5130. Page 84

COEFICIENTE DE CAUDAL (KV)
FLOW FACTOR (KV)

Consultar tabla de 5130. Pag. 84 / See table of 5130. Page 84

MATERIALES / MATERIALS

Consultar gráfico y tabla de materiales de 5130. Pag. 83
See chart and table of materials of 5130. Page 83

5131

VÁLVULA DE GLOBO EN FUNDICIÓN EMBRIDADA PN-16 CAST IRON GLOBE VALVE FLANGED ENDS PN-16

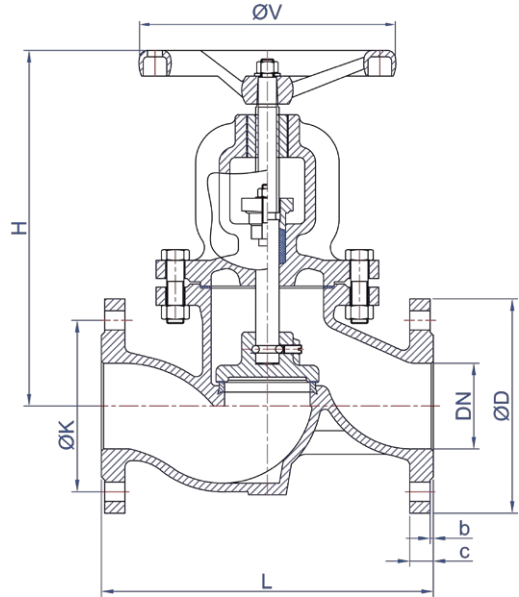

- Fabricado en acero al carbono GG-25
Made of ductile iron GG-25
- Recubrimiento en pintura Epoxy RAL5013 (250µ)
Epoxy coating Epoxy RAL5013 (250µ)
- Asiento en acero inoxidable AISI-304
Stainless steel seat AISI-304
- Juntas de grafito
Graphite gaskets

- Fabricado bajo normativa:
DIN 86251, DIN 2501, DIN3202 F1, EN-1092-2 PN16
Manufactured according to standards:
DIN 86251, DIN 2501, DIN3202 F1, EN-1092-2 PN16
- Presión máxima de trabajo: 16 Bar (PN16)
Working pressure (Max): 16 Bar (PN16)
- Temperatura de trabajo: -20°C / 200°C
Working temperature: -20°C / 200°C

DIMENSIONES / DIMENSIONS

CÓDIGO	MEDIDA	DN	L	H	ØK	ØD	ØV	c	b	TORN	€
CODE	SIZE	DN	L	H	ØK	ØD	ØV	c	b	BOLTS	€
5131-015	1/2"	15	130	180	65	95	80	14	2	4xM12	41,22
5131-020	3/4"	20	150	190	75	105	80	16	3	4xM12	45,16
5131-025	1"	25	160	220	85	115	100	16	3	4xM12	53,58
5131-032	1 1/4"	32	180	222	100	140	120	18	3	4xM16	63,42
5131-040	1 1/2"	40	200	252	110	150	140	18	3	4xM16	86,74
5131-050	2"	50	230	263	125	165	140	20	3	4xM16	99,43
5131-065	2 1/2"	65	290	295	145	185	160	20	3	4xM16	131,15
5131-080	3"	80	310	330	160	200	240	22	3	8xM16	212,92
5131-100	4"	100	350	350	180	220	240	24	3	8xM16	276,35
5131-125	5"	125	400	420	210	250	280	26	3	8xM16	411,00
5131-150	6"	150	480	455	240	285	320	26	3	8xM20	609,79
5131-200	8"	200	600	550	295	340	360	30	3	12xM20	1.025,61

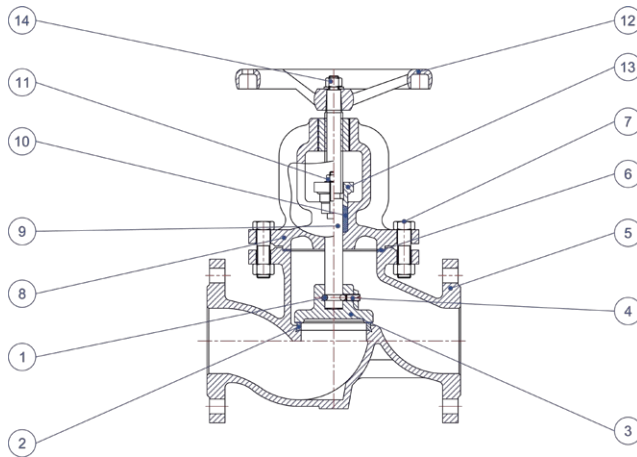

MATERIALES / MATERIALS

Nº	NOMBRE	MATERIALES	CALIDAD
Nº	NAME	MATERIALS	QUALITY
1	Cierre seguridad Circlip	Acero Steel	-
2	Anillo de asiento Seat ring	Acero inoxidable Stainless steel	-
3	Disco Disc	Hierro fundido + INOX. Cast iron + S.S.	EN-GJL-250 + AISI 304
4	Tornillo ciego Blind screw	Acero al carbono Carbon steel	-
5	Cuerpo Body	Hierro fundido Cast iron	EN-GJL-250
6	Junta tapa Bonnet gasket	Grafito Graphite	-
7	Tornillo-tuerca Bolt-nut	Acero al carbono Carbon steel	-
8	Tapa Bonnet	Hierro fundido Cast iron	EN-GJL-250
9	Eje Stem	Acero inoxidable Stainless steel	-
10	Estopa Packing	Grafito Graphite	-
11	Tornillo-tuerca Bolt-nut	Acero al carbono Carbon steel	-
12	Volante Wheel	Hierro fundido Cast iron	EN-GJL-250
13	Prensaestopa Packing gland	Hierro fundido Cast iron	EN-GJL-250
14	Arandela-tuerca Washer-nut	Acero al carbono Carbon steel	-

COEFICIENTE DE CAUDAL (KV) FLOW FACTOR (KV)

MEDIDA	DN	Kv
SIZE	DN	Kv
1/2"	15	4,1
3/4"	20	7,1
1"	25	11,8
1 1/4"	32	18,5
1 1/2"	40	29,6
2"	50	46,5
2 1/2"	65	77
3"	80	120,5
4"	100	186
5"	125	286
6"	150	405
8"	200	733

GRÁFICO PRESIÓN-TEMPERATURA PRESSURE-TEMPERATURE CHART

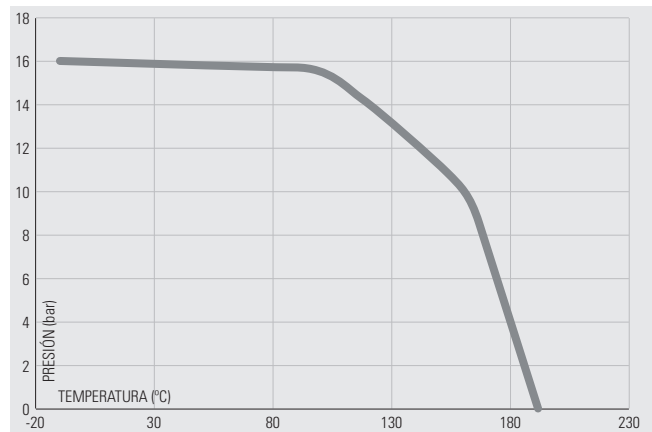

5137

VÁLVULA ESFERA DOS PIEZAS DE HIERRO FUNDIDO CON BRIDAS
BALL VALVE TWO PIECES CAST IRON WITH FLANGES

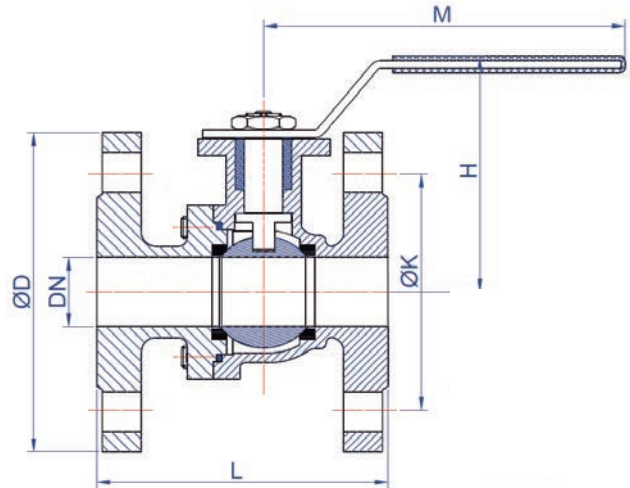

- Cuerpo fabricado en fundición gris (EN-GJL-250)
Body made of cast iron (EN-GJL-250)
- Bola fabricada en acero inoxidable (AISI-201)
Stainless steel (AISI-201) ball
- Asientos de bola de PTFE
Ball seats made of PTFE
- Juntas en PTFE
PTFE seat gaskets

- Bidas s/ UNE EN1092-2 PN16
Flanges according to UNE EN1092-2 PN16
- Cara a cara s/ UNE EN 558-1
Face to face according to UNE EN 558-1
- Presión Máxima de trabajo: 16 Bar
Working pressure (Max): 16 Bar
- Temperatura de trabajo: -20°C / 120°C
Working temperature: -20°C / 120°C

DIMENSIONES / DIMENSIONS

CÓDIGO	MEDIDA	DN	L	H	ØD	ØK	M	TORN	€
CODE	SIZE	DN	L	H	ØD	ØK	M	TORN	€
5137-015	1/2"	15	115	76	95	65	110	4xM12	67,26
5137-020	3/4"	20	120	81	105	75	110	4xM12	77,19
5137-025	1"	25	125	90	115	85	160	4xM12	105,91
5137-032	1 1/4"	32	130	102	140	100	160	4xM16	126,02
5137-040	1 1/2"	40	140	115	150	110	185	4xM16	157,35
5137-050	2"	50	150	122	165	125	185	4xM16	176,27
5137-065	2 1/2"	65	170	168	185	145	305	4xM16	277,16
5137-080	3"	80	180	178	200	160	305	8xM16	382,60
5137-100	4"	100	190	198	220	180	305	8xM16	496,80
5137-125	5"	125	325	234	250	210	500	8xM16	820,39
5137-150	6"	150	350	288	285	240	645	8xM20	1.366,22

- Disponible hasta agotar existencias
While stocks lasts

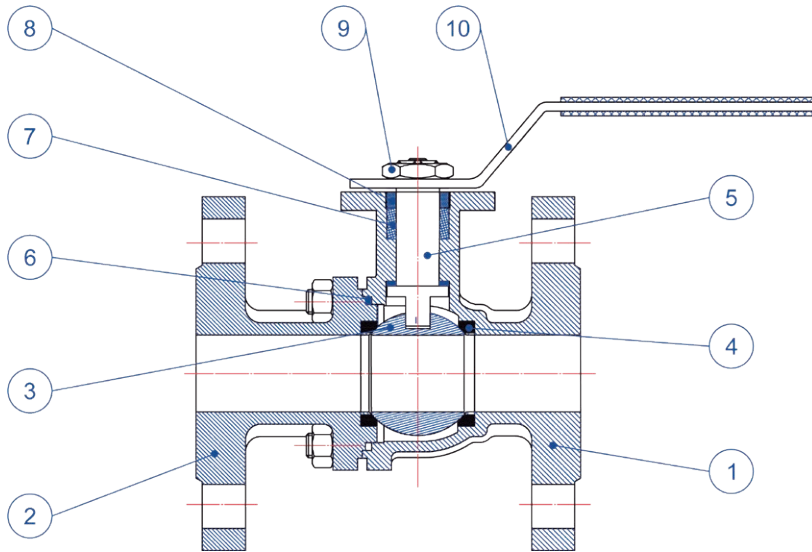

MATERIALES / MATERIALS

Nº	NOMBRE	MATERIALES	CALIDAD
Nº	NAME	MATERIALS	QUALITY
1	Cuerpo Body	Fundición gris Cast iron	GG25
2	Tapa Bonnet	Fundición gris Cast iron	GG25
3	Bola Ball	Acero inoxidable Stainless steel	AISI A-201
4	Asiento bola Ball seat	PTFE	PTFE
5	Eje Stem	Acero inoxidable Stainless steel	AISI A-420
6	Junta tapa Bonnet gasket	PTFE	PTFE
7	Empaquetadura eje Stem packing	PTFE	PTFE
8	Tuerca prensaestopa Packing gland	Acero al carbono Carbon steel	-
9	Tuerca eje Stem nut	Acero Steel	Zinc Plated
10	Maneta Handle	Acero Steel	Zinc Plated

5145

VÁLVULA ESFERA PASO REDUCIDO UNA PIEZA ONE PIECE REDUCED BORE BALL VALVE

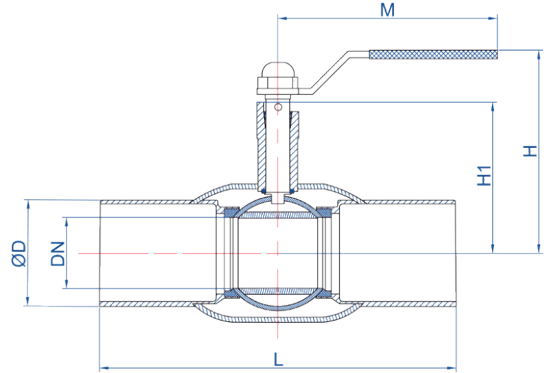

- Cuerpo fabricado en fundición gris (EN-GJL-250)
Body made of cast iron (EN-GJL-250)
- Bola fabricada en acero inoxidable AISI-304
AISI-304 stainless steel ball
- Asientos de bola de PTFE reforzado
Ball seats made of reinforced PTFE
- Eje en acero inoxidable AISI-420
AISI-420 stainless steel stem
- Terminación a soldar según UNE-EN-12627
Welding ends according UNE-EN-12627
- Presión máxima de trabajo: DN25-50: 40 Bar
DN65-300MR*: 25 Bar
Working pressure: DN25-50: 40 Bar
DN65-300MR*: 25 Bar
- Temperatura de trabajo: -30°C / 200°C
Working temperature: -30°C / 200°C

DIMENSIONES / DIMENSIONS

CÓDIGO	MEDIDA	DN	L	H	H1	ØD	M	€
CODE	SIZE	DN	L	H	H1	ØD	M	€
5145-015	½"	10	230	75	65	33	156	33,98
5145-020	¾"	15	230	92	65	42	156	38,47
5145-025	1"	20	230	84	65	48	156	49,57
5145-032	1 1/4"	25	260	95	76	60	175	60,64
5145-040	1 1/2"	32	260	103	84	76	175	81,20
5145-050	2"	40	300	110	91	89	245	98,89
5145-065	2 ½"	50	300	119	100	108	245	139,80
5145-080	3"	65	300	139	110,5	133	245	193,45
5145-100	4"	80	325	156	129,5	159	245	277,53
5145-125	5"	100	325	185	138,5	193	372	448,38
5145-150	6"	125	350	203	192,5	219	530	560,53
5145-200	8"	150	400	230	223,5	279	620	1.012,55
5145-250MR*	10"	250	560	380	370,5	410	340	2.703,00
5145-300MR*	12"	300	560	380	370,5	410	340	3.859,43

- * Reductor manual
* Gear operator

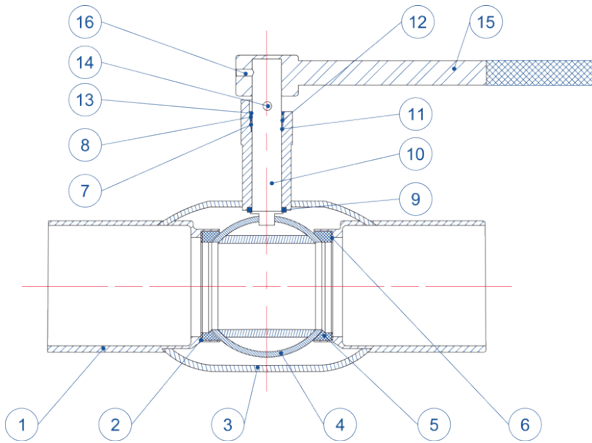

DN15 - DN40

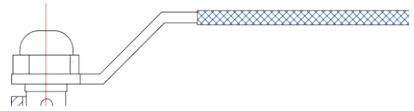

DN50 - DN200



DN250 - DN300

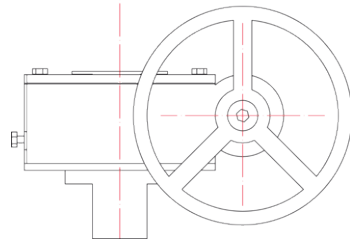

MATERIALES / MATERIALS

Nº	NOMBRE	MATERIALES	CALIDAD
Nº	NAME	MATERIALS	QUALITY
1	Terminación a soldar Welding end	St 37.0 Cast iron	GG25
2	Muelle Mariposa Ball seat	65Mn Cast iron	GG25
3	Cuerpo Body	St 37.0 Stainless steel	A-201
4	Bola Ball	AISI 304 PTFE	PTFE
5	Asiento Seat	PTFE + 20% Graphite stainless steel	A-420
6	Anillo soporte Backup ring	AISI 420 PTFE	PTFE
7	Junta plana Flat gasket	EPDM PTFE	PTFE
8	Junta tórica O-ring	FKM Carbon steel	-
9	Cierre eje Stem seal	PTFE + 20% Graphite steel	Zincate
10	Eje Stem	AISI 420 Steel	Zinc-plated
11	Anillo soporte Backup ring	PTFE + 20% Graphite	-
12	Anillo intermedio Intermediate ring	St 37.0	-
13	Anillo de seguridad Safety clip	-	-
14	Pasador Stop pin	St 37.0	-
15	Maneta Handle	St 37.0 Chromed	-
16	Tornillo fijación Handle locking screw	St 37.0	-

CALIDAD

Fundición gris GG25
Fundición nodular
GGG40-GGG50

QUALITY

Cast iron GG25
Ductile iron
GGG40- GGG50

NORMAS DE FABRICACIÓN

DIN 1691/1 UNE EN 1561
DIN 1693 / UNE EN 1563
UNE-EN-1074

MANUFACTURING STANDARDS

DIN 1691/1 UNE EN 1561
DIN 1693 / UNE EN 1563
UNE-EN-1074

**LEYENDA DE ICONOS
ICON KEY**

Posibles codificaciones
aplicadas en esta sección.

Possible encodings applied
in this section.



**CERTIFICADOS DE PRODUCTO
PRODUCT CERTIFICATES**



Recambios
Spare parts

**PROPIEDADES DE PRODUCTO
PRODUCT PROPERTIES**

VÁLVULAS DE MARIPOSA

BUTTERFLY VALVES

VÁLVULAS DE MARIPOSA

BUTTERFLY VALVES



VÁLV. IND. MARIPOSA
BUTTERFLY IND. VAL.

APLICACIONES

Heating, air conditioning and ventilating.
Water treatment and distribution systems.
Mining industry.
Shipbuilding and off-shore industries.
Chemical and petrochemical plants. Sugar industry.
Food and chemistry processing. Oil and gas .
Fire fighting systems.
Sanitary systems.

APLICACIONES

Calefacción, ventilación y aire acondicionado.
Tratamiento y sistemas de distribución de agua.
Industria de la minería.
Construcciones navales
Plantas químicas y petroquímicas. Industria azucarera.
Procesos químicos y alimentación. Gas y aceite.
Sistemas contraincendios.
Sistemas sanitarios.

5114

VÁLVULA DE MARIPOSA TIPO WAFER DISCO INOXIDABLE ASIENTO BLANDO EPDM
BUTTERFLY VALVE WAFER TYPE STAINLESS STEEL DISC EPDM SOFT SEAT

WRAS

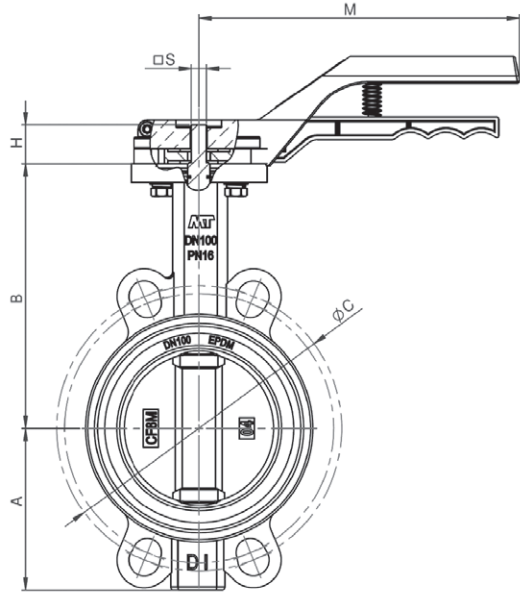

- Fabricado en fundición Nodular GGG-40 (GJS-400)
Made of ductile Iron GGG-40 (GJS-400)
- Recubrimiento en pintura Epoxy RAL5013
Epoxy coating Epoxy RAL5013
- Disco acero inoxidable AISI-316
Stainless steel disc AISI-316
- Diseño s/ EN-12334, DIN 3202, EN 558-1
Design according to EN-12334, DIN 3202, EN 558-1
- Bridas s/ UNE EN-1092-2 PN10-PN16 Ansi B16.5 Clase 125/150
Flanges according to UNE EN-1092-2 PN10-PN16 Ansi B16.5 Class 125/150

- Presión máxima de trabajo:
2"-10": 16 Bar (250PSI) 12": 10 Bar
Working pressure (Max):
2"-10": 16 Bar (250PSI) 12": 10 Bar
- Temperatura de trabajo: -20°C/120°C
Working temperature: -20°C / 120°C

DIMENSIONES / DIMENSIONS

CÓDIGO	MEDIDA DN	DN	A	B	H	S	ANCHO	ØC	ØC	M	€
CODE	DN SIZE	DN	A	B	H	□S	WIDTH	PN10/16	ANSI 125/150	M	€
5114-040	1 1/2"	40	-	-	-	-	-	-	-	-	72,16
5114-050	2"	50	62	141	25	11	43	125	120,6	210	72,16
5114-065	2 1/2"	65	72	153	25	11	46	145	139,7	210	82,12
5114-080	3"	80	87	161	25	11	46	160	152,4	210	89,67
5114-100	4"	100	106	178	25	11	52	180	190,5	210	125,63
5114-125	5"	125	123	193	25	14	56	210	215,9	210	192,74
5114-150	6"	150	138	204	25	14	56	240	241,3	210	197,51
5114-200	8"	200	173	247	35	17	60	295	298,4	340	361,73
5114-250	10"	250	212	277	35	17	68	350/355	361,9	400	517,43
5114-300*	12"	300	223	337	40	22	78	410/400	431,8	350	752,37

• *Disponibile hasta agotar existencias
*While stocks lasts

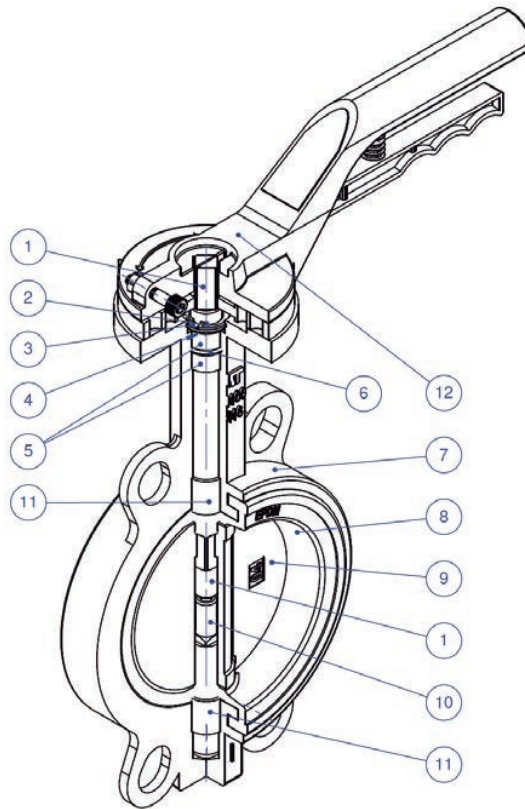

MATERIALES / MATERIALS

Nº	NOMBRE	MATERIALES	CALIDAD
Nº	NAME	MATERIALS	QUALITY
1	Eje superior Upper stem	Acero Inoxidable Stainless steel	ASTM A420
2	Anillo elástico Cir clip	Acero para muelles Spring steel	ASTM A29M
3	Arandela plana Flat gasket	Acero al carbono Carbon steel	Q235
4	Arandela curva Clam spring	Acero para muelles Spring steel	ASTM A29M
5	Casquillo Bushing	PTFE + FG	PTFE + FG
6	Junta tórica O-Ring	NBR	NBR
7	Cuerpo Body	Fundición dúctil Ductile iron	GGG40
8	Asiento del disco Disc seat	EPDM	EPDM Shore 70
9	Disco Disc	Acero Inoxidable Stainless steel	ASTM A276 AISI 316 EN1.4401
10	Eje inferior Lower stem	Acero Inoxidable Stainless steel	ASTM A420
11	Casquillo Bushing	PTFE + FG	PTFE + FG
12	Maneta Lever	Aluminio Aluminium	Aluminium

5114MR

VÁLVULA MARIPOSA TIPO WAFER ASIENTO BLANDO EPDM REDUCTOR MANUAL
BUTTERFLY VALVE WAFER TYPE EPDM SOFT SEAT GEAR OPERATOR

WRAS

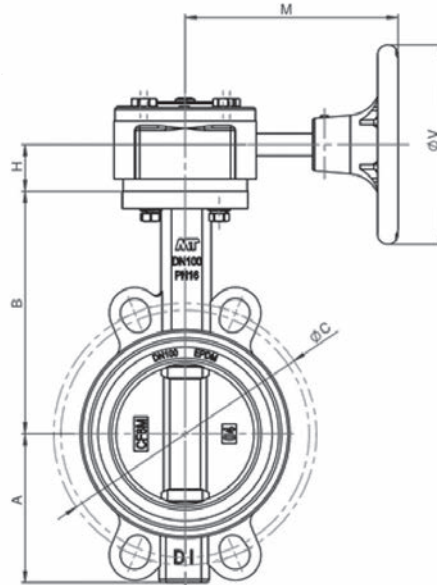

- Fabricado en fundición Nodular GGG-40 (GJS-400)
Made of ductile Iron GGG-40 (GJS-400)
- Recubrimiento en pintura Epoxy RAL5013
Epoxy coating RAL5013
- Disco acero inoxidable AISI-316
Stainless steel disc AISI-316
- Asiento elastómero EPDM asiento blando
EPDM seat gasket soft seat
- Diseño s/ EN-12334, DIN 3202, EN 558-1
Design according to EN-12334, DIN 3202, EN 558-1

- Bridas s/ UNE EN-1092-2 PN10-PN16 Ansi B16.5 Clase 125/150
Flanges according to UNE EN-1092-2 PN10-PN16 Ansi B16.5 Class 125/150
- Presión máxima de trabajo: 2"-12": 16 Bar (250PSI)
14"-24": 10 Bar (150PSI)
Working pressure (Max): 2"-12": 16 Bar (250PSI)
14"-24": 10 Bar (150PSI)
- Temperatura de trabajo: -20°C / 120°C
Working temperature: -20°C / 120°C

DIMENSIONES / DIMENSIONS

CÓDIGO	MEDIDA DN	DN	A	B	H	ØV	M	ANCHO	ØC	ØC	€
CODE	DN SIZE	DN	A	B	H	ØV	M	WIDTH	PN10/16	ANSI 125/150	€
5114-050MR	2"	50	62	141	25	145	160	43	125	120,6	153,46
5114-065MR	2 ½"	65	72	153	25	145	160	46	145	139,7	160,63
5114-080MR	3"	80	87	161	25	145	160	46	160	152,4	163,02
5114-100MR	4"	100	106	178	25	145	160	52	180	190,5	201,16
5114-125MR	5"	125	123	193	25	145	160	56	210	215,9	243,19
5114-150MR	6"	150	138	204	25	145	160	56	240	241,3	250,98
5114-200MR	8"	200	173	247	35	300	240	60	295	298,4	467,74
5114-250MR	10"	250	212	277	35	300	240	68	350/355	361,9	607,20
5114-300MR	12"	300	253	324	45	300	240	78	400/410	431,8	890,84
5114-350MR	14"	350	267	337,5	45	300	240	78	460/470	476,2	1.290,30
5114-400MR	16"	400	320	400	55	300	280	102	515/525	539,7	2.416,59
5114-500MR	20"	500	363	485	57,5	285	172	127	620/650	635	3.830,60
5114-600MR	24"	600	440	565	70	400	205	154	725/770	749,3	6.321,61

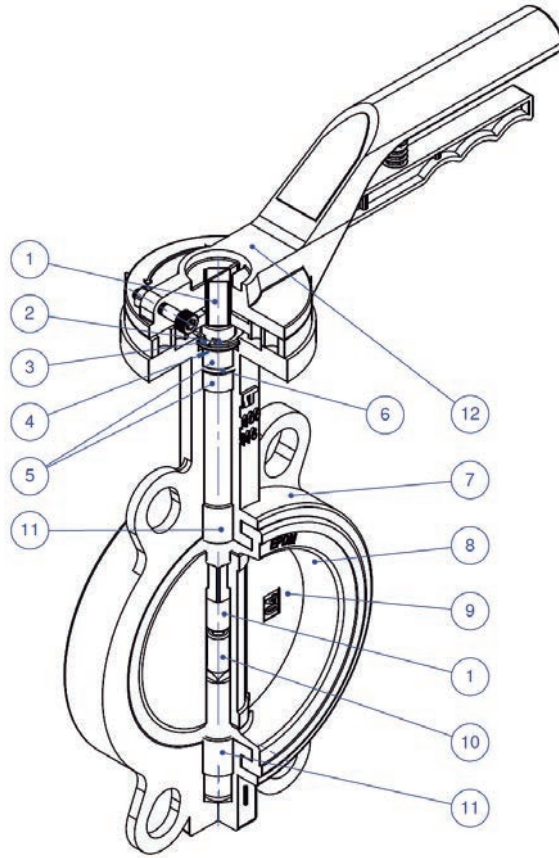

MATERIALES / MATERIALS

Nº	NOMBRE	MATERIALES	CALIDAD
Nº	NAME	MATERIALS	QUALITY
1	Eje superior Upper stem	Acero inoxidable Stainless steel	ASTM A420
2	Anillo elástico Cir clip	Acero para muelles Spring steel	ASTM A29M
3	Arandela plana Flat gasket	Acero al Carbono Carbon Steel	Q235
4	Arandela curva Clam spring	Acero para muelles Spring steel	ASTM A29M
5	Casquillo Bushing	PTFE + FG	PTFE +FG
6	Junta tórica O-Ring	NBR	NBR
7	Cuerpo Body	Fundición Ductil Ductile Iron	GGG40
8	Asiento del disco Disc seat	EPDM	EPDM Shore 70
9	Disco Disc	Acero Inoxidable Stainless steel	ASTM A276 AISI 316 EN1.4401
10	Eje inferior Lower stem	Acero Inoxidable Stainless steel	ASTM A420
11	Casquillo Bushing	PTFE + FG	PTFE +FG
12	Reductor Manual Gear Box	Fundición Cast Iron	GG25

51142

VÁLVULA DE MARIPOSA TIPO WAFER DISCO INOXIDABLE ASIENTO BLANDO NBR
BUTTERFLY VALVE WAFER TYPE STAINLESS STEEL DISC NBR SOFT SEAT

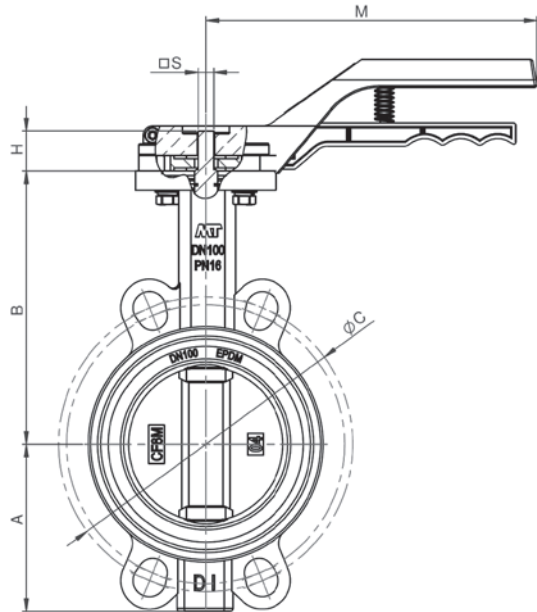

- Fabricado en fundición Nodular GGG-40 (GJS-400)
Made of ductile Iron GGG-40 (GJS-400)
- Recubrimiento en pintura Epoxy RAL5013
Epoxy coating Epoxy RAL5013
- Disco acero inoxidable AISI-316
Stainless steel disc AISI-316
- Diseño s/ EN-12334, DIN 3202, EN 558-1
Design according to EN-12334, DIN 3202, EN 558-1

- Bridas s/ UNE EN-1092-2 PN10-PN16 Ansi B16.5 Clase 125/150
Flanges according to UNE EN-1092-2 PN10-PN16 Ansi B16.5 Class 125/150
- Presión máxima de trabajo:
2"-10": 16 Bar (250PSI)
Working pressure (Max):
2"-10": 16 Bar (250PSI)
- Temperatura de trabajo: -20°C/80°C
Working temperature: -20°C / 80°C

DIMENSIONES / DIMENSIONS

CÓDIGO	MEDIDA DN	DN	A	B	H	□ S	ANCHO	ØC	ØC	M	€
CODE	DN SIZE	DN	A	B	H	□ S	WIDTH	PN10/16	ANSI 125/150	M	€
51142-050	2"	50	62	141	25	11	43	125	120,6	210	75,77
51142-065	2 ½"	65	72	153	25	11	46	145	139,7	210	86,23
51142-080	3"	80	87	161	25	11	46	160	152,4	210	94,16
51142-100	4"	100	106	178	25	11	52	180	190,5	210	131,91
51142-125	5"	125	123	193	25	14	56	210	215,9	210	202,37
51142-150	6"	150	138	204	25	14	56	240	241,3	210	207,39
51142-200	8"	200	173	247	35	17	60	295	298,4	340	379,81
51142-250	10"	250	212	277	35	17	68	350/355	361,9	400	543,29

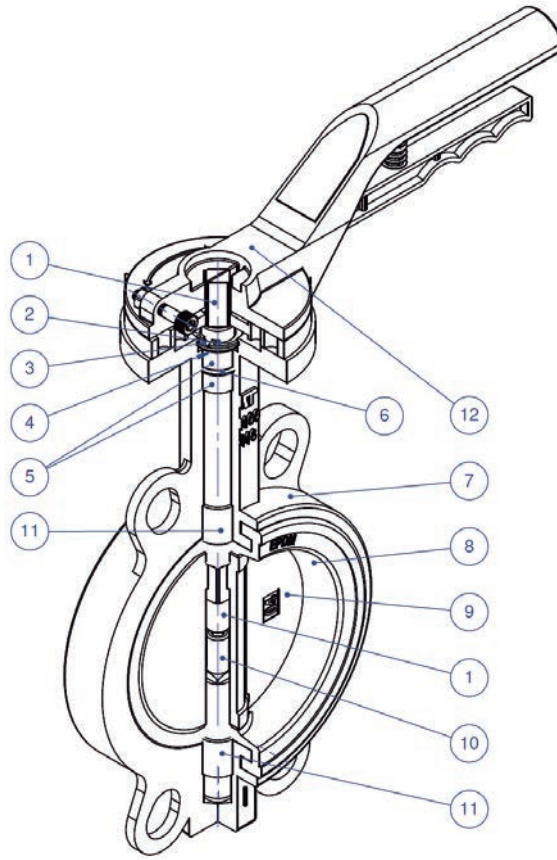

MATERIALES / MATERIALS

Nº	NOMBRE	MATERIALES	CALIDAD
Nº	NAME	MATERIALS	QUALITY
1	Eje superior Upper stem	Acero Inoxidable Stainless steel	ASTM A420
2	Anillo elástico CirClip	Acero para muelles Spring steel	ASTM A29M
3	Arandela plana Flat gasket	Acero al Carbono Carbon steel	Q235
4	Arandela curva Clam spring	Acero para muelles Spring steel	ASTM A29M
5	Casquillo Bushing	PTFE + FG	PTFE +FG
6	Junta tórica O-Ring	NBR	NBR
7	Cuerpo Body	Fundición dúctil Ductile iron	GGG40
8	Asiento del disco Disc seat	NBR	NBR Shore 70
9	Disco Disc	Acero Inoxidable Stainless steel	ASTM A276 AISI 316 EN1.4401
10	Eje inferior Lower stem	Acero Inoxidable Stainless steel	ASTM A420
11	Casquillo Bushing	PTFE + FG	PTFE +FG
12	Maneta Lever	Aluminio Aluminium	Aluminium

5140

VÁLVULA MARIPOSA TIPO WAFER EPDM DISCO POLIAMIDA 11
BUTTERFLY VALVE WAFER TYPE EPDM POLYAMIDE 11 DISC

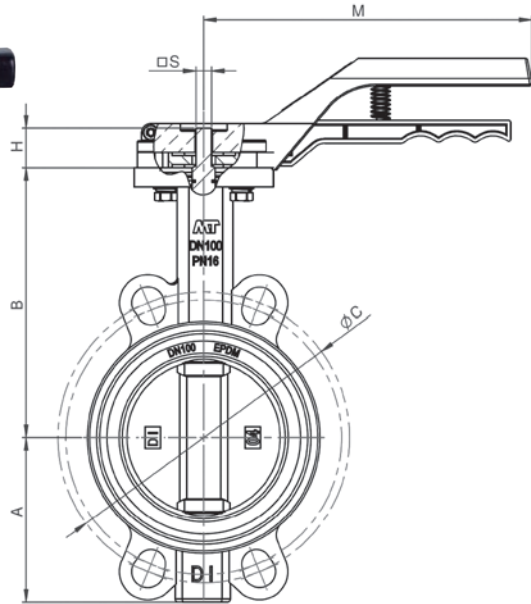

- Fabricado en fundición nodular GGG-40 (GJS-400)
Made of ductile iron GGG-40 (GJS-400)
- Recubrimiento en pintura Epoxy RAL3020 (250µ)
Epoxy coating RAL3020 (250µ)
- Disco fundición con recubrimiento en poliamida 11 (200µ)
Disc on ductile iron with polyamide 11 coating (200µ)
- Asiento EPDM
EPDM seat gasket

- Bridas según UNE EN1092-2 PN-10/PN-16
ANSI B16.5 Clase 125/150
Flanges according to UNE EN1092-2 PN-10/PN-16
ANSI B16.5 Class 125/150
- Presión máxima de trabajo: 16 Bar (PN-16)
Working pressure (max): 16 Bar (PN-16)
- Temperatura de trabajo: -20°C / 120°C
Working temperatura: -20°C / 120°C

DIMENSIONES / DIMENSIONS

CÓDIGO	MEDIDA DN	DN	A	B	H	S	ANCHO	ØC	ØC	M	€
CODE	DN SIZE	DN	A	B	H	S	WIDTH	PN10/16	ANSI 125/150	M	€
5140-050	2"	50	62	141	25	11	43	125	120,6	210	58,31
5140-065	2 ½"	65	72	153	25	11	46	145	139,7	210	65,34
5140-080	3"	80	87	161	25	11	46	160	152,4	210	75,33
5140-100	4"	100	106	178	25	11	52	180	190,5	210	104,28
5140-125	5"	125	123	193	25	14	56	210	215,9	210	147,13
5140-150	6"	150	138	204	25	14	56	240	241,3	210	156,84
5140-200	8"	200	173	247	35	17	60	295	298,4	340	266,61
5140-250	10"	250	212	277	35	17	68	350/355	361,9	400	340,25

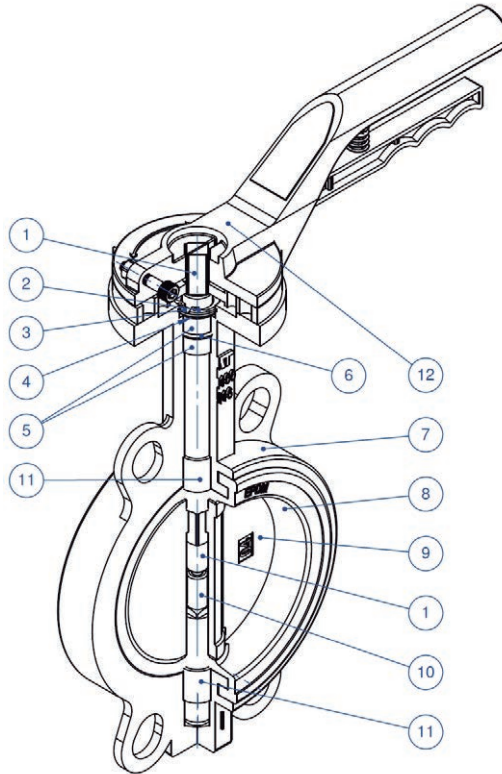

MATERIALES / MATERIALS

Nº	NOMBRE	MATERIALES	CALIDAD
Nº	NAME	MATERIALS	QUALITY
1	Eje superior Upper stem	Acero Inoxidable Stainless steel	ASTM A420
2	Anillo elástico Cir clip	Acero para muelles Spring steel	ASTM A29M
3	Arandela plana Flat gasket	Acero al Carbono Carbon steel	Q235
4	Arandela curva Clam spring	Acero para muelles Spring steel	ASTM A29M
5	Casquillo Bushing	PTFE + FG	PTFE +FG
6	Junta tórica O-Ring	NBR	NBR
7	Cuerpo Body	Fundición Ductil Ductile Iron	GGG40
8	Asiento del disco Disc seat	EPDM	EPDM Shore 70
9	Disco Disc	Fundición Ductil + Poliamida 11 Ductile Iron + Polyamide 11	GGG-40 + Poliamida 11
10	Eje inferior Lower stem	Acero Inoxidable Stainless steel	ASTM A420
11	Casquillo Bushing	PTFE + FG	PTFE +FG
12	Maneta Lever	Aluminio Aluminium	Aluminium

5141

VÁLVULA MARIPOSA TIPO WAFERDISCO INOXIDABLE ASIENTO BLANDO EPDM
BUTTERFLY VALVE WAFER TYPE STAINLESS STEEL DISC EPDM SOFT SEAT

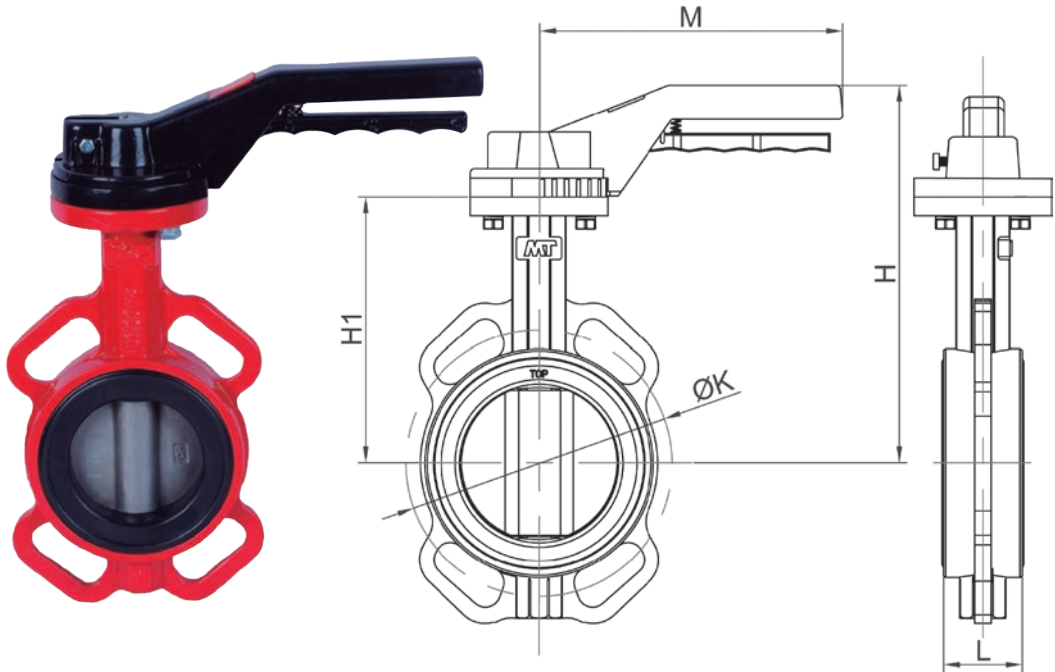

- Fabricado en fundición nodular GGG-40 (GJS-400)
Made of ductile iron GGG-40 (GJS-400)
- Recubrimiento en pintura Epoxy RAL3020 (250µ)
Epoxy coating RAL3020 (250µ)
- Disco acero inoxidable AISI-316
Stainless steel disc AISI-316
- Asiento EPDM
EPDM seat gasket
- Bridas según UNE EN1092-2 PN-10/PN-16

- ANSI B16.5 Clase 125/150
Flanges according to UNE EN1092-2 PN-10/PN-16
ANSI B16.5 Class 125/150
- Presión máxima de trabajo: 16 Bar (PN-16)
Working pressure (max): 16 Bar (PN-16)
- Temperatura de trabajo: -20°C / 120°C
Working temperatura: -20°C / 120°C

DIMENSIONES / DIMENSIONS

CÓDIGO	MEDIDA DN	DN	L	H	H1	ØK			M	€
CODE	DN SIZE	DN	L	H	H1	PN10	PN16	ANSI150	M	€
5141-040	1 1/2"	40	33	215	136	110	110	98,6	215	57,14
5141-050	2"	50	43	225,5	140,5	125	125	120,6	215	60,87
5141-065	2 1/2"	65	46	238	153	145	145	139,7	215	71,61
5141-080	3"	80	46	242,5	157,5	160	160	152,4	215	80,86
5141-100	4"	100	52	261	176	180	180	190,5	215	121,40
5141-125	5"	125	56	276	191	210	210	215,9	215	174,93
5141-150	6"	150	56	287,5	202,5	240	240	241,3	215	204,91
5141-200	8"	200	60	338,5	243,5	295	295	298,4	355	374,98
5141-250	10"	250	68	368	273	350	355	361,9	355	576,74

- Disponible hasta agotar existencias
While stocks lasts

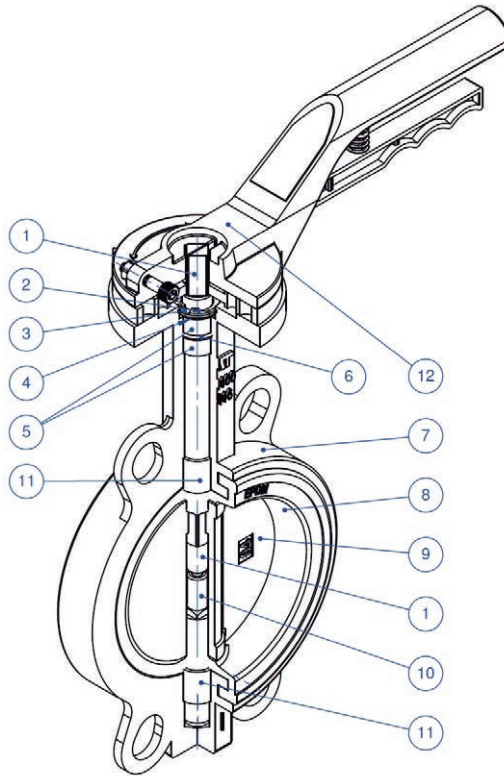

MATERIALES / MATERIALS

Nº	NOMBRE	MATERIALES	CALIDAD
Nº	NAME	MATERIALS	QUALITY
1	Eje superior Upper stem	Acero Inoxidable Stainless steel	ASTM A420
2	Anillo elástico Cir clip	Acero para muelles Spring steel	ASTM A29M
3	Arandela plana Flat gasket	Acero al Carbono Carbon Steel	Q235
4	Arandela curva Clam spring	Acero para muelles Spring steel	ASTM A29M
5	Casquillo Bushing	PTFE + FG	PTFE +FG
6	Junta tórica O-Ring	NBR	NBR
7	Cuerpo Body	Fundición Ductil Ductile Iron	GGG40
8	Asiento del disco Disc seat	EPDM	EPDM Shore 70
9	Disco Disc	Acero Inoxidable Stainless steel	ASTM A276 AISI 316 EN1.4401
10	Eje inferior Lower stem	Acero Inoxidable Stainless steel	ASTM A420
11	Casquillo Bushing	PTFE + FG	PTFE +FG
12	Maneta Lever	Aluminio Aluminium	Aluminium

51151

VÁLVULA DE MARIPOSA TIPO WAFER DISCO INOXIDABLE ASIENTO RÍGIDO EPDM
BUTTERFLY VALVE WAFER TYPE STAINLESS STEEL DISC EPDM HARD SEAT

ECO

NUEVO
NEW

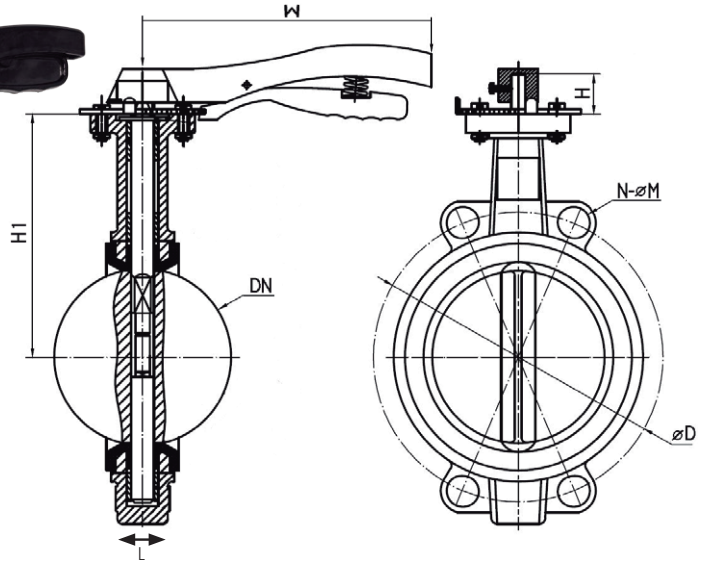

- Fabricado en fundición gris DN50-DN150 GG25 y fundición dúctil >DN200 GGG-40
Made of cast iron DN25-DN150 GG25 and ductil iron >DN200 GGG-40
- Recubrimiento en pintura Epoxy RAL5013
Epoxy coating epoxy RAL5013
- Disco acero inoxidable AISI-316
Stainless steel disc AISI-316
- Material asiento: EPDM
Seat gasket material: EPDM

- Diseño s/ EN-12334, DIN 3202, EN 558-1
Design according to EN-12334, DIN 3202, EN 558-1
- PN-10/PN-16 Ansi B16.5 Clase 125/150
Flanges according to UNE EN-1092-2 PN-10/PN-16 Ansi B16.5 Class 125/150
- Presión máxima de trabajo: 16 Bar (250 psi)
Working pressure (max): 16 Bar (250 psi)
- Temperatura de trabajo: -20°C/120°C
Working temperature: -20°C/120°C

DIMENSIONES / DIMENSIONS

CÓDIGO CODE	MEDIDA DN DN SIZE	DN	L	H	H1	W	Bridas / Flanges (EN-1092)									€
							PN 10			PN 16			ANSI 125/150			
							ØD	N-ØM	α°	ØD	N-ØM	α°	ØD	N-ØM	α°	
51151-050	2"	50	43	25	131	170	125	4-M16	90	125	4-M16	90	120,6	4-19	90	52,93
51151-065	2 1/2"	65	46	25	142	170	145	4-M16	90	145	4-M16	90	139,7	4-19	90	62,27
51151-080	3"	80	46	25	150	170	160	4-M16	45	160	4-M16	45	152,4	4-19	90	70,34
51151-100	4"	100	52	28	170	215	180	4-M16	45	180	4-M16	45	190,5	4-19	45	105,56
51151-125	5"	125	56	28	185	215	210	4-M16	45	210	4-M16	45	215,9	4-22,4	45	152,11
51151-150	6"	150	56	28	205	215	240	4-M20	45	240	4-M20	45	241,3	4-22,4	45	178,18
51151-200	8"	200	60	30	240	265	295	4-M20	45	295	4-M20	30	298,4	4-22,4	45	325,63
51151-250	10"	250	68	35	270	350	350	4-M20	30	355	4-M24	30	361,9	4-25,4	30	505,55

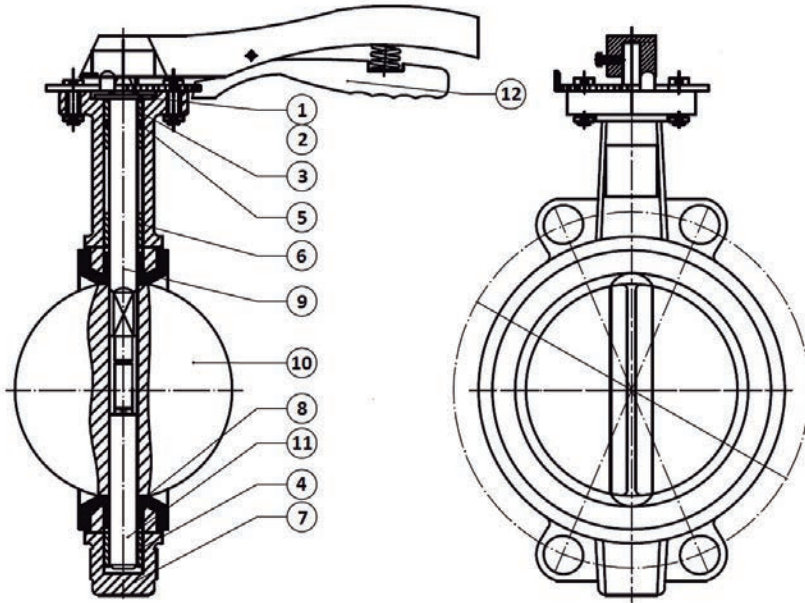

MATERIALES / MATERIALS

Nº	NOMBRE	MATERIALES	CALIDAD
Nº	NAME	MATERIALS	QUALITY
1	Cir clip Cir clip	Acero al carbono galvanizado Galvanized carbon steel	65M
2	Anillo plano Flat gasket	Acero al Carbono Carbon steel	65Mn
3	Arandela presión Clamp spring	Acero Inoxidable Stainless Steel	S201
4	Casquillo corto Short Bushing	PTFE Reforzado Reinforced PTFE	PTFE + 15% Fiber Glass
5	Junta tórica O-Ring	EPDM	Shore 70
6	Cojinete largo Long bushing	PTFE Reforzado Reinforced PTFE	PTFE + 15% Fiber Glass
7	Cuerpo Body	Fundición DN50-200 F.Ductil >DN200 Cast iron DN50-200 Ductile Iron > Dn200	GG25 – GGG40
8	Asiento Seat	EPDM	Shore 70
9	Eje superior Upper shaft	Acero Inoxidable Stainless steel	A416
10	Disco Disc	Acero Inox Stainless steel	A316 (CF8M)
11	Eje inferior Lower shaft	Acero Inoxidable Stainless steel	A416
12	Maneta Lever	Aluminio Aluminium	-

51151MR

VÁLVULA MARIPOSA TIPO WAFER DISCO INOXIDABLE CON REDUCTOR MANUAL
BUTTERFLY VALVE WAFER TYPE STAINLESS STEEL DISC WITH GEAR OPERATOR

ECO

NUEVO
NEW

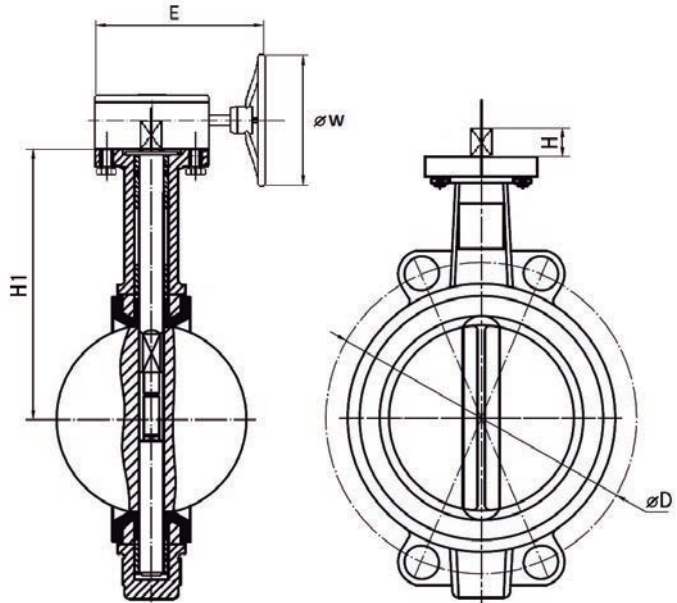

- Fabricado en fundición DN50-DN150 GG-25
Fundición dúctil >DN200 GGG-40
Made of cast iron DN50-DN150 GG-25
Ductile iron >DN200 GGG-40
- Recubrimiento en pintura Epoxy RAL5013
Epoxy coating RAL5013
- Disco acero inoxidable AISI-316
Stainless steel disc AISI-316
- Asiento elastómero EPDM
EPDM seat gasket

- Diseño s/ EN-12334, DIN 3202, EN 558-1
Design according to EN-12334, DIN 3202, EN 558-1
- Bridas según UNE EN1092-2 PN-10/PN-16
ANSI B16.5 Clase 125/150
Flanges according to UNE EN1092-2 PN-10/PN-16
ANSI B16.5 Class 125/150
- Presión máxima de trabajo: 2"-12": 16 Bar
14"-16": 10 Bar
Working pressure (max): 2"-12": 16 Bar
14"-16": 10 Bar
- Temperatura de trabajo: -20°C / 120°C
Working temperature: -20°C / 120°C

DIMENSIONES / DIMENSIONS

CÓDIGO CODE	MEDIDA DN DN SIZE	DN	H	H1	E	ØW	DIN 2576 - PN 10			DIN 2502 - PN 16			ANSI 125/150			€
							ØD	N-ØM	α°	ØD	N-ØM	α°	ØD	N-ØM	α°	
51151-050MR	2"	50	25	131	105	160	125	4-M16	90	125	4-M16	90	120,6	4-19	90	113,27
51151-065MR	2 ½"	65	25	142	165	160	145	4-M16	90	145	4-M16	90	139,7	4-19	90	118,72
51151-080MR	3"	80	25	150	165	160	160	4-M16	45	160	4-M16	45	152,4	4-19	90	122,40
51151-100MR	4"	100	25	170	165	160	180	4-M16	45	180	4-M16	45	190,5	4-19	45	158,03
51151-125MR	5"	125	25	184	165	160	210	4-M16	45	210	4-M16	45	215,9	4-22,4	45	204,59
51151-150MR	6"	150	25	200	165	160	240	4-M20	45	240	4-M20	45	241,3	4-22,4	45	230,66
51151-200MR	8"	200	35	240	165	265	295	4-M20	45	295	4-M20	30	298,4	4-22,4	45	438,15
51151-250MR	10"	250	35	270	240	265	350	4-M20	30	355	4-M24	30	361,9	4-25,4	30	572,92
51151-300MR	12"	300	35	310	240	265	400	4-M20	30	355	4-M24	30	431,8	4-25,4	30	851,53
51151-350MR	14"	350	45	368	-	-	460	4-M20	22,5	470	4-M24	22,5	476,3	4-28,5	30	1.170,13
51151-400MR	16"	400	50	400	-	-	515	4-M24	22,5	525	4-M27	22,5	539,8	4-31,8	22,5	2.124,06

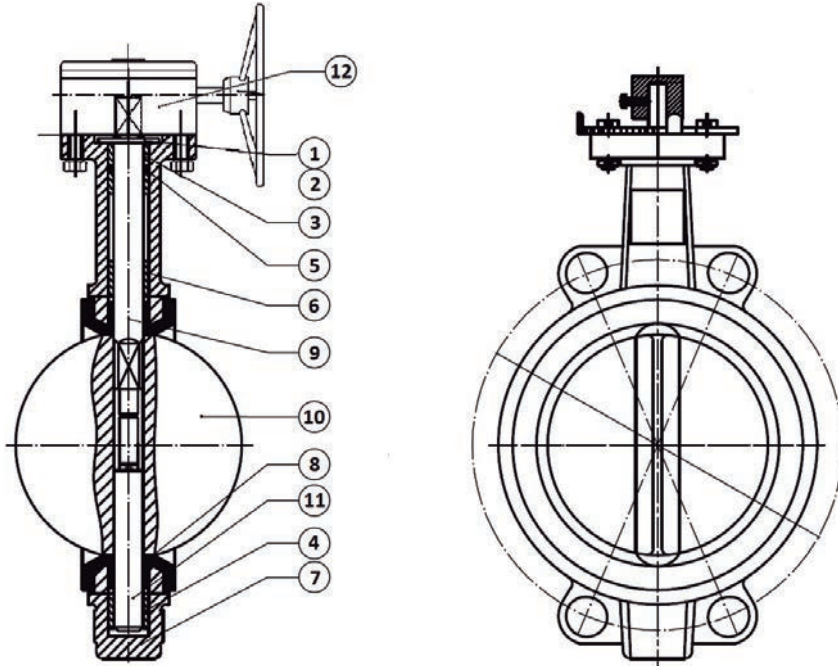

MATERIALES / MATERIALS

Nº	NOMBRE	MATERIALES	CALIDAD
Nº	NAME	MATERIALS	QUALITY
1	Cir clip Cir clip	Acero al carbono Galvanizado Galvanized carbon steel	65M
2	Anillo plano Flat gasket	Acero Inoxidable Stainless steel	S201
3	Arandela presión Clamp spring	Acero Inoxidable Stainless steel	S201
4	Casquillo corto Short bushing	PTFE reforzado Reinforced PTFE	PTFE + 15% Fiber Glass
5	Junta tórica O-Ring	EPDM	Shore 70
6	Cojinete largo Long bushing	PTFE Reforzado Reinforced PTFE	PTFE + 15% Fiber Glass
7	Cuerpo Body	Fundición DN50-200 F.Ductil >DN200 Cast iron DN50-200 Ductile Iron > Dn200	GG25 – GGG40
8	Asiento Seat	EPDM	Shore 70
9	Eje superior Upper shaft	Acero Inoxidable Stainless steel	A416
10	Disco Disc	Acero Inox Stainless steel	A316 (CF8M)
11	Eje inferior Lower shaft	Acero Inoxidable Stainless steel	A416
12	Reductor Manual Gear box	Fundición Cast iron	GG25

5115

VÁLVULA DE MARIPOSA TIPO WAFER DISCO CROMADO ASIENTO RÍGIDO EPDM
BUTTERFLY VALVE WAFER TYPE CHROMED DISC EPDM HARD SEAT

ECO

**NUEVO
NEW**

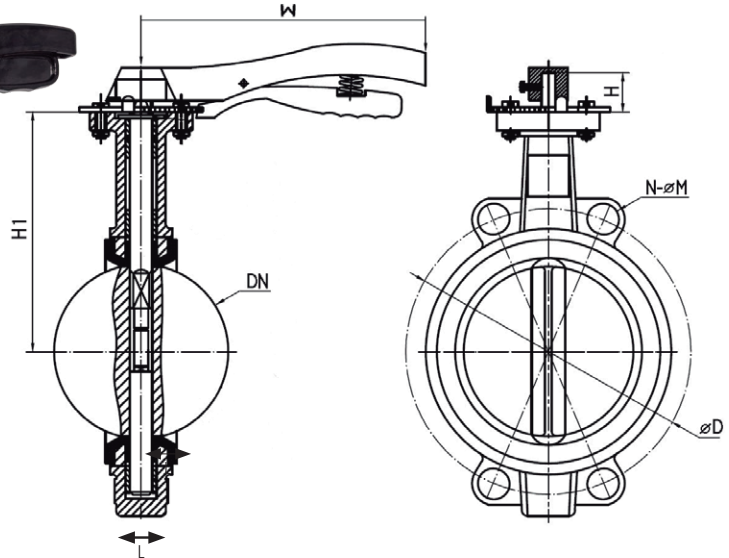

- Fabricado en fundición gris DN50-DN150 GGG25 y fundición dúctil >DN200 GGG-40
Made of cast iron DN25-DN150 GGG25 and ductile iron >DN200 GGG-40
- Recubrimiento en pintura Epoxy RAL5013
Epoxy coating Epoxy RAL5013
- Disco cromado fundición dúctil EN-GJS-400
Chromed ductile iron EN-GJS-400
- Material asiento: EPDM
Seat gasket material: EPDM
- Diseño s/ EN-12334, DIN 3202, EN 558-1
Design according to EN-12334, DIN 3202, EN 558-1
- Bridas s/ UNE EN-1092-2 PN10-PN16 Ansi B16.5 Clase 125/150
Flanges according to UNE EN-1092-2 PN10-PN16 Ansi B16.5 Class 125/150
- Presión máxima de trabajo:
2"-12": 16 Bar (250PSI)
Working pressure (Max):
2"-12": 16 Bar (250PSI)
- Temperatura de trabajo: -20°C / 120°C
Working temperature: -20°C / 120°C

DIMENSIONES / DIMENSIONS

CÓDIGO CODE	MEDIDA DN DN SIZE	DN	L	H	H1	W	Bridas / Flanges (EN-1092)									€
							PN 10			PN 16			ANSI 125/150			
							ØD	N-ØM	ø°	ØD	N-ØM	ø°	ØD	N-ØM	ø°	
5115-040	1 1/2"	40	-	-	-	-	-	-	-	-	-	-	-	-	-	52,93
5115-050	2"	50	43	25	131	170	125	4-M16	90	125	4-M16	90	120,6	4-19	90	46,10
5115-065	2 1/2"	65	46	25	142	170	145	4-M16	90	145	4-M16	90	139,7	4-19	90	52,65
5115-080	3"	80	46	25	150	170	160	4-M16	45	160	4-M16	45	152,4	4-19	90	57,95
5115-100	4"	100	52	28	170	215	180	4-M16	45	180	4-M16	45	190,5	4-19	45	82,43
5115-125	5"	125	56	28	185	215	210	4-M16	45	210	4-M16	45	215,9	4-22,4	45	116,31
5115-150	6"	150	56	28	205	215	240	4-M20	45	240	4-M20	45	241,3	4-22,4	45	123,99
5115-200	8"	200	60	30	240	265	295	4-M20	45	295	4-M20	30	298,4	4-22,4	45	210,76
5115-250	10"	250	68	35	270	350	350	4-M20	30	355	4-M24	30	361,9	4-25,4	30	289,22
5115-300*	12"	300	78	38	310	350	400	4-M20	30	410	4-M24	30	431,8	4-25,4	30	396,62

*Disponible hasta agotar existencias
*While stocks lasts

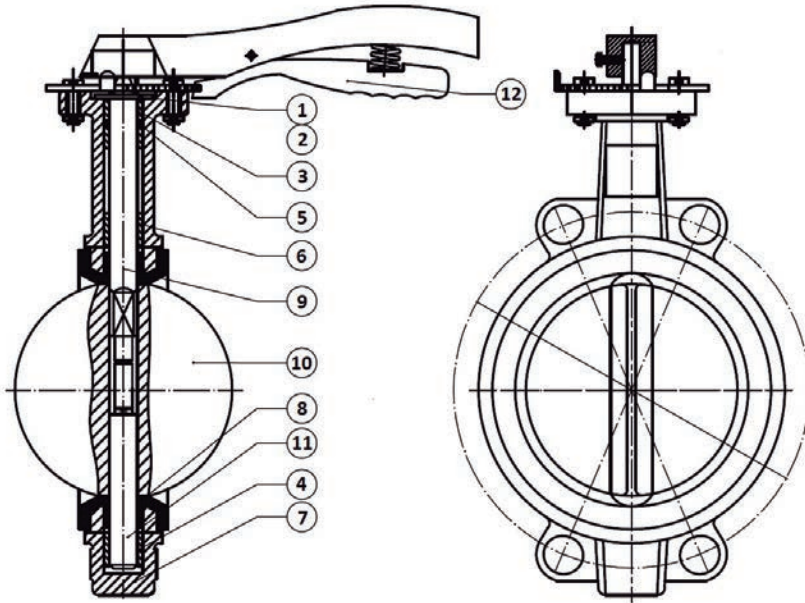

MATERIALES / MATERIALS

Nº	NOMBRE	MATERIALES	CALIDAD
Nº	NAME	MATERIALS	QUALITY
1	Cir clip Cir clip	Acero al carbono Galvanizado Galvanized carbon steel	65M
2	Anillo plano Flat gasket	Acero al Carbono Carbon steel	65M
3	Arandela presión Clamp spring	Acero Inoxidable Stainless steel	S201
4	Casquillo corto Short bushing	PTFE Reforzado Reinforced PTFE	PTFE + 15% Fiber Glass
5	Junta tórica O-Ring	EPDM	Shore 70
6	Cojinete largo Long bushing	PTFE Reforzado Reinforced PTFE	PTFE + 15% Fiber Glass
7	Cuerpo Body	Fundición DN50-200 F.Ductil >DN200 Cast iron DN50-200 Ductile Iron > Dn200	GG25 – GGG40
8	Asiento Seat	EPDM	Shore 70
9	Eje superior Upper shaft	Acero al carbono Galvanizado Galvanized carbon steel	C45
10	Disco Disc	Fundición Crom Chromed ductile Iron	Chromed GGG40
11	Eje inferior Lower shaft	Acero al carbono Galvanizado Galvanized carbon steel	C45
12	Maneta Lever	Aluminio Aluminium	

5115MR VÁLVULA MARIPOSA TIPO WAFER DISCO CROMADO CON REDUCTOR MANUAL

BUTTERFLY VALVE WAFER TYPE CHROMED DISC WITH GEAR OPERATOR

ECO

NUEVO
NEW

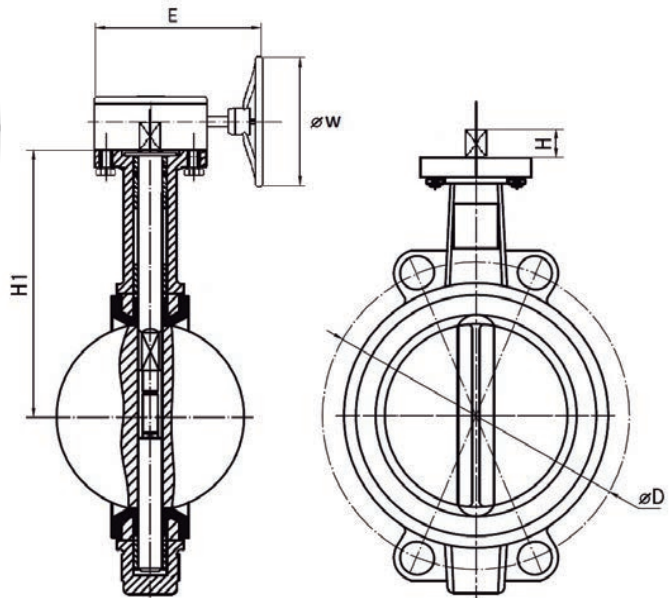

- Fabricado en fundición gris DN50-DN150 GG-25 y fundición dúctil >DN200 GGG-40
Made of cast iron DN25-DN150 GG-25 and ductile iron >DN200 GGG-40
- Recubrimiento en pintura epoxy RAL5013
Epoxy coating epoxy RAL5013
- Disco cromado fundición dúctil EN-GJS-400
Chromed ductile iron EN-GJS-400
- Material asiento: EPDM
Seat gasket material: EPDM
- Diseño s/ EN-12334, DIN 3202, EN 558-1
Design according to EN-12334, DIN 3202, EN 558-1
- Bridas s/ UNE EN-1092-2 PN10-PN16 Ansi B16.5 Clase 125/150
Flanges according to UNE EN-1092-2 PN10-PN16 Ansi B16.5 Class 125/150
- Presión máxima de trabajo:
2"-12": 16 Bar (250PSI)
14"-24": 10 Bar (150PSI)
Working pressure (Max):
2"-12": 16 Bar (250PSI)
14"-24": 10 Bar (150PSI)
- Temperatura de trabajo: -20°C / 120°C
Working temperature: -20°C / 120°C

DIMENSIONES / DIMENSIONS

CÓDIGO CODE	MEDIDA DN DN SIZE	DN	H	H1	E	DIN 2576 - PN 10			DIN 2502 - PN 16			ANSI 125/150			€	
						ØW	ØD	N-ØM	Ø°	ØD	N-ØM	Ø°	ØD	N-ØM		Ø°
5115-050MR	2"	50	25	131	105	160	125	4-M16	90	125	4-M16	90	120,6	4-19	90	98,57
5115-065MR	2 1/2"	65	25	142	165	160	145	4-M16	90	145	4-M16	90	139,7	4-19	90	104,13
5115-080MR	3"	80	25	150	165	160	160	4-M16	45	160	4-M16	45	152,4	4-19	90	107,69
5115-100MR	4"	100	25	170	165	160	180	4-M16	45	180	4-M16	45	190,5	4-19	45	132,13
5115-125MR	5"	125	25	184	165	160	210	4-M16	45	210	4-M16	45	215,9	4-22,4	45	166,01
5115-150MR	6"	150	25	200	165	160	240	4-M20	45	240	4-M20	45	241,3	4-22,4	45	173,79
5115-200MR	8"	200	35	240	165	265	295	4-M20	45	295	4-M20	30	298,4	4-2 2,4	45	323,26
5115-250MR	10"	250	35	270	240	265	350	4- M20	30	355	4-M24	30	361,9	4-25,4	30	365,44
5115-300MR	12"	300	35	310	240	265	400	4- M20	30	355	4-M24	30	431,8	4-25,4	30	535,25
5115-350MR	14"	350	45	368	-	-	460	4-M20	22,5	470	4-M24	22,5	476,3	4-28,5	30	658,13
5115-400MR	16"	400	50	400	-	-	515	4-M24	22,5	525	4-M27	22,5	539,8	4-31,8	22,5	1.354,48
5115-500MR	20"	500	55	480	-	-	620	4-M24	18	650	4-M30	18	635	4-31,8	18	2.286,84
5115-600MR	24"	600	68	562	-	-	725	4-M27	18	770	4-M33	18	749,3	4-44,5	18	3.220,54

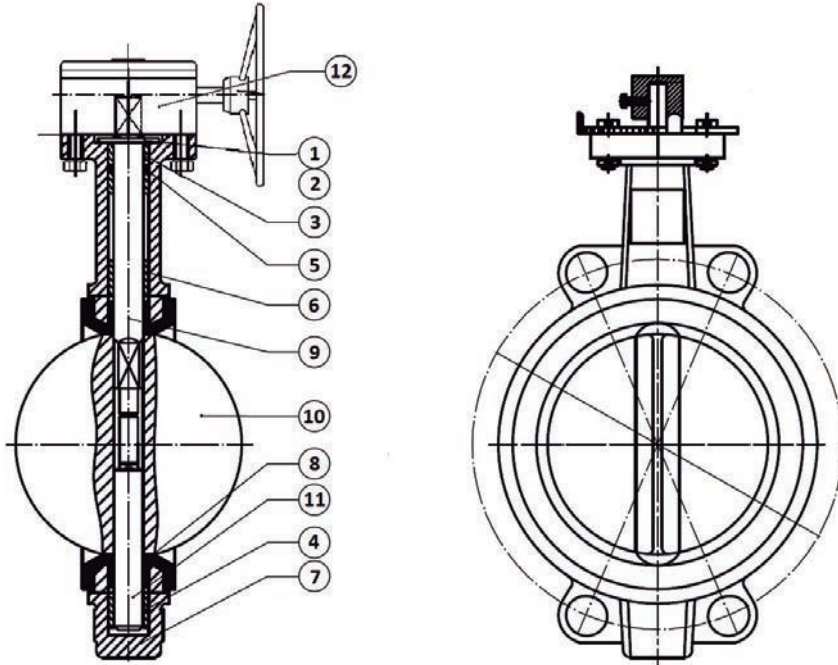

MATERIALES / MATERIALS

Nº	NOMBRE	MATERIALES	CALIDAD
Nº	NAME	MATERIALS	QUALITY
1	Cir clip Cir clip	Acero al carbono galvanizado Galvanized carbon steel	65M
2	Anillo plano Flat gasket	Acero inoxidable Stainless steel	S201
3	Arandela presión Clamp spring	Acero inoxidable Stainless steel	S201
4	Casquillo corto Short bushing	PTFE reforzado Reinforced PTFE	PTFE + 15% Fiber Glass
5	Junta tórica O-Ring	EPDM	Shore 70
6	Cojinete largo Long bushing	PTFE reforzado Reinforced PTFE	PTFE + 15% Fiber Glass
7	Cuerpo Body	Fundición DN50-200 Fundición Ductil >DN200 Cast iron DN50-200 Ductile Iron > Dn200	GG25 – GGG40
8	Asiento Seat	EPDM	Shore 70
9	Eje superior Upper shaft	Acero al carbono galvanizado Galvanized carbon steel	C45
10	Disco Disc	Fundición crom Chromed ductile iron	Chromed GGG40
11	Eje inferior Lower shaft	Acero al carbono galvanizado Galvanized carbon steel	C45
12	Reductor Manual Gear box	Fundición Cast iron	GG25

51143

VÁLVULA DE MARIPOSA TIPO WAFER DISCO Y ASIENTO PTFE
BUTTERFLY VALVE WAFER TYPE PTFE DISC AND SEAT

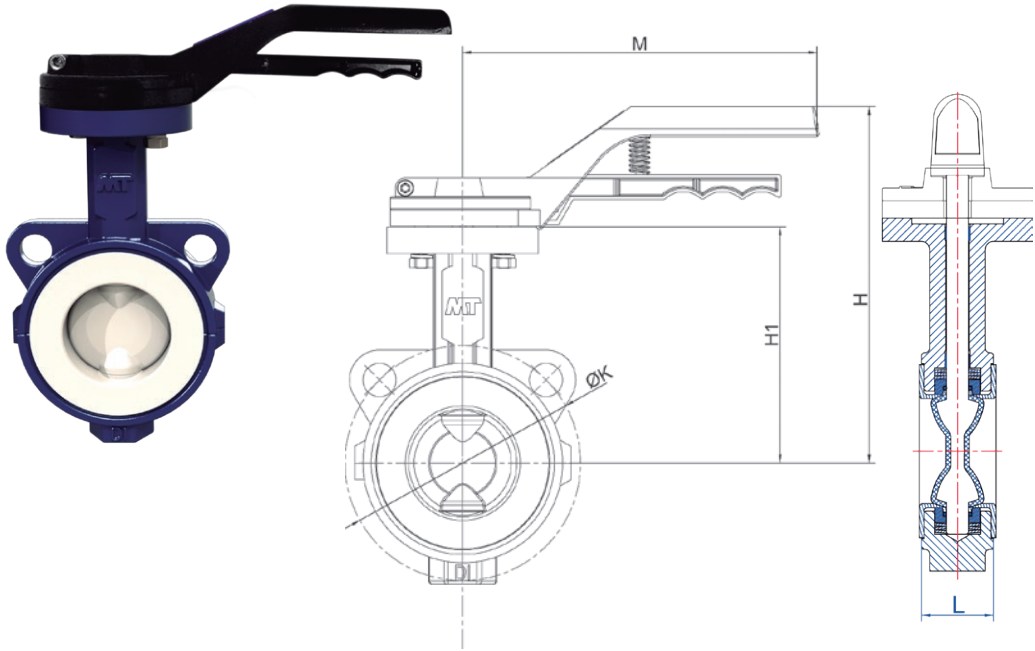

- Fabricado en fundición dúctil GGG-40 (GJS-400)
Made of ductile iron GGG-40 (GJS-400)
- Recubrimiento en pintura RAL5013 Epoxy
Epoxy coating RAL5013
- Disco acero inoxidable 316 + PTFE
Stainless steel disc 316 + PTFE
- Asiento PTFE
PTFE seat gasket

- Bridas s/ UNE EN1092-2 PN10-PN16
ANSI B16.5 Clase 125/150
Flanges according to UNE EN1092-2 PN10
ANSI B16.1 Class 125/150 PN16
- Presión máxima de trabajo: 16 Bar DN200 PN10
Working pressure (Max): 16 Bar DN200 PN10
- Temperatura de trabajo: -20°C / 180°C
Working temperature: -20°C / 180°C

DIMENSIONES / DIMENSIONS

CÓDIGO	MEDIDA DN	DN	PN	L	H	H1	ØK	M	ISO 5211						€	
CODE	DN SIZE	DN	PN	L	H	H1	PN10	PN16	ANSI150	M	F	ØE	ØD	SxS	TORQUE	€
51143-050	2"	50	16	43	200	136	125	125	120,6	210	F07	70	90	11x11	24	401,52
51143-065	2 1/2"	65	16	46	205	140	145	145	139,7	210	F07	70	90	11x11	24	439,04
51143-080	3"	80	16	46	205	140	160	160	152,4	210	F07	70	90	11x11	38	601,97
51143-100	4"	100	16	52	224	158	180	180	190,5	210	F07	70	90	14x14	56	810,84
51143-125	5"	120	16	56	235	170	210	210	215,9	210	F07	70	90	17x17	95	974,52
51143-150MR	6"	150	16	56	-	190	240	240	241,3	-	F07	70	90	17x17	142	1.212,95
51143-200MR	8"	200	10	60	-	232	295	295	298,4	-	F10	102	125	22x22	250	2.169,81

- Reductor manual para 6" y 8"
Manual reducer for 6" and 8"

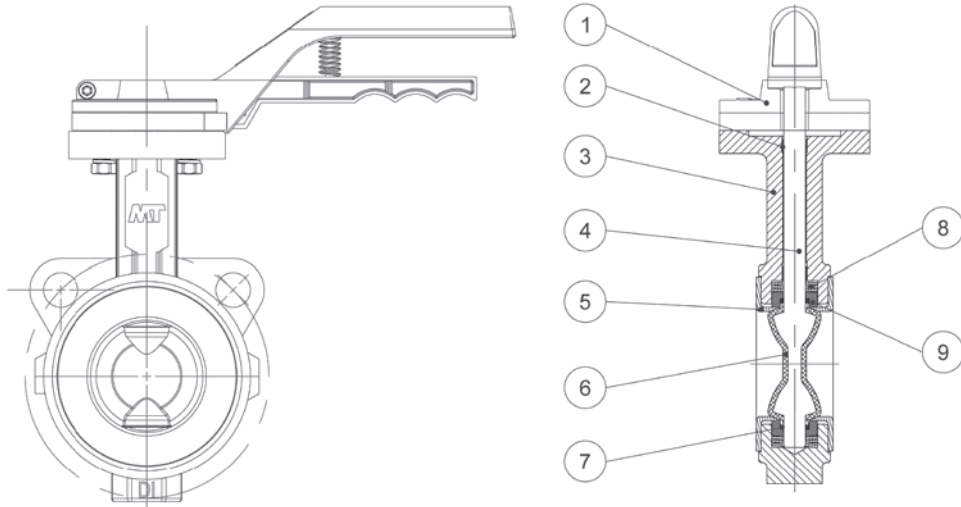

MATERIALES / MATERIALS

Nº	NOMBRE	MATERIALES	CALIDAD
Nº	NAME	MATERIALS	QUALITY
1	Maneta Handle	Aluminio Aluminium	-
2	Casquillo centrador Positioning sleeve	INOX. + PTFE S.S. + PTFE	AISI-304 + PTFE
3	Cuerpo Body	Fundición Ductil iron	GGG40
4	Eje Stem	Acero inoxidable Stainless steel	AISI-420
5	Asiento Seat	PTFE	PTFE
6	Disco Disc	INOX + PTFE S.S. + PTFE	AISI-316 + PTFE
7	Junta tórica O-ring	FKM	FKM
8	Empaquetadura eje Stem packing	Acero al carbono Carbon steel	65Mn
9	Prensaestopa Packing gland	Acero inoxidable Stainless steel	AISI-316

5144

5144MR

VÁLVULA DE MARIPOSA TIPO LUG DISCO INOX. ASIENTO BLANDO NBR
BUTTERFLY VALVE LUG TYPE STAINLESS STEEL DISC NBR SOFT SEAT

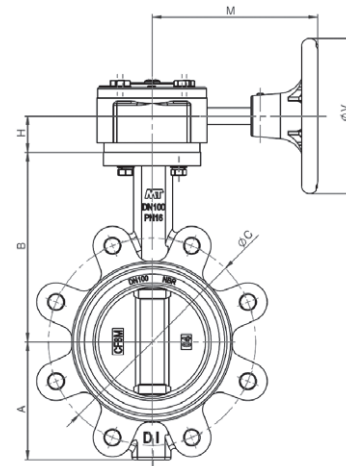
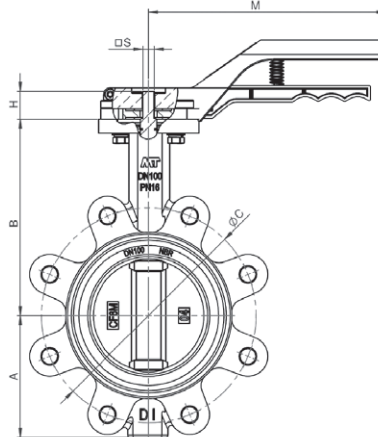

- Fabricado en fundición ductil GGG-40
Made of ductile iron GGG-40
- Recubrimiento en pintura Epoxy RAL5013
Epoxy coating RAL5013
- Disco acero inoxidable AISI-316
Stainless steel disc AISI-316
- Asiento en elastómero NBR
NBR seat gasket
- Fabricado bajo normativa: EN-1092-2 PN16
Manufactured according to standards: EN-1092-2 PN16
- Presión máxima de trabajo: 16 Bar: 2" - 6" / 10 Bar: 8" - 12"
Working pressure (Max): 16 Bar: 2" - 6" / 10 Bar: 8" - 12"
- Temperatura de trabajo: -20°C / 80°C
Working temperature: -20°C / 80°C

5144 MANETA PALANCA / HAND LEVER

DIMENSIONES / DIMENSIONS

CÓDIGO	MEDIDA DN	DN	A	B	H	□S	ANCHO	ØC	ØC	M	€
CODE	DN SIZE	DN	A	B	H	□S	WIDTH	PN10/16	ANSI 125/150	M	€
5144-050	2"	50	62	141	25	11	43	125	120,6	210	68,62
5144-065	2 ½"	65	72	153	25	11	46	145	139,7	210	79,43
5144-080	3"	80	87	161	25	11	46	160	152,4	210	102,86
5144-100	4"	100	106	178	25	11	52	180	190,5	210	133,31
5144-125	5"	125	123	193	25	14	56	210	215,9	210	186,53
5144-150	6"	150	138	204	25	14	56	240	241,3	210	212,02
5144-200	8"	200	173	247	35	17	60	295	298,4	340	383,50

5144MR REDUCTOR MANUAL / GEAR OPERATOR
DIMENSIONES / DIMENSIONS

CÓDIGO	MEDIDA	DN	A	B	H	ØV	M	ANCHO	ØC	ØC	€
CODE	SIZE	DN	A	B	H	ØV	M	WIDTH	PN10/16	ANSI 125/150	€
5144-050MR	2"	50	62	141	25	145	160	43	125	120,6	121,10
5144-065MR	2 ½"	65	72	153	25	145	160	46	145	139,7	131,90
5144-080MR	3"	80	87	161	25	145	160	46	160	152,4	155,33
5144-100MR	4"	100	106	178	25	145	160	52	180	190,5	185,78
5144-125MR	5"	125	123	193	25	145	160	56	210	215,9	239,00
5144-150MR	6"	150	138	204	25	145	160	56	240	241,3	264,50
5144-200MR	8"	200	173	247	35	300	240	60	295	298,4	478,64
5144-250MR	10"	250	212	277	35	300	240	68	350 / 355	361,9	628,34
5144-300MR	12"	300	253	324	45	300	240	78	400 / 410	431,8	919,28

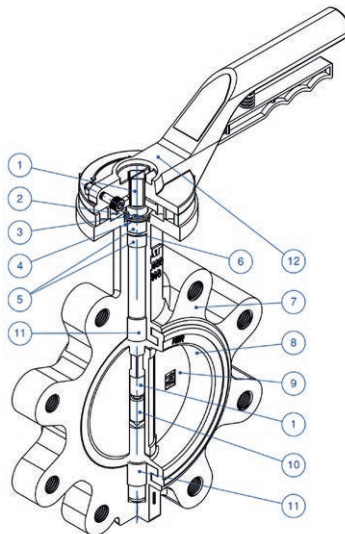

MATERIALES / MATERIALS

Nº	NOMBRE	MATERIALES	CALIDAD
Nº	NAME	MATERIALS	QUALITY
1	Eje superior Upper stem	Acero Inoxidable Stainless steel	ASTM A420
2	Anillo elástico Cir clip	Acero para muelles Spring steel	ASTM A29M
3	Arandela plana Flat gasket	Acero al Carbono Carbon Steel	Q235
4	Arandela curva Clam spring	Acero para muelles Spring steel	ASTM A29M
5	Casquillo Bushing	PTFE + FG	PTFE +FG
6	Junta tórica O-Ring	NBR	NBR
7	Cuerpo Body	Fundición Ductil Ductile Iron	GGG40
8	Asiento del disco Disc seat	5114 EPDM / 51142 NBR	EPDM Shore 70 / NBR Shore 70
9	Disco Disc	Acero Inoxidable Stainless steel	ASTM A276 AISI 316 EN1.4401
10	Eje inferior Lower stem	Acero Inoxidable Stainless steel	ASTM A420
11	Casquillo Bushing	PTFE + FG	PTFE +FG
12	Maneta Lever Reductor Manual Gear Box	Aluminio Aluminium Fundición Cast Iron	Aluminium GG25

51224

RECAMBIO - REDUCTOR MANUAL PARA LAS VÁLVULAS DE MARIPOSA
 SPARE PART - HAND WHEEL GEAR BOX FOR BUTTERFLY VALVES



CÓDIGO	DN		€
CODE	DN		€
51224-050080	2"-3"	1	65,35
51224-100	4"	1	65,35
51224-125150	5"-6"	1	65,35
51224-200	8"	1	131,51
51224-250	10"	1	131,51
51224-300	12"	1	152,25

VÁLVULAS INDUSTRIALES AUTOMATISMOS

INDUSTRIAL VALVES AUTOMATISMS



SERVICIO INTEGRAL DE MONTAJE Y ENTREGA INMEDIATA EN 24 HORAS

En MT no nos gustan las sorpresas y los problemas derivados de un mal montaje de nuestros productos. Es por este motivo, que disponemos de personal técnico especializado para adaptar el automatismo correcto en cada una de nuestras válvulas y las probamos antes de mandar al cliente. Con ello garantizamos un correcto funcionamiento de nuestras válvulas actuadas y ofrecemos un servicio rápido de montaje y entrega en un tiempo récord. MT, buscando siempre la mejor solución para nuestro cliente.

INTEGRAL ASSEMBLY SERVICE AND IMMEDIATE DELIVERY IN 24 HOURS

In MT we don't like the surprises and the problems derived from a bad assembly of our products. For this reason, we have specialized technical personnel to adapt the correct automation in each of our valves and test them before sending the customer. With this we guarantee the correct functioning of our actuated valves and we offer a fast service of assembly and delivery in a record time. MT, always looking for the best solution for our client.



VAL. IND. AUTOMATISMOS IND. VAL. AUTOMATISMS



LEYENDA DE ICONOS ICON KEY

Posibles codificaciones
aplicadas en esta sección.

Possible encodings applied
in this section.



ATEX

CERTIFICADOS DE PRODUCTO
PRODUCT CERTIFICATES



Recambios
Spare parts

PROPIEDADES DE PRODUCTO
PRODUCT PROPERTIES

ACTUADORES NEUMÁTICOS

PNEUMATIC ACTUATORS

5100



ACTUADOR NEUMÁTICO SIMPLE EFECTO
PNEUMATIC SIMPLE RETURN ACTUATOR



CÓDIGO	4BAR	6BAR	8BAR	MUELLE FINAL	ISO 5211	s	€
CODE	4BAR	6BAR	8BAR	FINAL DOC	ISO 5211	s	€
5100-052	3,6	11,6	-	8,5	F03-F05	11	105,88
5100-063	8,2	22,8	37,4	13,5	F05-F07	11	133,90
5100-075	11	31,2	51,2	21,1	F05-F07	14	160,36
5100-083	16,6	48	79,3	31,6	F05-F07	17	185,28
5100-092	21,5	66,7	111,8	46,7	F05-F07	17	241,32
5100-105	33,4	99,6	165,7	63,3	F07-F10	17	291,14
5100-125	44	144	245	105	F07-F10	22	390,78
5100-140	84	255	426	172	F10-F12	27	576,06
5100-160	115	381	647	279	F10-F12	27	834,52
5100-190	233	658	1084	400	F14	27	1.258,00
5100-210	304	836	1368	550	F14	36	1.535,12
5100-240	431	1201	1970	821	F16	36	2.460,00
5100-270	767	1937	3107	1119	F16	46	3.705,48

5200



ACTUADOR NEUMÁTICO DOBLE EFECTO
PNEUMATIC DOUBLE ACTING ACTUATOR



CÓDIGO	4BAR	6BAR	8BAR	ISO 5211	s	€
CODE	4BAR	6BAR	8BAR	ISO 5211	s	€
5200-052	16	24	32	F03-F05	11	75,67
5200-063	29	44	58	F05-F07	11	90,30
5200-075	40	60	80	F05-F07	14	137,00
5200-083	63	94	125	F05-F07	17	149,46
5200-092	90	135	180	F05-F07	17	199,28
5200-105	132	198	264	F07-F10	17	239,76
5200-125	200	301	401	F07-F10	22	330,06
5200-140	342	513	684	F10-F12	27	420,36
5200-160	532	798	1094	F10-F12	27	597,86
5200-190	851	1277	1702	F14	27	993,32
5200-210	1094	1596	2128	F14	36	1.201,94
5200-240	1539	2308	3078	F16	36	2.008,15
5200-270	2339	3508	4677	F16	46	3.107,62

540052

ELECTROVÁLVULAS NORMATIVA NAMUR 5/2 VÍAS
SERIES NAMUR TYPE 5/2 WAYS SOLENOID VALVE



540032

ELECTROVÁLVULAS NORMATIVA NAMUR 3/2 VÍAS
SERIES NAMUR TYPE 3/2 WAYS SOLENOID VALVE

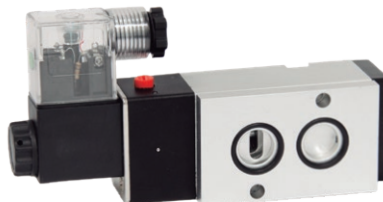

CÓDIGO	VOLTAJE	€
CODE	VOLTAGE	€
540052-01	DC24V	42,65
540052-02	AC24V-DC12V	42,65
540052-03	AC110V	42,65
540052-04	AC220V	42,65

- Utilizada para actuadores doble efecto, salvo excepciones
Doble acting actuators used, with exceptions

CÓDIGO	VOLTAJE	€
CODE	VOLTAGE	€
540032-01	DC24V	50,60
540032-02	AC24V-DC12V	50,60
540032-03	AC110V	50,60
540032-04	AC220V	50,60

- Utilizada para actuadores simple efecto, salvo excepciones
Simple acting actuators used, with exceptions

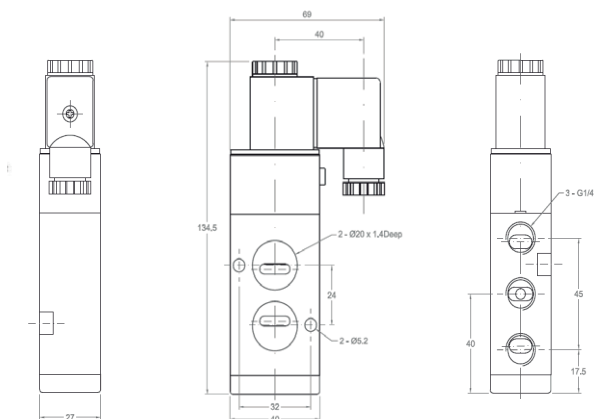

CÓDIGO	ESQUEMA	MATERIAL CUERPO	MATERIAL JUNTA	NÚMERO POSICIÓN	VOLTAGE BOBINA	TAMAÑO PUERTO	CONECTOR DISPONIBLE	CONSUMO
CODE	DIAGRAM	BODY MATERIAL	SEALS MATERIAL	POSITION NUMBER	COLL VOLTAGE	PORT SIZE	AVAILABLE CONNECTOR	POWER CONSUMPTION

540052		Aluminio anodizado Anonized aluminium	NBR	5 Position 2 ways	DC12V DC24V AC24V	1/4"	With led	AC 4.5VA DC: 3W
540032				3 Position 2 ways	DC110V AC110V AC220V		-	

51SMC

POSICIONADOR PARA ACTUADOR NEUMÁTICO 4/20MA-0/10V
PNEUMATIC ELECTRIC ACTUATOR POSITIONER 4/20MA-0/10V



CÓDIGO	€
CODE	€
51SMC	Consultar

- Especificar el tipo de señal en el pedido 4-20mA o 0-10V
Specify signal input 4-20mA or 0-20 in the order.

51CFC

CAJA FINAL DE CARRERA
END MICROBOX



CÓDIGO	€
CODE	€
51CFC	46,26

- Caja polipropileno + 15% fibra de vidrio
Polypropilene + 15% fiber glass box
- Soporte acero + epoxi para condiciones ambientales extremas como opción en soporte inoxidable.
Steel + epoxy brackets stainless steel for extreme weather optional.
- Unión soporte Namur
Univeral Namur
- 2 micros mecánicos
2 mechanical switches

ACTUADORES ELÉCTRICOS

ELECTRIC ACTUATORS

5300 / 5324

ACTUADOR ELÉCTRICO
ELECTRIC ACTUATOR

CÓDIGO	PAR NM	VOLTAJE	ISO 5211	s
CODE	PAR NM	VOLTAGE	ISO 5211	s
5300-010 / 5324-010	10	85v-240v / 24v	F03-F04-F05	9-11-14
5300-020 / 5324-020	20	24v-240v / 12v	F03-F04-F05	9-11-14
5300-035 / 5324-035	35	24v-240v / 12v	F03-F04-F05	9-11-14
5300-055 / 5324-055	55	24v-240v / 12v	F05-F07	11-14-17
5300-085 / 5324-085	85	24v-240v / 12v	F05-F07	11-14-17
5300-140 / 5324-140	140	24v-240v / 12v	F07-F10	17-22
5300-300 / 5324-300	300	24v-240v / 12v	F07-F10	17-22

CÓDIGO	VOLTAJE	€
CODE	VOLTAGE	€
5300-010	85v-240v VAC/VDC	202,40
5300-020	24v-240v VAC/VDC	274,02
5300-035	24v-240v VAC/VDC	373,66
5300-055	24v-240v VAC/VDC	451,50
5300-085	24v-240v VAC/VDC	576,06
5300-140	24v-240v VAC/VDC	747,32
5300-300	24v-240v VAC/VDC	809,60

CÓDIGO	VOLTAJE	€
CODE	VOLTAGE	€
5324-010	24v VAC/VDC	202,40
5324-020	12v VAC/VDC	274,02
5324-035	12v VAC/VDC	373,66
5324-055	12v VAC/VDC	451,50
5324-085	12v VAC/VDC	576,06
5324-140	12v VAC/VDC	747,32
5324-300	12v VAC/VDC	809,60



51DPS

KIT POSICIONADOR PARA ACTUADOR ELÉCTRICO 4/20MA-0/10V
ELECTRIC ACTUATOR POSITIONER KIT 4/20MA-0/10V

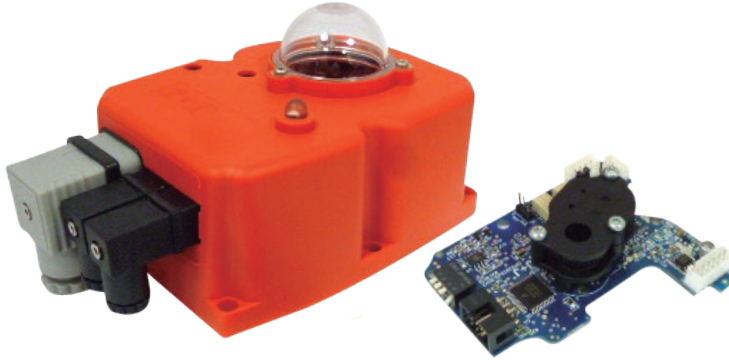

CÓDIGO	€
CODE	€
51DPS01*	252,22
51DPS02**	470,20

- Especificar el tipo de señal en el pedido 4-20mA ó 0-10V
Specify signal input 4-20mA or 0-10V before order

* Para actuadores eléctricos 20/35/55/85

* For electric actuators 20/35/55/85

**Para actuadores eléctricos 140/300

**For electric actuators 140/300

51BSR

KIT BLOQUE DE SEGURIDAD PARA ACTUADOR ELÉCTRICO
SAFETY LOCK ELECTRIC ACTUATOR KIT

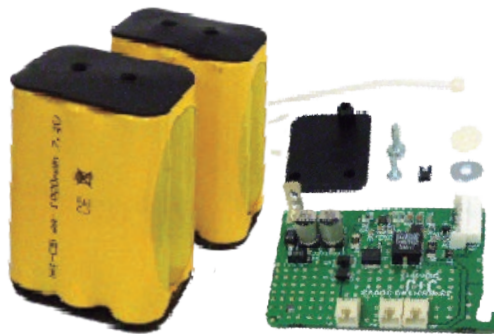

CÓDIGO	€
CODE	€
51BSR01*	264,68
51BSR02**	373,66

- El actuador gira a su posición predeterminada en caso de falta de tensión
Actuator goes to initial position in case no voltage

* Para actuadores eléctricos 20/35/55/85

* For electric actuators 20/35/55/85

**Para actuadores eléctricos 140/300

**For electric actuators 140/300

DATOS TÉCNICOS ISO 5211

ISO 5211 DATA SHEET

ISO 5211

BRIDA	PAR MÁX. N·m	D	D (K)	SXS	n
FLANGE	MAX. TORQUE N·m	D	D (K)	SXS	n
F03	32	46	M5	9	4
F04	63	54	M5	9 - 11	4
F05	125	65	M6	9 - 14	4
F07	250	90	M8	11 - 17	4
F10	500	125	M10	14 - 22	4
F12	1.000	150	M12	17 - 27	4
F14	2.000	175	M16	22 - 36	4
F16	4.000	210	M20	27 - 46	8
F25	8.000	300	M16	36 - 55	8
F30	16.000	350	M20	46 - 75	8
F35	32.000	415	M30	-	8
F40	63.000	475	M36	-	8
F48	125.000	560	M36	-	12
F60	250.000	686	M36	-	20

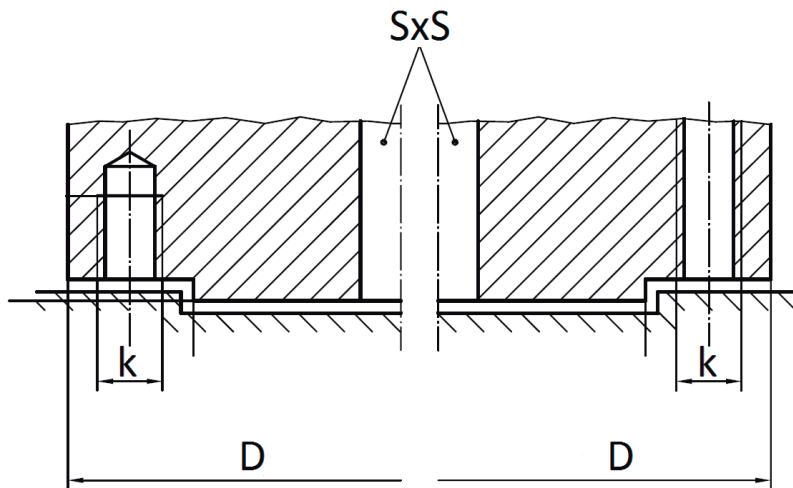

5114

VÁLVULA DE MARIPOSA TIPO WAFER DISCO INOXIDABLE ASIENTO BLANDO EPDM
CON ACTUADOR / BUTTERFLY VALVE WAFER TYPE STAINLESS STEEL DISC EPDM
SOFT SEAT WITH ACTUATOR

SIMPLE EFECTO SIMPLE RETURN ACTUATOR



CÓDIGO	ACTUADOR	H	F	A	G	MEDIDA	€
CODE	ACTUATOR	H	F	A	G	SIZE	€
5105114-050	5100075	276	120	201	94	2"	266,41
5105114-065	5100075	288	120	201	94	2 1/2"	273,28
5105114-080	5100083	304	128	209	101	3"	319,21
5105114-100	5100083	321	128	209	101	4"	337,43
5105114-125	5100125	383	175	332	138	5"	628,69
5105114-150	5100125	394	175	332	138	6"	646,82
5105114-200	5100160	484	217	450	174	8"	1.483,30
5105114-250	5100160	514	217	450	174	10"	1.635,25
5105114-300	5100190	627	260	507	206	12"	2.289,88

- Actuadores neumáticos ATEX
Pneumatic actuators ATEX
- Los actuadores neumáticos están calculados en base a una presión de aire de entrada de 6 Bares
Pneumatic actuators are calculated based on a inlet air pressure of 6 Bar

DOBLE EFECTO DOUBLE ACTING ACTUATOR



CÓDIGO	ACTUADOR	H	F	A	G	MEDIDA	€
CODE	ACTUATOR	H	F	A	G	SIZE	€
5205114-050	5200052	248	92	145	71	2"	160,38
5205114-065	5200052	260	92	145	71	2 1/2"	167,24
5205114-080	5200063	284	108	169	82	3"	225,73
5205114-100	5200063	301	108	169	82	4"	248,01
5205114-125	5200083	336	128	209	101	5"	353,45
5205114-150	5200083	347	128	209	101	6"	362,25
5205114-200	5200105	420	153	275	122	8"	620,78
5205114-250	5200125	472	175	332	138	10"	853,64
5205114-300	5200140	559	192	385	153	12"	1.326,11

- Actuadores neumáticos ATEX
Pneumatic actuators ATEX
- Los actuadores neumáticos están calculados en base a una presión de aire de entrada de 6 Bares
Pneumatic actuators are calculated based on a inlet air pressure of 6 Bar

ACTUADOR ELÉCTRICO BAJO VOLTAJE ELECTRIC ACTUATOR LOW VOLTAGE



CÓDIGO	ACTUADOR	H	F	A	G	MEDIDA	€
CODE	ACTUATOR	H	F	A	G	SIZE	€
5325114-050	5324020	325	169	181	110	2"	365,61
5325114-065	5324035	337	169	181	110	2 1/2"	470,94
5325114-080	5324055	345	169	181	110	3"	582,28
5325114-100	5324055	389	196	181	110	4"	604,56
5325114-125	5324085	404	196	181	128	5"	781,36
5325114-150	5324140	458	254	235	214	6"	963,74
5325114-200	5324300	521	254	235	214	8"	1.220,22
5325114-250	5324300	551	254	235	214	10"	1.384,78

- 12V VAC/VDC

ACTUADOR ELÉCTRICO ALTO VOLTAJE ELECTRIC ACTUATOR HIGH VOLTAGE



CÓDIGO	ACTUADOR	H	F	A	G	MEDIDA	€
CODE	ACTUATOR	H	F	A	G	SIZE	€
5305114-050	5300020	325	169	181	110	2"	365,61
5305114-065	5324035	337	169	181	110	2 1/2"	470,94
5305114-080	5324055	345	169	181	110	3"	582,28
5305114-100	5300055	389	196	181	110	4"	604,56
5305114-125	5300085	404	196	181	128	5"	781,36
5305114-150	5300140	458	254	235	214	6"	963,74
5305114-200	5300300	521	254	235	214	8"	1.220,22
5305114-250	5300300	551	254	235	214	10"	1.384,78

- 24V-240V VAC/VDC

H ALTURA DESDE EJE DE VÁLVULA A LA PARTE SUPERIOR DEL ACTUADOR / HIGH FROM VALVE AXIS TO ACTUATOR TOP
F ALTURA DEL ACTUADOR / ACTUATOR HIGH
A LONGITUD DEL ACTUADOR / ACTUATOR LENGTH
G GROSOR DEL ACTUADOR / ACTUATOR THICKNESS

5115

VÁLVULA DE MARIPOSA TIPO WAFER DISCO CROMADO ASIENTO RÍGIDO EPDM CON ACTUADOR / BUTTERFLY VALVE WAFER TYPE CHROMED DISC EPDM HARD SEAT WITH ACTUATOR

SIMPLE EFECTO SIMPLE RETURN ACTUATOR



CÓDIGO	ACTUADOR	H	F	A	G	MEDIDA	€
CODE	ACTUATOR	H	F	A	G	SIZE	€
5105115-050	5100063	249	108	169	82	2"	203,56
5105115-065	5100075	272	120	201	94	2 1/2"	253,78
5105115-080	5100092	300	140	242	109	3"	363,11
5105115-100	5100092	325	140	242	109	4"	373,73
5105115-125	5100105	353	153	275	122	5"	469,74
5105115-150	5100125	380	175	332	138	6"	581,38
5105115-200	5100140	447	192	385	153	8"	900,74
5105115-250	5100140	482	192	385	153	10"	1.011,64
5105115-300	5100190	590	260	507	206	12"	1.989,73

- Actuadores neumáticos ATEX
Pneumatic actuators ATEX
- Los actuadores neumáticos están calculados en base a una presión de aire de entrada de 6 Bares
Pneumatic actuators are calculated based on a inlet air pressure of 6 Bar

DOBLE EFECTO DOUBLE ACTING ACTUATOR



CÓDIGO	ACTUADOR	H	F	A	G	MEDIDA	€
CODE	ACTUATOR	H	F	A	G	SIZE	€
5205115-050	5200052	233	92	145	71	2"	155,31
5205115-065	5200052	244	92	145	71	2 1/2"	162,40
5205115-080	5200063	268	108	169	82	3"	213,20
5205115-100	5200063	293	108	169	82	4"	217,18
5205115-125	5200075	320	120	201	94	5"	262,05
5205115-150	5200083	348	128	209	101	6"	286,43
5205115-200	5200105	408	153	275	122	8"	476,00
5205115-250	5200105	443	153	275	122	10"	583,33
5205115-300	5200125	505	175	332	138	12"	764,87

- Actuadores neumáticos ATEX
Pneumatic actuators ATEX
- Los actuadores neumáticos están calculados en base a una presión de aire de entrada de 6 Bares
Pneumatic actuators are calculated based on a inlet air pressure of 6 Bar

ACTUADOR ELÉCTRICO BAJO VOLTAJE ELECTRIC ACTUATOR LOW VOLTAGE



CÓDIGO CODE	ACTUADOR ACTUATOR	H H	F F	A A	G G	MEDIDA SIZE	€ €
5325115-050	5324020	310	169	181	110	2"	351,25
5325115-065	5324035	321	169	181	110	2 1/2"	456,80
5325115-080	5324055	356	196	181	110	3"	563,11
5325115-100	5324055	381	196	181	110	4"	573,73
5325115-125	5324085	396	196	181	128	5"	698,97
5325115-150	5324140	474	254	235	214	6"	889,51
5325115-200	5324300	514	254	235	214	8"	1.076,90
5325115-250	5324300	544	254	235	214	10"	1.141,24

- 12V VAC/VDC

ACTUADOR ELÉCTRICO ALTO VOLTAJE ELECTRIC ACTUATOR HIGH VOLTAGE



CÓDIGO CODE	ACTUADOR ACTUATOR	H H	F F	A A	G G	MEDIDA SIZE	€ €
5305115-050	5300020	310	169	181	110	2"	351,25
5305115-065	5300035	321	169	181	110	2 1/2"	456,80
5305115-080	5300055	356	196	181	110	3"	563,11
5305115-100	5300055	381	196	181	110	4"	573,73
5305115-125	5300085	396	196	181	128	5"	698,97
5305115-150	5300140	474	254	235	214	6"	889,51
5305115-200	5300300	514	254	235	214	8"	1.076,90
5305115-250	5300300	544	254	235	214	10"	1.141,24

- 24V-240V VAC/VDC

H ALTURA DESDE EJE DE VÁLVULA A LA PARTE SUPERIOR DEL ACTUADOR / HIGH FROM VALVE AXIS TO ACTUATOR TOP
F ALTURA DEL ACTUADOR / ACTUATOR HIGH
A LONGITUD DEL ACTUADOR / ACTUATOR LENGTH
G GROSOR DEL ACTUADOR / ACTUATOR THICKNESS

51151

VÁLVULA DE MARIPOSA TIPO WAFER DISCO INOXIDABLE ASIENTO RÍGIDO EPDM-
CON ACTUADOR / BUTTERFLY VALVE WAFER TYPE STAINLESS STEEL DISC EPDM
HARD SEAT WITH ACTUATOR

SIMPLE EFECTO
SIMPLE RETURN ACTUATOR



CÓDIGO	ACTUADOR	H	F	A	G	MEDIDA	€
CODE	ACTUATOR	H	F	A	G	SIZE	€
51051151-050	5100075	261	120	201	94	2"	251,99
51051151-065	5100075	272	120	201	94	2 1/2"	261,03
51051151-080	5100092	300	140	242	108,5	3"	372,69
51051151-100	5100105	338	153	275	122	4"	473,60
51051151-125	5100105	353	153	275	122	5"	492,77
51051151-150	5100105	373	153	275	122	6"	515,37
51051151-200	5100140	451,5	191,5	385	153	8"	964,99
51051151-250	5100160	507	217	450	174	10"	1.449,87
51051151-300	5100190	590	260	507	206	12"	2.253,59

- Actuadores neumáticos ATEX
Pneumatic actuators ATEX
- Los actuadores neumáticos están calculados en base a una presión de aire de entrada de 6 Bares
Pneumatic actuators are calculated based on a inlet air pressure of 6 Bar

DOBLE EFECTO
DOUBLE ACTING ACTUATOR



CÓDIGO	ACTUADOR	H	F	A	G	MEDIDA	€
CODE	ACTUATOR	H	F	A	G	SIZE	€
52051151-050	5200052	233	92	145	71	2"	160,61
52051151-065	5200052	244	92	145	71	2 1/2"	169,65
52051151-080	5200075	280	120	201	94	3"	258,84
52051151-100	5200075	305	120	201	94	4"	275,63
52051151-125	5200075	320	120	201	94	5"	293,64
52051151-150	5200083	348	128	209	101	6"	338,45
52051151-200	5200105	408	153	275	122	8"	572,40
52051151-250	5200125	465	175	332	137,5	10"	834,20
52051151-300	5200140	521,5	191,5	385	153	12"	1.282,40

- Actuadores neumáticos ATEX
Pneumatic actuators ATEX
- Los actuadores neumáticos están calculados en base a una presión de aire de entrada de 6 Bares
Pneumatic actuators are calculated based on a inlet air pressure of 6 Bar

ACTUADOR ELÉCTRICO BAJO VOLTAJE ELECTRIC ACTUATOR LOW VOLTAGE



CÓDIGO CODE	ACTUADOR ACTUATOR	H H	F F	A A	G G	MEDIDA SIZE	€ €
53251151-050	5324020	310	169	181	110	2"	356,55
53251151-065	5324035	321	169	181	110	2 1/2"	464,05
53251151-080	5324055	356	196	181	110	3"	572,69
53251151-100	5324055	381	196	181	110	4"	589,48
53251151-125	5324085	396	196	181	128	5"	732,11
53251151-150	5324140	416	196	181	128	6"	913,83
53251151-200	5324300	514	254	235	214	8"	1.147,20
53251151-250	5324300	544	254	235	214	10"	1.323,18

- 12V VAC/VDC

ACTUADOR ELÉCTRICO ALTO VOLTAJE ELECTRIC ACTUATOR HIGH VOLTAGE



CÓDIGO CODE	ACTUADOR ACTUATOR	H H	F F	A A	G G	MEDIDA SIZE	€ €
53051151-050	5300020	310	169	181	110	2"	356,55
53051151-065	5300035	321	169	181	110	2 1/2"	464,05
53051151-080	5300055	356	196	181	110	3"	572,69
53051151-100	5300055	381	196	181	110	4"	589,48
53051151-125	5300085	396	196	181	128	5"	732,11
53051151-150	5324140	416	196	181	128	6"	913,83
53051151-200	5300300	514	254	235	214	8"	1.147,20
53051151-250	5300300	544	254	235	214	10"	1.323,18

- 24V-240V VAC/VDC

H ALTURA DESDE EJE DE VÁLVULA A LA PARTE SUPERIOR DEL ACTUADOR / HIGH FROM VALVE AXIS TO ACTUATOR TOP
F ALTURA DEL ACTUADOR / ACTUATOR HIGH
A LONGITUD DEL ACTUADOR / ACTUATOR LENGTH
G GROSOR DEL ACTUADOR / ACTUATOR THICKNESS

5140

VÁLVULA MARIPOSA TIPO WAFER EPDM DISCO POLIAMIDA 11 CON ACTUADOR
BUTTERFLY VALVE WAFER TYPE EPDM POLYAMIDE 11 DISC WITH ACTUATOR

SIMPLE EFECTO SIMPLE RETURN ACTUATOR



CÓDIGO	ACTUADOR	H	F	A	G	MEDIDA	€
CODE	ACTUATOR	H	F	A	G	SIZE	€
5105140-050	5100075	276	120	201	94	2"	262,42
5105140-065	5100075	288	120	201	94	2 1/2"	268,46
5105140-080	5100092	316	140	242	108,5	3"	376,76
5105140-100	5100105	346	153	275	122	4"	480,08
5105140-125	5100140	384,5	191,5	385	153	5"	804,93
5105140-150	5100140	395,5	191,5	385	153	6"	817,19
5105140-200	5100190	527	260	507	206	8"	1.797,61
5105140-250	5100190	557	260	507	206	10"	1.874,48

- Actuadores neumáticos ATEX
Pneumatic actuators ATEX
- Los actuadores neumáticos están calculados en base a una presión de aire de entrada de 6 Bares
Pneumatic actuators are calculated based on a inlet air pressure of 6 Bar

DOBLE EFECTO DOUBLE ACTING ACTUATOR



CÓDIGO	ACTUADOR	H	F	A	G	MEDIDA	€
CODE	ACTUATOR	H	F	A	G	SIZE	€
5205140-050	5200052	248	92	145	71	2"	156,88
5205140-065	5200052	260	92	145	71	2 1/2"	162,92
5205140-080	5200063	284	108	169	82	3"	220,21
5205140-100	5200075	313	120	201	94	4"	281,62
5205140-125	5200092	348	140	242	108,5	5"	359,24
5205140-150	5200092	344	140	242	108,5	6"	361,59
5205140-200	5200125	442	175	332	137,5	8"	649,31
5205140-250	5200125	472	175	332	137,5	10"	726,08

- Actuadores neumáticos ATEX
Pneumatic actuators ATEX
- Los actuadores neumáticos están calculados en base a una presión de aire de entrada de 6 Bares
Pneumatic actuators are calculated based on a inlet air pressure of 6 Bar

ACTUADOR ELÉCTRICO BAJO VOLTAJE ELECTRIC ACTUATOR LOW VOLTAGE



CÓDIGO	ACTUADOR	H	F	A	G	MEDIDA	€
CODE	ACTUATOR	H	F	A	G	SIZE	€
5325140-050	5324020	325	169	181	110	2"	362,11
5325140-065	5324035	337	169	181	110	2 1/2"	466,61
5325140-080	5324055	345	169	181	110	3"	560,82
5325140-100	5324055	389	196	181	110	4"	595,47
5325140-125	5324140	447	254	235	214	5"	900,35
5325140-150	5324140	458	254	235	214	6"	912,61
5325140-200	5324300	521	254	235	214	8"	1.125,06
5325140-250	-	-	-	-	-	10"	-

- 12V VAC/VDC

ACTUADOR ELÉCTRICO ALTO VOLTAJE ELECTRIC ACTUATOR HIGH VOLTAGE



CÓDIGO	ACTUADOR	H	F	A	G	MEDIDA	€
CODE	ACTUATOR	H	F	A	G	SIZE	€
5305140-050	5300020	325	169	181	110	2"	362,11
5305140-065	5324035	337	169	181	110	2 1/2"	466,61
5305140-080	5324055	345	169	181	110	3"	560,82
5305140-100	5300055	389	196	181	110	4"	595,47
5305140-125	5300140	447	254	235	214	5"	900,35
5305140-150	5300140	458	254	235	214	6"	912,61
5305140-200	5300300	521	254	235	214	8"	1.125,06
5305140-250	-	-	-	-	-	10"	-

- 24V-240V VAC/VDC

H ALTURA DESDE EJE DE VÁLVULA A LA PARTE SUPERIOR DEL ACTUADOR / HIGH FROM VALVE AXIS TO ACTUATOR TOP
F ALTURA DEL ACTUADOR / ACTUATOR HIGH
A LONGITUD DEL ACTUADOR / ACTUATOR LENGTH
G GROSOR DEL ACTUADOR / ACTUATOR THICKNESS

51142

VÁLVULA DE MARIPOSA TIPO WAFER DISCO INOXIDABLE ASIENTO BLANDO NBR
CON ACTUADOR / BUTTERFLY VALVE WAFER TYPE STAINLESS STEEL DISC NBR SOFT
SEAT WITH ACTUATOR

SIMPLE EFECTO SIMPLE RETURN ACTUATOR



CÓDIGO	ACTUADOR	H	F	A	G	MEDIDA	€
CODE	ACTUATOR	H	F	A	G	SIZE	€
51051142-050	5100075	276	120	201	94	2"	266,41
51051142-065	5100075	288	120	201	94	2 1/2"	273,26
51051142-080	5100083	304	128	209	101	3"	319,21
51051142-100	5100083	321	128	209	101	4"	337,43
51051142-125	5100125	383	175	332	137,5	5"	628,69
51051142-150	5100125	394	175	332	137,5	6"	646,82
51051142-200	5100160	484	217	450	174	8"	1.301,46
51051142-250	5100190	557	260	507	206	10"	2.092,41

- Actuadores neumáticos ATEX
Pneumatic actuators ATEX
- Los actuadores neumáticos están calculados en base a una presión de aire de entrada de 6 Bares
Pneumatic actuators are calculated based on a inlet air pressure of 6 Bar

DOBLE EFECTO DOUBLE ACTING ACTUATOR



CÓDIGO	ACTUADOR	H	F	A	G	MEDIDA	€
CODE	ACTUATOR	H	F	A	G	SIZE	€
52051142-050	5200052	248	92	145	71	2"	160,38
52051142-065	5200052	260	92	145	71	2 1/2"	167,23
52051142-080	5200063	284	108	169	82	3"	225,73
52051142-100	5200063	301	108	169	82	4"	248,01
52051142-125	5200083	336	128	209	101	5"	356,62
52051142-150	5200092	359	140	242	109	6"	414,20
52051142-200	5200125	442	175	332	138	8"	718,64
52051142-250	5200140	489	192	385	153	10"	1.018,02

- Actuadores neumáticos ATEX
Pneumatic actuators ATEX
- Los actuadores neumáticos están calculados en base a una presión de aire de entrada de 6 Bares
Pneumatic actuators are calculated based on a inlet air pressure of 6 Bar

ACTUADOR ELÉCTRICO BAJO VOLTAJE ELECTRIC ACTUATOR LOW VOLTAGE



CÓDIGO	ACTUADOR	H	F	A	G	MEDIDA	€
CODE	ACTUATOR	H	F	A	G	SIZE	€
53251142-050	5324020	325	169	181	110	2"	365,61
53251142-065	5324035	337	169	181	110	2 1/2"	470,94
53251142-080	5324055	345	169	181	110	3"	582,28
53251142-100	5324055	389	196	181	110	4"	604,56
53251142-125	5324085	404	196	181	128	5"	781,36
53251142-150	5324140	458	254	235	214	6"	963,74
53251142-200	5324300	521	254	235	214	8"	1.220,22
53251142-250	5324300	551	254	235	214	10"	1.384,78

- 12V VAC/VDC

ACTUADOR ELÉCTRICO ALTO VOLTAJE ELECTRIC ACTUATOR HIGH VOLTAGE



CÓDIGO	ACTUADOR	H	F	A	G	MEDIDA	€
CODE	ACTUATOR	H	F	A	G	SIZE	€
53051142-050	5300020	325	169	181	110	2"	365,61
53051142-065	5324035	337	169	181	110	2 1/2"	470,94
53051142-080	5324055	345	169	181	110	3"	582,28
53051142-100	5300055	389	196	181	110	4"	604,56
53051142-125	5300085	404	196	181	128	5"	781,36
53051142-150	5300140	458	254	235	214	6"	963,74
53051142-200	5300300	521	254	235	214	8"	1.220,22
53051142-250	5300300	551	254	235	214	10"	1.384,78

- 24V-240V VAC/VDC

H ALTURA DESDE EJE DE VÁLVULA A LA PARTE SUPERIOR DEL ACTUADOR / HIGH FROM VALVE AXIS TO ACTUATOR TOP
F ALTURA DEL ACTUADOR / ACTUATOR HIGH
A LONGITUD DEL ACTUADOR / ACTUATOR LENGTH
G GROSOR DEL ACTUADOR / ACTUATOR THICKNESS

5144

VÁLVULA DE MARIPOSA TIPO LUG DISCO INOX. ASIENTO BLANDO NBR CON ACTUADOR / BUTTERFLY VALVE LUG TYPE STAINLESS STEEL DISC NBR SOFT SEAT WITH ACTUATOR

SIMPLE EFECTO SIMPLE RETURN ACTUATOR



CÓDIGO	ACTUADOR	H	F	A	G	MEDIDA	€
CODE	ACTUATOR	H	F	A	G	SIZE	€
5105144-050	5100075	276	120	201	94	2"	274,14
5105144-065	5100083	296	128	209	101	2 1/2"	308,53
5105144-080	5100092	316	140	242	108,5	3"	397,96
5105144-100	5100105	346	153	275	122	4"	507,84
5105144-125	5100125	383	175	332	137,5	5"	654,90
5105144-150	5100140	415,5	191,5	385	153	6"	932,97
5105144-200	5100140	458,5	191,5	385	153	8"	1.053,20

- Actuadores neumáticos ATEX
Pneumatic actuators ATEX
- Los actuadores neumáticos están calculados en base a una presión de aire de entrada de 6 Bares
Pneumatic actuators are calculated based on a inlet air pressure of 6 Bar

DOBLE EFECTO DOUBLE ACTING ACTUATOR



CÓDIGO	ACTUADOR	H	F	A	G	MEDIDA	€
CODE	ACTUATOR	H	F	A	G	SIZE	€
5205144-050	5200052	248	92	145	71	2"	168,11
5205144-065	5200063	276	108	169	82	2 1/2"	215,05
5205144-080	5200075	296	120	201	94	3"	284,11
5205144-100	5200075	313	120	201	94	4"	312,95
5205144-125	5200092	348	140	242	108,5	5"	408,74
5205144-150	5200092	359	140	242	108,5	6"	436,78
5205144-200	5200105	420	153	275	122	8"	677,14

- Actuadores neumáticos ATEX
Pneumatic actuators ATEX
- Los actuadores neumáticos están calculados en base a una presión de aire de entrada de 6 Bares
Pneumatic actuators are calculated based on a inlet air pressure of 6 Bar

ACTUADOR ELÉCTRICO BAJO VOLTAJE ELECTRIC ACTUATOR LOW VOLTAGE



CÓDIGO	ACTUADOR	H	F	A	G	MEDIDA	€
CODE	ACTUATOR	H	F	A	G	SIZE	€
5325144-050	5324020	325	169	181	110	2"	373,95
5325144-065	5324035	337	169	181	110	2 1/2"	480,65
5325144-080	5324055	372	196	181	110	3"	597,96
5325144-100	5324085	389	196	181	128	4"	746,79
5325144-125	5324140	447	254	235	214	5"	946,30
5325144-150	5324140	458	254	235	214	6"	978,63
5325144-200	5324300	521	254	235	214	8"	1.222,74

- 12V VAC/VDC

ACTUADOR ELÉCTRICO ALTO VOLTAJE ELECTRIC ACTUATOR HIGH VOLTAGE



CÓDIGO	ACTUADOR	H	F	A	G	MEDIDA	€
CODE	ACTUATOR	H	F	A	G	SIZE	€
5305144-050	5300020	325	169	181	110	2"	373,95
5305144-065	5300035	337	169	181	110	2 1/2"	480,65
5305144-080	5300055	372	196	181	110	3"	597,96
5305144-100	5300085	389	196	181	128	4"	746,79
5305144-125	5300140	447	254	235	214	5"	946,30
5305144-150	5300140	458	254	235	214	6"	978,63
5305144-200	5300300	521	254	235	214	8"	1.222,74

- 24V-240V VAC/VDC

H ALTURA DESDE EJE DE VÁLVULA A LA PARTE SUPERIOR DEL ACTUADOR / HIGH FROM VALVE AXIS TO ACTUATOR TOP
F ALTURA DEL ACTUADOR / ACTUATOR HIGH
A LONGITUD DEL ACTUADOR / ACTUATOR LENGTH
G GROSOR DEL ACTUADOR / ACTUATOR THICKNESS

51143

VÁLVULA DE MARIPOSA TIPO WAFER DISCO Y ASIENTO PTFE CON ACTUADOR
BUTTERFLY VALVE WAFER TYPE PTFE DISC AND SEAT WITH ACTUATOR

SIMPLE EFECTO SIMPLE RETURN ACTUATOR



CÓDIGO	ACTUADOR	H	F	A	G	MEDIDA	€
CODE	ACTUATOR	H	F	A	G	SIZE	€
51051143-050	5100083	279	128	209	101	2"	619,16
51051143-065	5100083	283	128	209	101	2 1/2"	705,70
51051143-080	5100092	295	140	242	108,5	3"	882,88
51051143-100	5100105	326	153	275	122	4"	1.167,13
51051143-125	5100125	360	175	332	137,5	5"	1.519,02
51051143-150	5100140	401,5	191,5	385	153	6"	1.975,46
51051143-200	5100160	469	217	450	174	8"	3.254,58
51051143-250	-	-	-	-	-	10"	Consultar
51051143-300	-	-	-	-	-	12"	Consultar

- Actuadores neumáticos ATEX
Pneumatic actuators ATEX
- Los actuadores neumáticos están calculados en base a una presión de aire de entrada de 6 Bares
Pneumatic actuators are calculated based on a inlet air pressure of 6 Bar

DOBLE EFECTO DOUBLE ACTING ACTUATOR



CÓDIGO	ACTUADOR	H	F	A	G	MEDIDA	€
CODE	ACTUATOR	H	F	A	G	SIZE	€
52051143-050	5200063	259	108	169	82	2"	497,64
52051143-065	5200063	263	108	169	82	2 1/2"	584,18
52051143-080	5200075	275	120	201	94	3"	749,96
52051143-100	5200083	301	128	209	101	4"	972,18
52051143-125	5200092	325	140	242	108,5	5"	1.211,10
52051143-150	5200105	343	153	275	122	6"	1.510,22
52051143-200	5200125	427	175	332	137,5	8"	2.536,13
52051143-250	-	-	-	-	-	10"	Consultar
52051143-300	-	-	-	-	-	12"	Consultar

- Actuadores neumáticos ATEX
Pneumatic actuators ATEX
- Los actuadores neumáticos están calculados en base a una presión de aire de entrada de 6 Bares
Pneumatic actuators are calculated based on a inlet air pressure of 6 Bar

ACTUADOR ELÉCTRICO BAJO VOLTAJE ELECTRIC ACTUATOR LOW VOLTAGE



CÓDIGO	ACTUADOR	H	F	A	G	MEDIDA	€
CODE	ACTUATOR	H	F	A	G	SIZE	€
53251143-050	5324035	325	169	181	110	2"	842,92
53251143-065	5324035	337	169	181	110	2 1/2"	929,46
53251143-080	5324055	372	196	181	110	3"	1.138,96
53251143-100	5324085	389	196	181	128	4"	1.473,85
53251143-125	5324140	447	254	235	214	5"	1.874,30
53251143-150	5324140	458	254	235	214	6"	2.056,02
53251143-200	5324300	521	254	235	214	8"	3.092,26

- 12V VAC/VDC

ACTUADOR ELÉCTRICO ALTO VOLTAJE ELECTRIC ACTUATOR HIGH VOLTAGE



CÓDIGO	ACTUADOR	H	F	A	G	MEDIDA	€
CODE	ACTUATOR	H	F	A	G	SIZE	€
53051143-050	5300035	325	169	181	110	2"	842,92
53051143-065	5300035	337	169	181	110	2 1/2"	929,46
53051143-080	5300055	372	196	181	110	3"	1.138,96
53051143-100	5300085	389	196	181	128	4"	1.473,85
53051143-125	5300140	447	254	235	214	5"	1.874,30
53051143-150	5300140	458	254	235	214	6"	2.056,02
53051143-200	5300300	521	254	235	214	8"	3.092,26

- 24V-240V VAC/VDC

H ALTURA DESDE EJE DE VÁLVULA A LA PARTE SUPERIOR DEL ACTUADOR / HIGH FROM VALVE AXIS TO ACTUATOR TOP
F ALTURA DEL ACTUADOR / ACTUATOR HIGH
A LONGITUD DEL ACTUADOR / ACTUATOR LENGTH
G GROSOR DEL ACTUADOR / ACTUATOR THICKNESS

0917

VÁLVULA DE ESFERA DOS PIEZAS ROSCAR CON PLETINA ISO Y ACTUADOR / TWO PIECES BALL VALVE FULL BORE THREADED END ISO MOUNTING PAD WITH ACTUATOR

SIMPLE EFECTO
SIMPLE RETURN ACTUATOR



CÓDIGO	ACTUADOR	H	F	A	G	MEDIDA	€
CODE	ACTUATOR	H	F	A	G	SIZE	€
5100917-008	5100052	128,5	92	145	71	1/4"	146,95
5100917-010	5100052	129	92	145	71	3/8"	146,95
5100917-015	5100052	131	92	145	71	1/2"	147,54
5100917-020	5100052	133,5	92	145	71	3/4"	153,25
5100917-025	5100063	155	108	169	82	1"	197,25
5100917-032	5100075	172	120	201	94	1 1/4"	253,05
5100917-040	5100083	190	128	209	101	1 1/2"	293,19
5100917-050	5100092	211	140	242	108,5	2"	386,62

- Actuadores neumáticos ATEX
Pneumatic actuators ATEX
- Los actuadores neumáticos están calculados en base a una presión de aire de entrada de 6 Bares
Pneumatic actuators are calculated based on a inlet air pressure of 6 Bar

DOBLE EFECTO
DOUBLE ACTING ACTUATOR



CÓDIGO	ACTUADOR	H	F	A	G	MEDIDA	€
CODE	ACTUATOR	H	F	A	G	SIZE	€
5200917-008	5200052	128,5	92	145	71	1/4"	131,57
5200917-010	5200052	129	92	145	71	3/8"	131,57
5200917-015	5200052	131	92	145	71	1/2"	132,16
5200917-020	5200052	133,5	92	145	71	3/4"	137,86
5200917-025	5200052	139	92	145	71	1"	146,97
5200917-032	5200063	160	108	169	82	1 1/4"	193,69
5200917-040	5200075	182	120	201	94	1 1/2"	242,42
5200917-050	5200075	191	120	201	94	2"	272,77

- Actuadores neumáticos ATEX
Pneumatic actuators ATEX
- Los actuadores neumáticos están calculados en base a una presión de aire de entrada de 6 Bares
Pneumatic actuators are calculated based on a inlet air pressure of 6 Bar

ACTUADOR ELÉCTRICO BAJO VOLTAJE ELECTRIC ACTUATOR LOW VOLTAGE



CÓDIGO	ACTUADOR	H	F	A	G	MEDIDA	€
CODE	ACTUATOR	H	F	A	G	SIZE	€
5320917-008**	5324010	160,5	124	169	104	1/4"	269,54
5320917-010**	5324010	161	124	169	104	3/8"	269,54
5320917-015**	5324010	163	124	169	104	1/2"	270,13
5320917-020*	5324020	210,5	169	181	110	3/4"	331,22
5320917-025*	5324020	216	169	181	110	1"	344,97
5320917-032*	5324035	221	169	181	110	1 1/4"	457,42
5320917-040*	5324035	231	169	181	110	1 1/2"	468,95
5320917-050*	5324055	267	196	181	110	2"	586,62

- *12V / **24V VAC/VDC

ACTUADOR ELÉCTRICO ALTO VOLTAJE ELECTRIC ACTUATOR HIGH VOLTAGE



CÓDIGO	ACTUADOR	H	F	A	G	MEDIDA	€
CODE	ACTUATOR	H	F	A	G	SIZE	€
5300917-008**	5300010	160,5	124	169	104	1/4"	269,54
5300917-010**	5300010	161	124	169	104	3/8"	269,54
5300917-015**	5300010	163	124	169	104	1/2"	270,13
5300917-020*	5300020	211	169	181	110	3/4"	331,22
5300917-025*	5300020	216	169	181	110	1"	344,97
5300917-032*	5300035	221	169	181	110	1 1/4"	457,42
5300917-040*	5300035	231	169	181	110	1 1/2"	468,95
5300917-050*	5300055	267	196	181	110	2"	586,62

- *24V-240V / **85V-240V VAC/VDC

H ALTURA DESDE EJE DE VÁLVULA A LA PARTE SUPERIOR DEL ACTUADOR / HIGH FROM VALVE AXIS TO ACTUATOR TOP
F ALTURA DEL ACTUADOR / ACTUATOR HIGH
A LONGITUD DEL ACTUADOR / ACTUATOR LENGTH
G GROSOR DEL ACTUADOR / ACTUATOR THICKNESS

0918

VÁLVULA DE ESFERA TRES VÍAS PASO EN L CON PLETINA ISO Y ACTUADOR
THREE WAY BALL VALVE L-TYPE FULL BORE ISO MOUNTING PAD WITH ACTUATOR

SIMPLE EFECTO SIMPLE RETURN ACTUATOR



CÓDIGO	ACTUADOR	H	F	A	G	MEDIDA	€
CODE	ACTUATOR	H	F	A	G	SIZE	€
5100918-008	5100052	134	92	145	71	1/4"	169,97
5100918-010	5100052	134	92	145	71	3/8"	169,97
5100918-015	5100052	134	92	145	71	1/2"	169,97
5100918-020	5100063	157	108	169	82	3/4"	205,21
5100918-025	5100063	168	108	169	82	1"	226,76
5100918-032	5100083	191	128	209	101	1 1/4"	315,82
5100918-040	5100083	202	128	209	101	1 1/2"	366,25
5100918-050	5100092	223	140	242	108,5	2"	498,17

- Actuadores neumáticos ATEX
Pneumatic actuators ATEX
- Los actuadores neumáticos están calculados en base a una presión de aire de entrada de 6 Bares
Pneumatic actuators are calculated based on a inlet air pressure of 6 Bar

DOBLE EFECTO DOUBLE ACTING ACTUATOR

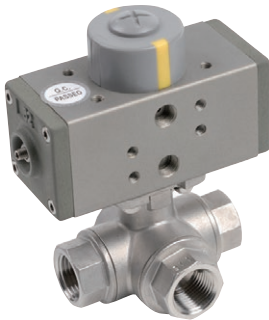

CÓDIGO	ACTUADOR	H	F	A	G	MEDIDA	€
CODE	ACTUATOR	H	F	A	G	SIZE	€
5200918-008	5200052	134	92	145	71	1/4"	154,59
5200918-010	5200052	134	92	145	71	3/8"	154,59
5200918-015	5200052	134	92	145	71	1/2"	154,59
5200918-020	5200052	141	92	145	71	3/4"	162,14
5200918-025	5200052	152	92	145	71	1"	176,45
5200918-032	5200063	171	108	169	82	1 1/4"	232,35
5200918-040	5200063	182	108	169	82	1 1/2"	266,71
5200918-050	5200075	203	120	201	94	2"	394,15

- Actuadores neumáticos ATEX
Pneumatic actuators ATEX
- Los actuadores neumáticos están calculados en base a una presión de aire de entrada de 6 Bares
Pneumatic actuators are calculated based on a inlet air pressure of 6 Bar

ACTUADOR ELÉCTRICO BAJO VOLTAJE ELECTRIC ACTUATOR LOW VOLTAGE



CÓDIGO	ACTUADOR	H	F	A	G	MEDIDA	€
CODE	ACTUATOR	H	F	A	G	SIZE	€
5320918-008	5324020	211	169	181	110	1/4"	346,34
5320918-010	5324020	211	169	181	110	3/8"	346,34
5320918-015	5324020	211	169	181	110	1/2"	346,34
5320918-020	5324020	218	169	181	110	3/4"	353,89
5320918-025	5324020	229	169	181	110	1"	374,32
5320918-032	5324035	232	169	181	110	1 1/4"	495,95
5320918-040	5324055	243	169	181	110	1 1/2"	633,18
5320918-050	5324085	279	196	181	128	2"	837,16

- 12V VAC/VDC

ACTUADOR ELÉCTRICO ALTO VOLTAJE ELECTRIC ACTUATOR HIGH VOLTAGE



CÓDIGO	ACTUADOR	H	F	A	G	MEDIDA	€
CODE	ACTUATOR	H	F	A	G	SIZE	€
5300918-008	5300020	211	169	181	110	1/4"	346,34
5300918-010	5300020	211	169	181	110	3/8"	346,34
5300918-015	5300020	211	169	181	110	1/2"	346,34
5300918-020	5300020	218	169	181	110	3/4"	353,89
5300918-025	5300020	229	169	181	110	1"	374,32
5300918-032	5300035	232	169	181	110	1 1/4"	495,95
5300918-040	5300055	243	169	181	110	1 1/2"	633,18
5300918-050	5300085	279	196	181	128	2"	837,16

- 24V-240V VAC/VDC

H ALTURA DESDE EJE DE VÁLVULA A LA PARTE SUPERIOR DEL ACTUADOR / HIGH FROM VALVE AXIS TO ACTUATOR TOP
F ALTURA DEL ACTUADOR / ACTUATOR HIGH
A LONGITUD DEL ACTUADOR / ACTUATOR LENGTH
G GROSOR DEL ACTUADOR / ACTUATOR THICKNESS

0919

VÁLVULA DE ESFERA TRES VÍAS PASO EN T PLETINA ISO CON ACTUADOR
THREE WAY BALL VALVE T-TYPE FULL BORE ISO MOUNTING PAD WITH ACTUATOR

SIMPLE EFECTO
SIMPLE RETURN ACTUATOR



CÓDIGO	ACTUADOR	H	F	A	G	MEDIDA	€
CODE	ACTUATOR	H	F	A	G	SIZE	€
5100919-008	5100052	134	92	145	71	1/4"	169,97
5100919-010	5100052	134	92	145	71	3/8"	169,97
5100919-015	5100052	134	92	145	71	1/2"	169,97
5100919-020	5100063	157	108	169	82	3/4"	205,21
5100919-025	5100063	168	108	169	82	1"	226,76
5100919-032	5100083	191	128	209	101	1 1/4"	315,82
5100919-040	5100083	202	128	209	101	1 1/2"	366,25
5100919-050	5100092	223	140	242	108,5	2"	498,17

- Actuadores neumáticos ATEX
Pneumatic actuators ATEX
- Los actuadores neumáticos están calculados en base a una presión de aire de entrada de 6 Bares
Pneumatic actuators are calculated based on a inlet air pressure of 6 Bar

DOBLE EFECTO
DOUBLE ACTING ACTUATOR



CÓDIGO	ACTUADOR	H	F	A	G	MEDIDA	€
CODE	ACTUATOR	H	F	A	G	SIZE	€
5200919-008	5200052	134	92	145	71	1/4"	154,59
5200919-010	5200052	134	92	145	71	3/8"	154,59
5200919-015	5200052	134	92	145	71	1/2"	154,59
5200919-020	5200052	141	92	145	71	3/4"	162,14
5200919-025	5200052	152	92	145	71	1"	176,45
5200919-032	5200063	171	108	169	82	1 1/4"	232,35
5200919-040	5200063	182	108	169	82	1 1/2"	266,71
5200919-050	5200075	203	120	201	94	2"	394,15

- Actuadores neumáticos ATEX
Pneumatic actuators ATEX
- Los actuadores neumáticos están calculados en base a una presión de aire de entrada de 6 Bares
Pneumatic actuators are calculated based on a inlet air pressure of 6 Bar

ACTUADOR ELÉCTRICO BAJO VOLTAJE ELECTRIC ACTUATOR LOW VOLTAGE



CÓDIGO	ACTUADOR	H	F	A	G	MEDIDA	€
CODE	ACTUATOR	H	F	A	G	SIZE	€
5320919-008	5324020	211	169	181	110	1/4"	346,34
5320919-010	5324020	211	169	181	110	3/8"	346,34
5320919-015	5324020	211	169	181	110	1/2"	346,34
5320919-020	5324020	218	169	181	110	3/4"	353,89
5320919-025	5324020	229	169	181	110	1"	374,32
5320919-032	5324035	232	169	181	110	1 1/4"	495,95
5320919-040	5324055	243	169	181	110	1 1/2"	633,18
5320919-050	5324085	279	196	181	128	2"	837,16

- 12V VAC/VDC

ACTUADOR ELÉCTRICO ALTO VOLTAJE ELECTRIC ACTUATOR HIGH VOLTAGE



CÓDIGO	ACTUADOR	H	F	A	G	MEDIDA	€
CODE	ACTUATOR	H	F	A	G	SIZE	€
5300919-008	5300020	211	169	181	110	1/4"	346,34
5300919-010	5300020	211	169	181	110	3/8"	346,34
5300919-015	5300020	211	169	181	110	1/2"	346,34
5300919-020	5300020	218	169	181	110	3/4"	353,89
5300919-025	5300020	229	169	181	110	1"	374,32
5300919-032	5300035	232	169	181	110	1 1/4"	495,95
5300919-040	5300055	243	169	181	110	1 1/2"	633,18
5300919-050	5300085	279	196	181	128	2"	837,16

- 24V-240V VAC/VDC

H ALTURA DESDE EJE DE VÁLVULA A LA PARTE SUPERIOR DEL ACTUADOR / HIGH FROM VALVE AXIS TO ACTUATOR TOP
F ALTURA DEL ACTUADOR / ACTUATOR HIGH
A LONGITUD DEL ACTUADOR / ACTUATOR LENGTH
G GROSOR DEL ACTUADOR / ACTUATOR THICKNESS

5117

VÁLVULA DE ESFERA DOS PIEZAS ACERO AL CARBONO BOLA A-316 BRIDA CON ACTUADOR / TWO PIECES BALL VALVES WCB FLANGED END WITH ACTUATOR

SIMPLE EFECTO SIMPLE RETURN ACTUATOR



CÓDIGO	ACTUADOR	H	F	A	G	MEDIDA	€
CODE	ACTUATOR	H	F	A	G	SIZE	€
5105117-015	5100052	141	92	145	71	1/2"	180,06
5105117-020	5100052	146	92	145	71	3/4"	193,10
5105117-025	5100063	167	108	169	82	1"	242,81
5105117-032	5100075	191	120	201	94	1 1/4"	311,46
5105117-040	5100083	206	128	209	101	1 1/2"	362,48
5105117-050	5100092	225	140	242	108,5	2"	464,30
5105117-065	5100105	253	153	275	122	2 1/2"	640,09
5105117-080	5100125	285	175	332	137,5	3"	814,51
5105117-100	5100160	347	217	450	174	4"	1.425,87
5105117-125	5100190	445	260	507	206	5"	2.432,00
5105117-150	5100210	485	285	562	226	6"	2.944,32
5105117-200	-	-	-	-	-	8"	-

- Actuadores neumáticos ATEX
Pneumatic actuators ATEX
- Los actuadores neumáticos están calculados en base a una presión de aire de entrada de 6 Bares
Pneumatic actuators are calculated based on a inlet air pressure of 6 Bar

DOBLE EFECTO DOUBLE ACTING ACTUATOR



CÓDIGO	ACTUADOR	H	F	A	G	MEDIDA	€
CODE	ACTUATOR	H	F	A	G	SIZE	€
5205117-015	5200052	141	92	145	71	1/2"	164,67
5205117-020	5200052	146	92	145	71	3/4"	177,72
5205117-025	5200052	151	92	145	71	1"	192,50
5205117-032	5200052	163	92	145	71	1 1/4"	221,37
5205117-040	5200063	186	108	169	82	1 1/2"	284,94
5205117-050	5200075	205	120	201	94	2"	350,45
5205117-065	5200083	228	128	209	101	2 1/2"	443,02
5205117-080	5200092	250	140	242	108,5	3"	560,51
5205117-100	5200125	305	175	332	137,5	4"	814,54
5205117-125	5200140	356,5	191,5	385	153	5"	1.360,11
5205117-150	5200160	397	217	450	174	6"	1.707,17
5205117-200	-	-	-	-	-	8"	-

- Actuadores neumáticos ATEX
Pneumatic actuators ATEX
- Los actuadores neumáticos están calculados en base a una presión de aire de entrada de 6 Bares
Pneumatic actuators are calculated based on a inlet air pressure of 6 Bar

ACTUADOR ELÉCTRICO BAJO VOLTAJE ELECTRIC ACTUATOR LOW VOLTAGE



CÓDIGO	ACTUADOR	H	F	A	G	MEDIDA	€
CODE	ACTUATOR	H	F	A	G	SIZE	€
5325117-015**	5324010	173	124	169	104	1/2"	302,64
5325117-020**	5324010	178	124	169	104	3/4"	315,69
5325117-025*	5324020	228	169	181	110	1"	390,50
5325117-032*	5324035	240	169	181	110	1 1/4"	517,83
5325117-040*	5324035	247	169	181	110	1 1/2"	538,35
5325117-050*	5324055	281	196	181	110	2"	665,04
5325117-065*	5324085	296	196	181	128	2 1/2"	868,37
5325117-080*	5324140	364	254	235	214	3"	1.112,97
5325117-100*	5324300	384	254	235	214	4"	1.314,54

- *12V / **24V VAC/VDC

ACTUADOR ELÉCTRICO ALTO VOLTAJE ELECTRIC ACTUATOR HIGH VOLTAGE



CÓDIGO	ACTUADOR	H	F	A	G	MEDIDA	€
CODE	ACTUATOR	H	F	A	G	SIZE	€
5305117-015**	5300010	173	124	169	104	1/2"	302,64
5305117-020**	5300010	178	124	169	104	3/4"	315,69
5305117-025*	5300020	228	169	181	110	1"	390,50
5305117-032*	5300035	240	169	181	110	1 1/4"	517,83
5305117-040*	5300035	247	169	181	110	1 1/2"	538,35
5305117-050*	5300055	281	196	181	110	2"	665,04
5305117-065*	5300085	296	196	181	128	2 1/2"	868,37
5305117-080*	5300140	364	254	235	214	3"	1.112,97
5305117-100*	5300300	384	254	235	214	4"	1.314,54

- *24V-240V / **85V-240V VAC/VDC

H ALTURA DESDE EJE DE VÁLVULA A LA PARTE SUPERIOR DEL ACTUADOR / HIGH FROM VALVE AXIS TO ACTUATOR TOP
F ALTURA DEL ACTUADOR / ACTUATOR HIGH
A LONGITUD DEL ACTUADOR / ACTUATOR LENGTH
G GROSOR DEL ACTUADOR / ACTUATOR THICKNESS

5128

VÁLVULA DE ESFERA DOS PIEZAS INOXIDABLE BRIDA ACTUADA
TWO PIECES BALL VALVE STAINLESS STEEL FLANGED END WITH ACTUATOR

SIMPLE EFECTO SIMPLE RETURN ACTUATOR



CÓDIGO	ACTUADOR	H	F	A	G	MEDIDA	€
CODE	ACTUATOR	H	F	A	G	SIZE	€
5105128-015	5100052	141	92	145	71	1/2"	228,49
5105128-020	5100052	146	92	145	71	3/4"	246,98
5105128-025	5100063	167	108	169	82	1"	300,18
5105128-032	5100075	191	120	201	94	1 1/4"	396,41
5105128-040	5100083	206	128	209	101	1 1/2"	461,58
5105128-050	5100092	225	140	242	108,5	2"	625,55
5105128-065	5100105	253	153	275	122	2 1/2"	868,00
5105128-080	5100125	285	175	332	137,5	3"	1.123,36
5105128-100	5100140	321,5	191,5	385	153	4"	1.597,46
5105128-125	5100160	382	217	450	174	5"	2.966,85
5105128-150	5100210	485	285	562	226	6"	4.472,15

- Actuadores neumáticos ATEX
Pneumatic actuators ATEX
- Los actuadores neumáticos están calculados en base a una presión de aire de entrada de 6 Bares
Pneumatic actuators are calculated based on a inlet air pressure of 6 Bar

DOBLE EFECTO DOUBLE ACTING ACTUATOR



CÓDIGO	ACTUADOR	H	F	A	G	MEDIDA	€
CODE	ACTUATOR	H	F	A	G	SIZE	€
5205128-015	5200052	141	92	145	71	1/2"	210,31
5205128-020	5200052	146	92	145	71	3/4"	228,79
5205128-025	5200052	151	92	145	71	1"	257,81
5205128-032	5200052	163	92	145	71	1 1/4"	325,87
5205128-040	5200063	186	108	169	82	1 1/2"	358,09
5205128-050	5200075	205	120	201	94	2"	510,47
5205128-065	5200083	228	128	209	101	2 1/2"	723,64
5205128-080	5200092	250	140	242	108,5	3"	931,15
5205128-100	5200125	305	175	332	137,5	4"	1.378,64
5205128-125	5200140	356,5	191,5	385	153	5"	2.548,00
5205128-150	5200160	397	217	450	174	6"	3.550,10

- Actuadores neumáticos ATEX
Pneumatic actuators ATEX
- Los actuadores neumáticos están calculados en base a una presión de aire de entrada de 6 Bares
Pneumatic actuators are calculated based on a inlet air pressure of 6 Bar

ACTUADOR ELÉCTRICO BAJO VOLTAJE ELECTRIC ACTUATOR LOW VOLTAGE



CÓDIGO	ACTUADOR	H	F	A	G	MEDIDA	€
CODE	ACTUATOR	H	F	A	G	SIZE	€
5325128-015**	5324010	173	124	169	104	1/2"	373,37
5325128-020**	5324010	178	124	169	104	3/4"	391,85
5325128-025*	5324020	228	169	181	110	1"	483,27
5325128-032*	5324035	240	169	181	110	1 1/4"	637,90
5325128-040*	5324035	247	169	181	110	1 1/2"	669,29
5325128-050*	5324055	281	196	181	110	2"	833,71
5325128-065*	5324085	296	196	181	128	2 1/2"	1.149,65
5325128-080*	5324140	364	254	235	214	3"	1.502,91
5325128-100*	5324140	384	254	235	214	4"	1.810,65

- * 12V / **24V VAC/VDC

ACTUADOR ELÉCTRICO ALTO VOLTAJE ELECTRIC ACTUATOR HIGH VOLTAGE



CÓDIGO	ACTUADOR	H	F	A	G	MEDIDA	€
CODE	ACTUATOR	H	F	A	G	SIZE	€
5305128-015**	5300010	173	124	169	104	1/2"	373,37
5305128-020**	5300010	178	124	169	104	3/4"	391,85
5305128-025*	5300020	228	169	181	110	1"	483,27
5305128-032*	5300035	240	169	181	110	1 1/4"	637,90
5305128-040*	5300035	247	169	181	110	1 1/2"	669,29
5305128-050*	5300055	281	196	181	110	2"	833,71
5305128-065*	5300085	296	196	181	128	2 1/2"	1.149,65
5305128-080*	5300140	364	254	235	214	3"	1.502,91
5305128-100*	5300140	384	254	235	214	4"	1.810,65

- * 24V-240V / **85V-240V VAC/VDC

H ALTURA DESDE EJE DE VÁLVULA A LA PARTE SUPERIOR DEL ACTUADOR / HIGH FROM VALVE AXIS TO ACTUATOR TOP
F ALTURA DEL ACTUADOR / ACTUATOR HIGH
A LONGITUD DEL ACTUADOR / ACTUATOR LONGITUDE
G GROSOR DEL ACTUADOR / ACTUATOR THICKNESS

91120

VÁLVULA DE ESFERA TRES PIEZAS SOCKED WELD PASO TOTAL CON PLETINA ISO Y ACTUADOR / THREE PIECES BALL VALVE SOCKED WELD FULL BORE ISO MOUNTING PAD WITH ACTUATOR

SIMPLE EFECTO SIMPLE RETURN ACTUATOR



CÓDIGO	ACTUADOR	H	F	A	G	MEDIDA	€
CODE	ACTUATOR	H	F	A	G	SIZE	€
51091120-015	5100052	131	92	145	71	1/2"	138,80
51091120-020	5100052	133,5	92	145	71	3/4"	143,86
51091120-025	5100063	155	108	169	82	1"	180,43
51091120-032	5100063	160	108	169	82	1 1/4"	206,91
51091120-040	5100075	182	120	201	94	1 1/2"	257,46
51091120-050	5100083	199	128	209	101	2"	314,76
51091120-065	5100092	229	140	242	108,5	2 1/2"	552,19

- Actuadores neumáticos ATEX
Pneumatic actuators ATEX
- Los actuadores neumáticos están calculados en base a una presión de aire de entrada de 6 Bares
Pneumatic actuators are calculated based on a inlet air pressure of 6 Bar

DOBLE EFECTO DOUBLE ACTING ACTUATOR



CÓDIGO	ACTUADOR	H	F	A	G	MEDIDA	€
CODE	ACTUATOR	H	F	A	G	SIZE	€
52091120-015	5200052	131	92	145	71	1/2"	124,52
52091120-020	5200052	133,5	92	145	71	3/4"	129,58
52091120-025	5200052	139	92	145	71	1"	133,72
52091120-032	5200052	144	92	145	71	1 1/4"	148,10
52091120-040	5200063	170	108	169	82	1 1/2"	189,90
52091120-050	5200063	179	108	169	82	2"	221,35
52091120-065	5200083	217	128	209	101	2 1/2"	456,64

- Actuadores neumáticos ATEX
Pneumatic actuators ATEX
- Los actuadores neumáticos están calculados en base a una presión de aire de entrada de 6 Bares
Pneumatic actuators are calculated based on a inlet air pressure of 6 Bar

ACTUADOR ELÉCTRICO BAJO VOLTAJE ELECTRIC ACTUATOR LOW VOLTAGE



CÓDIGO	ACTUADOR	H	F	A	G	MEDIDA	€
CODE	ACTUATOR	H	F	A	G	SIZE	€
53291120-015**	5324010	163	124	169	104	1/2"	251,49
53291120-020*	5324020	210,5	169	181	110	3/4"	314,76
53291120-025*	5324020	216	169	181	110	1"	325,34
53291120-032*	5324035	221	169	181	110	1 1/4"	444,46
53291120-040*	5324035	231	169	181	110	1 1/2"	464,79
53291120-050*	5324055	267	196	181	110	2"	584,76
53291120-065*	5324055	285	196	181	110	2 1/2"	760,45

- *12V / **24V VAC/VDC

ACTUADOR ELÉCTRICO ALTO VOLTAJE ELECTRIC ACTUATOR HIGH VOLTAGE



CÓDIGO	ACTUADOR	H	F	A	G	MEDIDA	€
CODE	ACTUATOR	H	F	A	G	SIZE	€
53091120-015**	5300010	163	124	169	104	1/2"	251,49
53091120-020*	5300020	210,5	169	181	110	3/4"	314,76
53091120-025*	5300020	216	169	181	110	1"	325,34
53091120-032*	5300035	221	169	181	110	1 1/4"	444,46
53091120-040*	5300035	231	169	181	110	1 1/2"	464,79
53091120-050*	5300055	267	196	181	110	2"	584,76
53091120-065*	5300055	285	196	181	110	2 1/2"	760,45

- *24V-240V / **85V-240V VAC/VDC

H ALTURA DESDE EJE DE VÁLVULA A LA PARTE SUPERIOR DEL ACTUADOR / HIGH FROM VALVE AXIS TO ACTUATOR TOP
F ALTURA DEL ACTUADOR / ACTUATOR HIGH
A LONGITUD DEL ACTUADOR / ACTUATOR LENGTH
G GROSOR DEL ACTUADOR / ACTUATOR THICKNESS

91020

VÁLVULA DE ESFERA TRES PIEZAS BUTT WELD PASO TOTAL CON PLETINA ISO Y ACTUADOR / THREE PIECES BALL VALVE BUTT WELD FULL BORE ISO MOUNTING PAD WITH ACTUATOR

SIMPLE EFECTO SIMPLE RETURN ACTUATOR



CÓDIGO	ACTUADOR	H	F	A	G	MEDIDA	€
CODE	ACTUATOR	H	F	A	G	SIZE	€
51091020-015	5100052	131	92	145	71	1/2"	138,80
51091020-020	5100052	133,5	92	145	71	3/4"	143,86
51091020-025	5100063	155	108	169	82	1"	180,43
51091020-032	5100063	160	108	169	82	1 1/4"	206,91
51091020-040	5100075	182	120	201	94	1 1/2"	257,46
51091020-050	5100083	199	128	209	101	2"	314,76
51091020-065	5100092	229	140	242	108,5	2 1/2"	552,19

- Actuadores neumáticos ATEX
Pneumatic actuators ATEX
- Los actuadores neumáticos están calculados en base a una presión de aire de entrada de 6 Bares
Pneumatic actuators are calculated based on a inlet air pressure of 6 Bar

DOBLE EFECTO DOUBLE ACTING ACTUATOR



CÓDIGO	ACTUADOR	H	F	A	G	MEDIDA	€
CODE	ACTUATOR	H	F	A	G	SIZE	€
52091020-015	5200052	131	92	145	71	1/2"	124,52
52091020-020	5200052	133,5	92	145	71	3/4"	129,58
52091020-025	5200052	139	92	145	71	1"	133,72
52091020-032	5200052	144	92	145	71	1 1/4"	148,10
52091020-040	5200063	170	108	169	82	1 1/2"	189,90
52091020-050	5200063	179	108	169	82	2"	221,35
52091020-065	5200083	217	128	209	101	2 1/2"	456,64

- Actuadores neumáticos ATEX
Pneumatic actuators ATEX
- Los actuadores neumáticos están calculados en base a una presión de aire de entrada de 6 Bares
Pneumatic actuators are calculated based on a inlet air pressure of 6 Bar

ACTUADOR ELÉCTRICO BAJO VOLTAJE ELECTRIC ACTUATOR LOW VOLTAGE



CÓDIGO	ACTUADOR	H	F	A	G	MEDIDA	€
CODE	ACTUATOR	H	F	A	G	SIZE	€
53291020-015**	5324010	163	124	169	104	1/2"	251,49
53291020-020*	5324020	210,5	169	181	110	3/4"	314,76
53291020-025*	5324020	216	169	181	110	1"	325,34
53291020-032*	5324035	221	169	181	110	1 1/4"	444,46
53291020-040*	5324035	231	169	181	110	1 1/2"	464,79
53291020-050*	5324055	267	196	181	110	2"	584,76
53291020-065*	5324055	285	196	181	110	2 1/2"	760,45

- *12V / **24V VAC/VDC

ACTUADOR ELÉCTRICO ALTO VOLTAJE ELECTRIC ACTUATOR HIGH VOLTAGE



CÓDIGO	ACTUADOR	H	F	A	G	MEDIDA	€
CODE	ACTUATOR	H	F	A	G	SIZE	€
53091020-015**	5300010	163	124	169	104	1/2"	251,49
53091020-020*	5300020	210,5	169	181	110	3/4"	314,76
53091020-025*	5300020	216	169	181	110	1"	325,34
53091020-032*	5300035	221	169	181	110	1 1/4"	444,46
53091020-040*	5300035	231	169	181	110	1 1/2"	464,79
53091020-050*	5300055	267	196	181	110	2"	584,76
53091020-065*	5300055	285	196	181	110	2 1/2"	760,45

- *24V-240V / **85V-240V VAC/VDC

H ALTURA DESDE EJE DE VÁLVULA A LA PARTE SUPERIOR DEL ACTUADOR / HIGH FROM VALVE AXIS TO ACTUATOR TOP
F ALTURA DEL ACTUADOR / ACTUATOR HIGH
A LONGITUD DEL ACTUADOR / ACTUATOR LENGTH
G GROSOR DEL ACTUADOR / ACTUATOR THICKNESS

0912

VÁLVULA DE ESFERA TRES PIEZAS ROSCAR PASO TOTAL CON PLETINA ISO Y ACTUADOR / THREE PIECES BALL VALVE THREADED END FULL BORE, ISO MOUNTING PAD WITH ACTUATOR

SIMPLE EFECTO SIMPLE RETURN ACTUATOR



CÓDIGO	ACTUADOR	H	F	A	G	MEDIDA	€
CODE	ACTUATOR	H	F	A	G	SIZE	€
5100912-008	5100052	131	92	145	71	1/4"	138,97
5100912-010	5100052	131	92	145	71	3/8"	138,97
5100912-015	5100052	131	92	145	71	1/2"	138,97
5100912-020	5100052	133,5	92	145	71	3/4"	143,86
5100912-025	5100063	155	108	169	82	1"	180,43
5100912-032	5100063	160	108	169	82	1 1/4"	232,11
5100912-040	5100075	182	120	201	94	1 1/2"	275,25
5100912-050	5100083	199	128	209	101	2"	327,02
5100912-065	5100092	229	140	242	108,5	2 1/2"	561,97
5100912-080	5100105	251	153	275	122	3"	749,39

- Actuadores neumáticos ATEX
Pneumatic actuators ATEX
- Los actuadores neumáticos están calculados en base a una presión de aire de entrada de 6 Bares
Pneumatic actuators are calculated based on a inlet air pressure of 6 Bar

DOBLE EFECTO DOUBLE ACTING ACTUATOR



CÓDIGO	ACTUADOR	H	F	A	G	MEDIDA	€
CODE	ACTUATOR	H	F	A	G	SIZE	€
5200912-008	5200052	131	92	145	71	1/4"	124,68
5200912-010	5200052	131	92	145	71	3/8"	124,68
5200912-015	5200052	131	92	145	71	1/2"	124,68
5200912-020	5200052	133,5	92	145	71	3/4"	129,58
5200912-025	5200052	139	92	145	71	1"	133,72
5200912-032	5200052	144	92	145	71	1 1/4"	148,10
5200912-040	5200063	170	108	169	82	1 1/2"	189,90
5200912-050	5200063	179	108	169	82	2"	212,10
5200912-065	5200083	217	128	209	101	2 1/2"	459,28
5200912-080	5200083	226	128	209	101	3"	578,94

- Actuadores neumáticos ATEX
Pneumatic actuators ATEX
- Los actuadores neumáticos están calculados en base a una presión de aire de entrada de 6 Bares
Pneumatic actuators are calculated based on a inlet air pressure of 6 Bar

ACTUADOR ELÉCTRICO BAJO VOLTAJE ELECTRIC ACTUATOR LOW VOLTAGE



CÓDIGO	ACTUADOR	H	F	A	G	MEDIDA	€
CODE	ACTUATOR	H	F	A	G	SIZE	€
5320912-008**	5324010	163	124	169	104	1/4"	251,66
5320912-010**	5324010	163	124	169	104	3/8"	251,66
5320912-015**	5324010	163	124	169	104	1/2"	251,66
5320912-020*	5324020	210,5	169	181	110	3/4"	318,45
5320912-025*	5324020	216	169	181	110	1"	322,64
5320912-032*	5324035	221	169	181	110	1 1/4"	444,93
5320912-040*	5324035	231	169	181	110	1 1/2"	469,34
5320912-050*	5324055	267	196	181	110	2"	588,17
5320912-065*	5324055	285	196	181	110	2 1/2"	764,52
5320912-080*	5324085	294	196	181	128	3"	1.015,67

- *12V / **24V VAC/VDC

ACTUADOR ELÉCTRICO ALTO VOLTAJE ELECTRIC ACTUATOR HIGH VOLTAGE



CÓDIGO	ACTUADOR	H	F	A	G	MEDIDA	€
CODE	ACTUATOR	H	F	A	G	SIZE	€
5300912-008**	5300010	163	124	169	104	1/4"	251,66
5300912-010**	5300010	163	124	169	104	3/8"	251,66
5300912-015**	5300010	163	124	169	104	1/2"	251,66
5300912-020*	5300020	210,5	169	181	110	3/4"	318,45
5300912-025*	5300020	216	169	181	110	1"	322,64
5300912-032*	5300035	221	169	181	110	1 1/4"	444,93
5300912-040*	5300035	231	169	181	110	1 1/2"	469,34
5300912-050*	5300055	267	196	181	110	2"	588,17
5300912-065*	5300055	285	196	181	110	2 1/2"	764,52
5300912-080*	5300085	294	196	181	128	3"	1.015,67

- *24V-240V / **85V-240V VAC/VDC

H ALTURA DESDE EJE DE VÁLVULA A LA PARTE SUPERIOR DEL ACTUADOR / HIGH FROM VALVE AXIS TO ACTUATOR TOP
F ALTURA DEL ACTUADOR / ACTUATOR HIGH
A LONGITUD DEL ACTUADOR / ACTUATOR LENGTH
G GROSOR DEL ACTUADOR / ACTUATOR THICKNESS

91031

VÁLVULA DE ESFERA WAFER PASO TOTAL CON PLETINA ISO CON ACTUADOR
BALL VALVE WAFER-TYPE WITH ISO MOUNTING PAD AND ACTUATOR

SIMPLE EFECTO SIMPLE RETURN ACTUATOR



CÓDIGO	ACTUADOR	H	F	A	G	MEDIDA	€
CODE	ACTUATOR	H	F	A	G	SIZE	€
51091031-015	5100052	139	92	145	71	1/2"	219,96
51091031-020	5100052	146	92	145	71	3/4"	238,62
51091031025	5100075	180	120	201	94	1"	339,35
51091031-032	5100075	192	120	201	94	1 1/4"	384,00
51091031-040	5100083	206	128	209	101	1 1/2"	442,87
51091031-050	5100092	225	140	242	108,5	2"	577,54
51091031-065	5100105	258	153	275	122	2 1/2"	770,13
51091031-080	5100125	290	175	332	137,5	3"	1.135,35
51091031-100	5100140	313,5	191,5	385	153	4"	1.512,84

- Actuadores neumáticos ATEX
Pneumatic actuators ATEX
- Los actuadores neumáticos están calculados en base a una presión de aire de entrada de 6 Bares
Pneumatic actuators are calculated based on a inlet air pressure of 6 Bar

DOBLE EFECTO DOUBLE ACTING ACTUATOR



CÓDIGO	ACTUADOR	H	F	A	G	MEDIDA	€
CODE	ACTUATOR	H	F	A	G	SIZE	€
52091031-015	5200052	139	92	145	71	1/2"	201,78
52091031-020	5200052	146	92	145	71	3/4"	220,44
52091031-025	5200052	152	92	145	71	1"	230,47
52091031-032	5200052	164	92	145	71	1 1/4"	275,13
52091031-040	5200063	186	108	169	82	1 1/2"	339,53
52091031-050	5200063	193	108	169	82	2"	399,65
52091031-065	5200075	225	120	201	94	2 1/2"	612,45
52091031-080	5200083	243	128	209	101	3"	774,65
52091031-100	5200105	275	153	275	122	4"	1.154,00

- Actuadores neumáticos ATEX
Pneumatic actuators ATEX
- Los actuadores neumáticos están calculados en base a una presión de aire de entrada de 6 Bares
Pneumatic actuators are calculated based on a inlet air pressure of 6 Bar

ACTUADOR ELÉCTRICO BAJO VOLTAJE ELECTRIC ACTUATOR LOW VOLTAGE



CÓDIGO	ACTUADOR	H	F	A	G	MEDIDA	€
CODE	ACTUATOR	H	F	A	G	SIZE	€
53291031-015	5324020	216	169	181	110	1/2"	430,29
53291031-020	5324020	223	169	181	110	3/4"	448,95
53291031-025	5324020	229	169	181	110	1"	464,47
53291031-032	5324020	241	169	181	110	1 1/4"	509,13
53291031-040	5324035	247	169	181	110	1 1/2"	651,16
53291031-050	5324035	254	169	181	110	2"	711,28
53291031-065	5324055	301	196	181	110	2 1/2"	928,71
53291031-080	5324085	311	196	181	128	3"	1.276,47
53291031-100	5324140	376	254	235	214	4"	1.617,49

- 12V VAC/VDC

ACTUADOR ELÉCTRICO ALTO VOLTAJE ELECTRIC ACTUATOR HIGH VOLTAGE



CÓDIGO	ACTUADOR	H	F	A	G	MEDIDA	€
CODE	ACTUATOR	H	F	A	G	SIZE	€
53091031-015	5300020	216	169	181	110	1/2"	430,29
53091031-020	5300020	223	169	181	110	3/4"	448,95
53091031-025	5300020	229	169	181	110	1"	464,47
53091031-032	5300020	241	169	181	110	1 1/4"	509,13
53091031-040	5300035	247	169	181	110	1 1/2"	651,16
53091031-050	5300035	254	169	181	110	2"	711,28
53091031-065	5300055	301	196	181	110	2 1/2"	928,71
53091031-080	5300085	311	196	181	128	3"	1.276,47
53091031-100	5300140	376	254	235	214	4"	1.617,49

- 24V-240V VAC/VDC

H ALTURA DESDE EJE DE VÁLVULA A LA PARTE SUPERIOR DEL ACTUADOR / HIGH FROM VALVE AXIS TO ACTUATOR TOP
F ALTURA DEL ACTUADOR / ACTUATOR HIGH
A LONGITUD DEL ACTUADOR / ACTUATOR LENGTH
G GROSOR DEL ACTUADOR / ACTUATOR THICKNESS

91032

VÁLVULA DE ESFERA TIPO WAFER CON PLETINA ISO, CAMISA Y ACTUADOR / WAFER BALL VALVE WAFER-TYPE WITH ISO MOUNTING PAD, HEATING CHAMBER AND ACTUATOR

SIMPLE EFECTO SIMPLE RETURN ACTUATOR



CÓDIGO	ACTUADOR	H	F	A	G	MEDIDA	€
CODE	ACTUATOR	H	F	A	G	SIZE	€
51091032-015	5100052	139	92	145	71	1/2"	412,58
51091032-020	5100052	146	92	145	71	3/4"	444,07
51091032-025	5100075	180	120	201	94	1"	587,60
51091032-032	5100075	192	120	201	94	1 1/4"	649,35
51091032-040	5100083	206	128	209	101	1 1/2"	725,35
51091032-050	5100092	225	140	242	108,5	2"	877,14
51091032-065	5100105	258	153	275	122	2 1/2"	1.099,69
51091032-080	5100125	290	175	332	137,5	3"	1.486,29
51091032-100	5100140	313,5	191,5	385	153	4"	1.910,87

- Actuadores neumáticos ATEX
Pneumatic actuators ATEX
- Los actuadores neumáticos están calculados en base a una presión de aire de entrada de 6 Bares
Pneumatic actuators are calculated based on a inlet air pressure of 6 Bar

DOBLE EFECTO DOUBLE ACTING ACTUATOR



CÓDIGO	ACTUADOR	H	F	A	G	MEDIDA	€
CODE	ACTUATOR	H	F	A	G	SIZE	€
52091032-015	5200052	139	92	145	71	1/2"	394,40
52091032-020	5200052	146	92	145	71	3/4"	425,89
52091032-025	5200052	152	92	145	71	1"	478,73
52091032-032	5200052	164	92	145	71	1 1/4"	540,47
52091032-040	5200063	186	108	169	82	1 1/2"	622,00
52091032-050	5200063	193	108	169	82	2"	699,25
52091032-065	5200075	225	120	201	94	2 1/2"	853,55
52091032-080	5200083	243	128	209	101	3"	1.125,60
52091032-100	5200105	275	153	275	122	4"	1.448,36

- Actuadores neumáticos ATEX
Pneumatic actuators ATEX
- Los actuadores neumáticos están calculados en base a una presión de aire de entrada de 6 Bares
Pneumatic actuators are calculated based on a inlet air pressure of 6 Bar

ACTUADOR ELÉCTRICO BAJO VOLTAJE ELECTRIC ACTUATOR LOW VOLTAGE



CÓDIGO	ACTUADOR	H	F	A	G	MEDIDA	€
CODE	ACTUATOR	H	F	A	G	SIZE	€
53291032-015	5324020	216	169	181	110	1/2"	622,91
53291032-020	5324020	223	169	181	110	3/4"	654,40
53291032-025	5324020	229	169	181	110	1"	712,73
53291032-032	5324020	241	169	181	110	1 1/4"	774,47
53291032-040	5324035	247	169	181	110	1 1/2"	933,64
53291032-050	5324035	254	169	181	110	2"	1.010,88
53291032-065	5324055	301	196	181	110	2 1/2"	1.224,46
53291032-080	5324085	311	196	181	128	3"	1.627,42
53291032-100	5324140	376	254	235	214	4"	2.015,53

- 12V VAC/VDC

ACTUADOR ELÉCTRICO ALTO VOLTAJE ELECTRIC ACTUATOR HIGH VOLTAGE



CÓDIGO	ACTUADOR	H	F	A	G	MEDIDA	€
CODE	ACTUATOR	H	F	A	G	SIZE	€
53091032-015	5300020	216	169	181	110	1/2"	622,91
53091032-020	5300020	223	169	181	110	3/4"	654,40
53091032-025	5300020	229	169	181	110	1"	712,73
53091032-032	5300020	241	169	181	110	1 1/4"	774,47
53091032-040	5300035	247	169	181	110	1 1/2"	933,64
53091032-050	5300035	254	169	181	110	2"	1.010,88
53091032-065	5300055	301	196	181	110	2 1/2"	1.224,46
53091032-080	5300085	311	196	181	128	3"	1.627,42
53091032-100	5300140	376	254	235	214	4"	2.015,53

- 24V-240V VAC/VDC

H ALTURA DESDE EJE DE VÁLVULA A LA PARTE SUPERIOR DEL ACTUADOR / HIGH FROM VALVE AXIS TO ACTUATOR TOP
F ALTURA DEL ACTUADOR / ACTUATOR HIGH
A LONGITUD DEL ACTUADOR / ACTUATOR LENGTH
G GROSOR DEL ACTUADOR / ACTUATOR THICKNESS

APLICACIONES

Uniones para tuberías y sistemas rígidos. Absorbe las vibraciones, dilataciones y contracciones de las instalaciones para proteger los componentes de los esfuerzos derivados del funcionamiento de los equipos.

APLICATIONS

Joints for pipes and rigid systems. Absorbs the vibrations, expansions and contractions of the facilities to protect the components from the efforts derived from the operation of the equipment.



LÍMITES TÉCNICOS

Presión nominal:
16 Bar
Presión de rotura:
30-45 Bar
Temperatura de trabajo:
5121: -20°C / 120°C
51212: -20°C / 80°C
Presión al vacío:
0.56 Bar

TECHNICAL LIMITS

Working pressure:
16 Bar
Bursting pressure:
30-45 Bar
Working temperature:
5121: -20°C / 120°C
51212: -20°C / 80°C
Vacuum pressure:
0.56 Bar

NORMAS DE FABRICACIÓN

Dimensiones bridas bajo norma:
EN-1092 PN-10 PN-16
de DN50 hasta DN150
EN-1092 PN-16
de DN200 hasta DN400
5121 caucho EPDM
51212 caucho NBR

MANUFACTURING STANDARDS

Flange drills according to:
EN-1092 PN-10 PN-16
from DN50 to DN150
EN-1092 PN-16
from DN200 to DN400
5121 EPDM rubber
51212 NBR rubber

MANGUITOS ELÁSTICOS

RUBBER EXPANSION JOINT

**LEYENDA DE ICONOS**
ICON KEY

Posibles codificaciones
aplicadas en esta sección.

Possible encodings applied
in this section.

Recambios
Spare parts

PROPIEADES DE PRODUCTO
PRODUCT PROPERTIES

5120

51202

MANGUITO ELÁSTICO DOBLE ONDA
RUBBER EXPANSION JOINT DOUBLE SPHERE

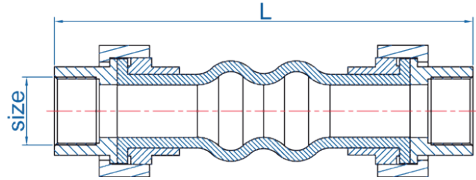

- Tuercas de acero al carbono galvanizado
Nuts made of galvanized carbon steel
- Cuerpo de elastómero EPDM (Ref. 5120) o NBR (Ref.51202)
EPDM (Ref.5120) or NBR (Ref.51202) rubber body
- Tejido interior de poliamida 6
Polyamide 6 inner fabric
- Roscas BSPT según norma ISO 228/1
BSPT threads under ISO228/1
- Presión nominal de trabajo: 16 Bar
Working pressure: 16 Bar

- Presión de rotura: 30 Bar
Bursting pressure: 30 Bar
- Temperatura de trabajo: -20°C / 120°C (Ref.5120)
-20°C / 80°C (Ref.51202)
Working temperature: -20°C / 120°C (Ref.5120)
-20°C / 80°C (Ref.51202)
- Trabajo en vacío: 0.53 Bar
Vacuum pressure: 0.53 Bar

5120 CUERPO EPDM EPDM BODY

CÓDIGO	MEDIDA	L	€
CODE	SIZE	L	€
5120-020	3/4"	200	19,88
5120-025	1"	200	24,29
5120-032	1 1/4"	200	27,99
5120-040	1 1/2"	200	36,04
5120-050	2"	200	45,11
5120-065	2 1/2"	240	69,69

51202 CUERPO NBR NBR BODY

CÓDIGO	MEDIDA	L	€
CODE	SIZE	L	€
51202-020	3/4"	200	21,04
51202-025	1"	200	25,75
51202-032	1 1/4"	200	29,66
51202-040	1 1/2"	200	38,19
51202-050	2"	200	47,61
51202-065	2 1/2"	240	73,85

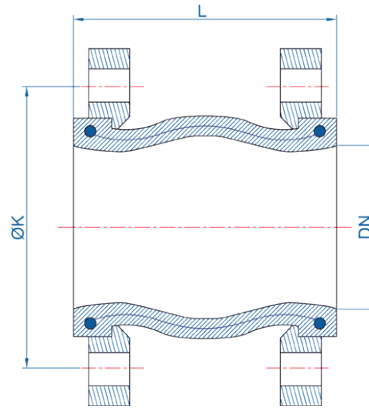
5121
51212MANGUITO ELÁSTICO SIMPLE ONDA
RUBBER EXPANSION JOINT SINGLE SPHERE

- Bridas de acero al carbono galvanizado
Flanges made of galvanized carbon steel
- Dimensiones bridas bajo norma:
EN-1092 PN-10 PN-16 de DN32 hasta DN150
EN-1092 PN-16 de DN200 hasta DN400
5121 caucho EPDM, 51212 caucho NBR
Flange drills according to:
EN-1092 PN-10 PN-16 from DN32 to DN150
EN-1092 PN-16 from DN200 to DN400
5121 EPDM rubber, 51212 NBR rubber
- Cuerpo de elastómero EPDM (Ref. 5121) o NBR (Ref.51212)
EPDM (Ref.5121) or NBR (Ref.51212) rubber body
- Tejido interior de poliamida 6

- Polyamide 6 inner fabric
- Cable de acero circular
Circular hard steel wire
- Presión nominal de trabajo: 16 Bar
Working pressure: 16 Bar
- 5121-0200 PN- 10
5121-0200 PN- 10
- Presión de rotura: 45 Bar
Bursting pressure: 45 Bar
- Temperatura de trabajo: -20°C / 120°C (Ref.5121)
-20°C / 80°C (Ref.51212)
Working temperature: -20°C / 120°C (Ref.5121)
-20°C / 80°C (Ref.51212)
- Trabajo en vacío: 0.56 Bar
Vacuum pressure: 0.56 Bar

5121 CUERPO EPDM
EPDM BODY

CÓDIGO	MEDIDA	DN	ØK	L	€
CODE	SIZE	DN	ØK	L	€
5121-032	1 1/4"	32	100	95	32,46
5121-040	1 1/2"	40	110	95	34,62
5121-050	2"	50	125	105	42,37
5121-065	2 1/2"	65	145	115	55,78
5121-080	3"	80	160	130	68,49
5121-100	4"	100	180	135	84,03
5121-125	5"	125	210	160	113,69
5121-150	6"	150	240	180	141,22
5121-200	8"	200	295	210	213,26
5121-0200*	8"	200	295	210	213,26
5121-250	10"	250	350	240	355,15
5121-300	12"	300	410	260	466,01
5121-350	14"	350	470	265	584,65
5121-400	16"	400	525	265	677,85

51212 CUERPO NBR
NBR BODY

CÓDIGO	MEDIDA	DN	ØK	L	€
CODE	SIZE	DN	ØK	L	€
51212-032	1 1/4"	32	100	95	34,51
51212-040	1 1/2"	40	110	95	38,20
51212-050	2"	50	125	105	44,91
51212-065	2 1/2"	65	145	115	59,11
51212-080	3"	80	160	130	72,61
51212-100	4"	100	180	135	89,15
51212-125	5"	125	210	160	120,52
51212-150	6"	150	240	180	149,68
51212-200	8"	200	295	210	226,05
51212-250	10"	250	350	240	376,48
51212-300	12"	300	410	260	494,01
51212-350	14"	350	470	265	597,38
51212-400	16"	400	525	265	745,63

PN-10*

5126

RECAMBIO - PASADOR PARA MANGUITOS ELÁSTICOS SIMPLE ONDA
SPARE PART - CONTROL ROD SET ELASTIC JOINTS SINGLE SPHERE



CÓDIGO	MEDIDA		€
CODE	SIZE		€
5126-100	4"	1	74,03
5126-125	5"	1	74,03
5126-150	6"	1	87,33
5126-200	8"	1	100,91
5126-250	10"	1	181,98
5126-300	12"	1	197,66

- Compuesto por: dos soportes triángulo, una varilla roscada, dos tuercas, dos arandelas y dos juntas planas.
Kit: two triangle supports, one threaded rod, two nuts, two washers and two flat gaskets.

ACCESORIO INOXIDABLE BRIDAS

STAINLESS STEEL FITTINGS FLANGES

CALIDAD

Materiales A-304L, A-316L

QUALITY

Materials A-304L, A-316L

NORMAS DE FABRICACIÓN

Partiendo de forja según norma A-182 bridas EN-1092-1 PN-10/PN-16 diámetros desde DN15 a DN1000 para tubo ISO y para tubo MM.

MANUFACTURING STANDARDS

By forging process according to A-182 flanges EN-1092-1 PN-10/PN-16 availability from DN15 to DN1000 suitable for ISO pipe and for MM pipe.



ACC. INOX. BRIDAS

S.S. FITTINGS FLANGES

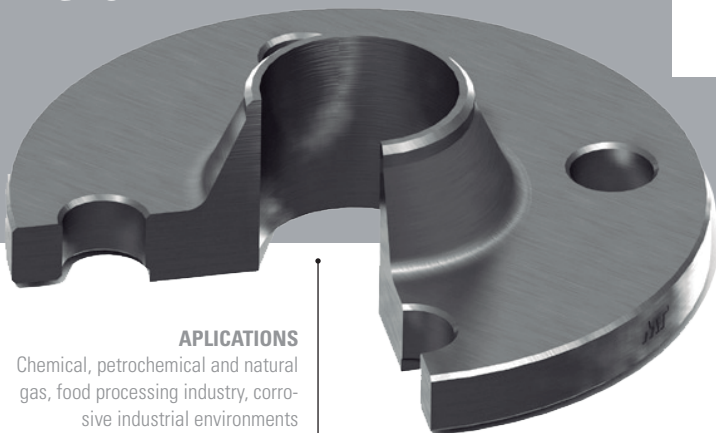
ACC. INOX. BRIDAS
FLANGES S.S. FITTINGS**APLICACIONES**

Industria química, industrias petroquímicas y gas natural
industria alimentaria, entornos industriales de medios corrosivos y temperaturas extremas, ...
Conducción de fluidos, calderas, condensadores, intercambio de calor, reactores, ...

APLICATIONS

Chemical, petrochemical and natural gas, food processing industry, corrosive industrial environments and extreme temperatures ...
Fluid handling, boilers, condensers, heat exchangers, reactors, ...

LEYENDA DE ICONOS**ICON KEY**

Posibles codificaciones aplicadas en esta sección.

Possible encodings applied in this section.

INOXInoxidable
Stainless steelPROPIEDADES DE PRODUCTO
PRODUCT PROPERTIES

FICHA TÉCNICA PARA EN-1092-1 PN-10

TECHNICAL DATA SHEET FOR EN-1092-1 PN-10

DN	PN	TUBO / PIPE		BRIDA / FLANGE			TORNILLOS / BOLTS			PESO / WEIGHT (7,85kg/m ³)	
		d1	d5	D	b	k	nº	ROSCA	d2		
15	40	ISO	21,3	22	95	14	65	4	M12	14	0,67
		MM	18	18,5							0,69
20	40	ISO	26,9	27,5	105	16	75	4	M12	14	0,94
		MM	23	23,5							0,97
25	40	ISO	33,7	34,5	115	16	85	4	M12	14	1,11
		MM	28	28,5							1,16
32	40	ISO	42,4	43,5	140	18	100	4	M16	18	1,62
		MM	38	38,5							1,68
40	40	ISO	48,3	49,5	150	18	110	4	M16	18	1,86
		MM	43	43,5							1,92
50	16	ISO	60,3	61,5	165	20	125	4	M16	18	2,47
		MM	53	53,5							2,59
65	16	ISO	76,1	77,5	185	20	145	8	M16	18	3,00
		MM	73	73,7							3,08
80	16	ISO	88,9	90,5	200	20	160	8	M16	18	3,79
		MM	84	84,7							3,77
100	16	ISO	114,3	116	220	22	180	8	M16	18	4,03
		MM	104	104,8							4,34
125	16	ISO	139,7	141,5	250	22	210	8	M16	18	5,46
		MM	129	130							5,89
150	16	ISO	168,3	170,5	285	24	240	8	M20	22	6,57
		MM	154	156							7,27
200	10	ISO	219,1	221,5	340	24	295	8	M20	22	9,31
		MM	204	206							10,36
250	10	ISO	273	276,5	395	26	350	12	M20	22	11,90
		MM	254	256							13,72
300	10	ISO	323,9	327,5	445	26	400	12	M20	22	13,80
		MM	304	307							15,87
350	10	ISO	355,6	359,5	505	30	460	16	M20	22	20,60
		MM	354	359,5							20,60
400	10	ISO	406,4	411	565	32	515	16	M24	26	27,90
		MM	406	411							27,90
450	10	ISO	457	462,3	615	36	565	20	M24	26	35,60
		MM	457	462,3							35,60
500	10	ISO	508	513,5	670	38	620	20	M24	26	41,10
		MM	508	513,5							41,10
600	10	ISO	610	615	780	42	725	20	M27	30	52,87
		MM	610	615							52,87
700	10	ISO	711	716	895	50	840	24	M27	30	66,48
		MM	711	716							66,48
800	10	ISO	813	818	1015	56	950	24	M30	33	91,82
		MM	813	818							91,82
900	10	ISO	914	920	1115	62	1050	28	M30	33	109,55
		MM	914	920							109,55
1000	10	ISO	1016	1022	1230	70	1160	28	M33	36	134,61
		MM	1016	1022							134,61

BRIDA LISA SOLDAR DIN EN-1092-1 TYPE: 01A PN10

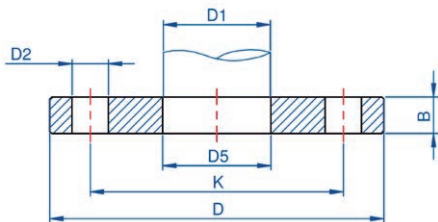

EN 1092-1:2007
TIPO 1 BRIDA PARA SOLDAR
TIPO A CARA PLANA
TYPE 1 PLATE FLANGE FOR WELDING
TYPE A FLAT FACE

EN-1092-1 TYPE:01A
PN-10 MM
EN 1.4307/A-304L

INOX

BRIDA FORJADA LISA SOLDAR EN 1.4307/A-304L
STAINLESS STEEL FORGED FLANGE EN 1.4307/A-304L



EN-1092-1 TYPE:01A
PN-10 MM
EN 1.4404/A-316L

INOX

BRIDA FORJADA LISA SOLDAR EN 1.4404/A-316L
STAINLESS STEEL FORGED FLANGE EN 1.4404/A-316L



CÓDIGO	DN	PN	€
CODE	DN	PN	€
01A61014015	15	40	Consultar
01A61014020	20	40	"
01A61014025	25	40	"
01A61014032	32	40	"
01A61014040	40	40	"
01A61014050	50	16	"
01A61014065	65	16	"
01A61014080	80	16	"
01A61014100	100	16	"
01A61014125	125	16	"
01A61014150	150	16	"
01A10014200	200	10	"
01A10014250	250	10	"
01A10014300	300	10	"
01A10004350	350	10	"
01A10004400	400	10	"
01A10004450	450	10	"
01A10004500	500	10	"
01A10004600	600	10	"
01A10004700	700	10	"
01A10004800	800	10	"
01A10004900	900	10	"
01A10004000	1000	10	"

CÓDIGO	DN	PN	€
CODE	DN	PN	€
01A61016015	15	40	Consultar
01A61016020	20	40	"
01A61016025	25	40	"
01A61016032	32	40	"
01A61016040	40	40	"
01A61016050	50	16	"
01A61016065	65	16	"
01A61016080	80	16	"
01A61016100	100	16	"
01A61016125	125	16	"
01A61016150	150	16	"
01A10016200	200	10	"
01A10016250	250	10	"
01A10016300	300	10	"
01A10006350	350	10	"
01A10006400	400	10	"
01A10006450	450	10	"
01A10006500	500	10	"
01A10006600	600	10	"
01A10006700	700	10	"
01A10006800	800	10	"
01A10006900	900	10	"
01A10006000	1000	10	"

EN-1092-1 TYPE:01A
PN-10 ISO
EN 1.4307/A-304L

INOX

BRIDA FORJADA LISA SOLDAR
EN 1.4307/A-304L
STAINLESS STEEL FORGED
FLANGE
EN 1.4307/A-304L



CÓDIGO	DN	PN	€
CODE	DN	PN	€
01A61024015	15	40	Consultar
01A61024020	20	40	"
01A61024025	25	40	"
01A61024032	32	40	"
01A61024040	40	40	"
01A61024050	50	16	"
01A61024065	65	16	"
01A61024080	80	16	"
01A61024100	100	16	"
01A61024125	125	16	"
01A61024150	150	16	"
01A10024200	200	10	"
01A10024250	250	10	"
01A10024300	300	10	"
01A10004350	350	10	"
01A10004400	400	10	"
01A10004450	450	10	"
01A10004500	500	10	"
01A10004600	600	10	"
01A10004700	700	10	"
01A10004800	800	10	"
01A10004900	900	10	"
01A10004000	1000	10	"

EL TUBO (ISO O MM) SE INTRODUCE EN LA BRIDA HASTA TOPE Y SE REALIZA UNA SOLDADURA POR EL EXTERIOR.
ATENCIÓN: EL MATERIAL DE APORTACIÓN DE LA SOLDADURA TIENE QUE SER COMPATIBLE CON EL DE LA BRIDA.
LA BRIDA PLANA SE USA EN TODO TIPO DE APLICACIONES.
PRECAUCIÓN EN CASO DE POSIBLE FLEXIÓN DE LA TUBERÍA.

EN-1092-1 TYPE:01A
PN-10 ISO
EN 1.4404/A-316L

INOX

BRIDA FORJADA LISA SOLDAR
EN 1.4404/A-316L
STAINLESS STEEL FORGED
FLANGE
EN 1.4404/A-316L



CÓDIGO	DN	PN	€
CODE	DN	PN	€
01A61026015	15	40	Consultar
01A61026020	20	40	"
01A61026025	25	40	"
01A61026032	32	40	"
01A61026040	40	40	"
01A61026050	50	16	"
01A61026065	65	16	"
01A61026080	80	16	"
01A61026100	100	16	"
01A61026125	125	16	"
01A61026150	150	16	"
01A10026200	200	10	"
01A10026250	250	10	"
01A10026300	300	10	"
01A10006350	350	10	"
01A10006400	400	10	"
01A10006450	450	10	"
01A10006500	500	10	"
01A10006600	600	10	"
01A10006700	700	10	"
01A10006800	800	10	"
01A10006900	900	10	"
01A10006000	1000	10	"

THE PIPE (ISO OR MM) IS INSERTED INTO THE FLANGE UNTIL STOP AND WELDING IS PERFORMED FROM OUTSIDE.
NOTE: THE MATERIAL OF THE WELDING FILLER MUST BE COMPATIBLE WITH THE FLANGE MATERIAL.
THE FLAT FLANGE IS USED IN ALL TYPES OF APPLICATIONS.
CAUTION IN CASE OF PIPE BENDING.

BRIDA ROSCADA
EN-1092-1
TYPE: 13B PN-16
THREADED FLANGE
EN-1092-1
TYPE: 13B PN-16

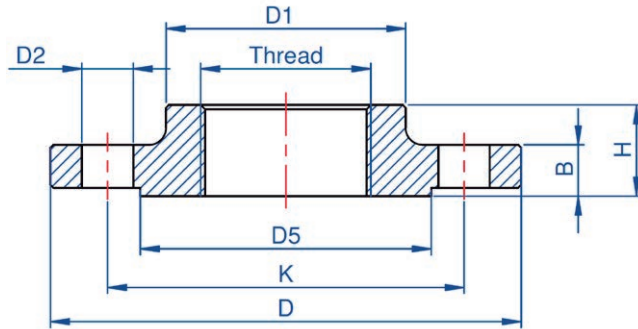

ROSCA		DIMENSIONES / DIMENSIONS						TORNILLOS / BOLTS		
DN	PN	THREAD	D	b	k	N	C	Nº	ROSCA / THREAD	d2
15	40	1/2"	95	22	65	35	16	4	M12	14
20	40	3/4"	105	26	75	45	18	4	M12	14
25	40	1"	115	28	85	52	18	4	M12	14
32	40	1 1/4"	140	30	100	60	18	4	M16	18
40	40	1 1/2"	150	32	110	70	18	4	M16	18
50	16	2"	165	28	125	84	18	4	M16	18
65	16	2 1/2"	185	32	145	104	18	8 (4)	M16	18
80	16	3"	200	34	160	118	20	8	M16	18
100	16	4"	220	40	180	140	20	8	M16	18

EN-1092-1 TYPE:13B
EN 1.4307/A-304L

INOX

BRIDA ROSCADA
EN 1.4307/A-304L
THREADED FLANGE
EN 1.4307/A-304L



EN-1092-1 TYPE:13B
EN 1.4404/A-316L

INOX

BRIDA ROSCADA
EN 1.4404/A-316L
THREADED FLANGE
EN 1.4404/A-316L



CÓDIGO	DN	PN	ROSCA	€
CODE	DN	PN	THREAD	€
13B61054015	15	40	1/2"	Consultar
13B61054020	20	40	3/4"	"
13B61054025	25	40	1"	"
13B61054032	32	40	1 1/4"	"
13B61054040	40	40	1 1/2"	"
13B61054050	50	16	2"	"
13B61054065	65	16	2 1/2"	"
13B61054080	80	16	3"	"
13B61054100	100	16	4"	"

CÓDIGO	DN	PN	ROSCA	€
CODE	DN	PN	THREAD	€
13B61056015	15	40	1/2"	Consultar
13B61056020	20	40	3/4"	"
13B61056025	25	40	1"	"
13B61056032	32	40	1 1/4"	"
13B61056040	40	40	1 1/2"	"
13B61056050	50	16	2"	"
13B61056065	65	16	2 1/2"	"
13B61056080	80	16	3"	"
13B61056100	100	16	4"	"

BRIDA FORJADA LISA SOLDAR EN-1092 TYPE 01A PN-16
STAINLESS STEEL FORGED FLANGE EN-1092 TYPE 01A PN-16

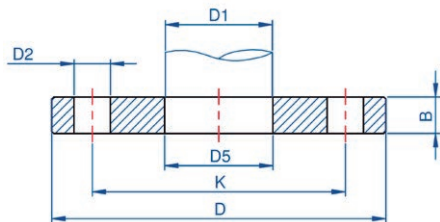

EN 1092-1:2007
TIPO 1 BRIDA PARA SOLDAR
TIPO A CARA PLANA
TYPE 1 PLATE FLANGE FOR WELDING
TYPE A FLAT FACE T

EN-1092-1 TYPE:01A
PN-16 MM
EN 1.4307/A-304L

INOX

BRIDA FORJADA LISA SOLDAR EN 1.4307/A-304L
STAINLESS STEEL FORGED FLANGE EN 1.4307/A-304L



CÓDIGO	DN	PN	€
CODE	DN	PN	€
01A61014015	15	40	Consultar
01A61014020	20	40	"
01A61014025	25	40	"
01A61014032	32	40	"
01A61014040	40	40	"
01A61014050	50	16	"
01A61014065	65	16	"
01A61014080	80	16	"
01A61014100	100	16	"
01A61014125	125	16	"
01A61014150	150	16	"
01A16014200	200	16	"
01A16014250	250	16	"
01A16014300	300	16	"
01A16004350	350	16	"
01A16004400	400	16	"
01A16004500	500	16	"
01A16004600	600	16	"
01A16004700	700	16	"
01A16004800	800	16	"

EN-1092-1 TYPE:01A
PN-16 MM
EN 1.4404/A-316L

INOX

BRIDA FORJADA LISA SOLDAR EN 1.4404/A-316L
STAINLESS STEEL FORGED FLANGE EN 1.4404/A-316L



CÓDIGO	DN	PN	€
CODE	DN	PN	€
01A61016015	15	40	Consultar
01A61016020	20	40	"
01A61016025	25	40	"
01A61016032	32	40	"
01A61016040	40	40	"
01A61016050	50	16	"
01A61016065	65	16	"
01A61016080	80	16	"
01A61016100	100	16	"
01A61016125	125	16	"
01A61016150	150	16	"
01A16016200	200	16	"
01A16016250	250	16	"
01A16016300	300	16	"
01A16006350	350	16	"
01A16006400	400	16	"
01A16006500	500	16	"
01A16006600	600	16	"
01A16006700	700	16	"
01A16006800	800	16	"

EN-1092-1 TYPE:01A
PN-16 ISO
EN 1.4307/A-304L

INOX

BRIDA FORJADA LISA SOLDAR
EN 1.4307/A-304L
STAINLESS STEEL FORGED
FLANGE EN 1.4307/A-304L



CÓDIGO	DN	PN	€
CODE	DN	PN	€
01A61024015	15	40	Consultar
01A61024020	20	40	"
01A61024025	25	40	"
01A61024032	32	40	"
01A61024040	40	40	"
01A61024050	50	16	"
01A61024065	65	16	"
01A61024080	80	16	"
01A61024100	100	16	"
01A61024125	125	16	"
01A61024150	150	16	"
01A16024200	200	16	"
01A16024250	250	16	"
01A16024300	300	16	"
01A16004350	350	16	"
01A16004400	400	16	"
01A16004500	500	16	"
01A16004600	600	16	"
01A16004700	700	16	"
01A16004800	800	16	"

EL TUBO (ISO O MM) SE INTRODUCE EN LA BRIDA HASTA TOPE Y SE REALIZA UNA SOLDADURA POR EL EXTERIOR. ATENCIÓN: EL MATERIAL DE APORTACIÓN DE LA SOLDADURA TIENE QUE SER COMPATIBLE CON EL DE LA BRIDA. LA BRIDA PLANA SE USA EN TODO TIPO DE APLICACIONES, PRECAUCIÓN EN CASO DE POSIBLE FLEXIÓN DE LA TUBERÍA.

EN-1092-1 TYPE:01A
PN-16 ISO
EN 1.4404/A-316L

INOX

BRIDA FORJADA LISA SOLDAR
EN 1.4404/A-316L
STAINLESS STEEL FORGED FLANGE
EN 1.4404/A-316L



CÓDIGO	DN	PN	€
CODE	DN	PN	€
01A61026015	15	40	Consultar
01A61026020	20	40	"
01A61026025	25	40	"
01A61026032	32	40	"
01A61026040	40	40	"
01A61026050	50	16	"
01A61026065	65	16	"
01A61026080	80	16	"
01A61026100	100	16	"
01A61026125	125	16	"
01A61026150	150	16	"
01A16026200	200	16	"
01A16026250	250	16	"
01A16026300	300	16	"
01A16006350	350	16	"
01A16006400	400	16	"
01A16006500	500	16	"
01A16006600	600	16	"
01A16006700	700	16	"
01A16006800	800	16	"

THE PIPE (ISO OR MM) IS INSERTED INTO THE FLANGE UNTIL STOP AND WELDING IS PERFORMED FROM OUTSIDE. NOTE: THE MATERIAL OF THE WELDING FILLER MUST BE COMPATIBLE WITH THE FLANGE MATERIAL. THE FLAT FLANGE IS USED IN ALL TYPES OF APPLICATIONS, PRECAUTION IN CASE OF PIPE BENDING.

EN-1092-1 TYPE:05A
PN-10
EN 1.4307/A-304L

INOX

BRIDA CIEGA A-304L
BLIND FLANGE A-304L



CÓDIGO	DN	PN	€
CODE	DN	PN	€
05A61044015	15	40	Consultar
05A61044020	20	40	"
05A61044025	25	40	"
05A61044032	32	40	"
05A61044040	40	40	"
05A61044050	50	16	"
05A61044065	65	16	"
05A61044080	80	16	"
05A61044100	100	16	"
05A61044125	125	16	"
05A61044150	150	16	"
05A10044200	200	10	"
05A10044250	250	10	"
05A10044300	300	10	"
05A10044350	350	10	"
05A10044400	400	10	"
05A10044450	450	10	"
05A10044500	500	10	"
05A10044600	600	10	"

EN-1092-1 TYPE:05A
PN-10
EN 1.4404/A-316L

INOX

BRIDA CIEGA A-316L
BLIND FLANGE A-316L



CÓDIGO	DN	PN	€
CODE	DN	PN	€
05A61046015	15	40	Consultar
05A61046020	20	40	"
05A61046025	25	40	"
05A61046032	32	40	"
05A61046040	40	40	"
05A61046050	50	16	"
05A61046065	65	16	"
05A61046080	80	16	"
05A61046100	100	16	"
05A61046125	125	16	"
05A61046150	150	16	"
05A10046200	200	10	"
05A10046250	250	10	"
05A10046300	300	10	"
05A10046350	350	10	"
05A10046400	400	10	"
05A10046450	450	10	"
05A10046500	500	10	"
05A10046600	600	10	"

EN-1092-1 TYPE:05A PN-16 EN 1.4404/A-316L

INOX

BRIDA CIEGA A-316L
BLIND FLANGE A-316L

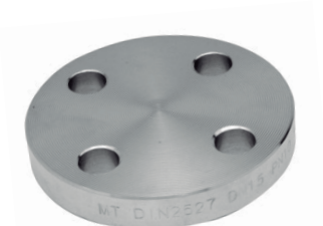

CÓDIGO	DN	PN	€
CODE	DN	PN	€
05A16046200	200	16	"
05A16046250	250	16	"
05A16046300	300	16	"
05A16046350	350	16	"
05A16046400	400	16	"
05A16046500	500	16	"

FICHA TÉCNICA PARA EN-1092-1 TYPE 05A

TECHNICAL DATA SHEET FOR EN-1092-1 TYPE 05A

PN-10

DN	PN	D	b	k	N°	ROSCA	d2	(7,85kg/m ³)
15	40	95	16	65	4	M12	14	0,72
20	40	105	18	75	4	M12	14	1,01
25	40	115	18	85	4	M12	14	1,23
32	40	140	18	100	4	M16	18	1,80
40	40	150	18	110	4	M16	18	2,09
50	16	165	18	125	4	M16	18	2,88
65	16	185	18	145	8	M16	18	3,66
80	16	200	20	160	8	M16	18	4,77
100	16	220	20	180	8	M16	18	5,65
125	16	250	22	210	8	M16	18	8,42
150	16	285	22	240	8	M20	22	10,40
200	10	340	24	295	8	M20	22	16,50
250	10	395	26	350	12	M20	22	24,00
300	10	445	26	400	12	M20	22	30,90
350	10	505	26	460	16	M20	22	40,60
400	10	565	26	515	16	M24	26	49,40
450	10	615	28	565	20	M24	26	63,00
500	10	670	28	620	20	M24	26	75,00
600	10	780	34	725	20	M27	30	110,35

PN-16

DN	PN	D	b	k	N°	ROSCA	d2	(7,85kg/m ³)
200	16	340	24	295	12	M20	22	16,10
250	16	405	26	355	12	M24	26	24,90
300	16	460	28	410	12	M24	26	35,10
350	16	520	30	470	16	M24	26	47,80
400	16	580	32	525	16	M27	30	63,50
500	16	715	44 (36)	650	20	M30	33	102,00

La brida ciega se usa para cerrar finales de tubería, extremos de válvulas, cierres de acumuladores.

En cierres con altas temperaturas y presiones se aconseja que la contrabrida sea de cuello.

The blind flange is used to close the end of pipe, valve ends, tank closures.

A counterflange neck is recommended in closing high temperatures and pressures.

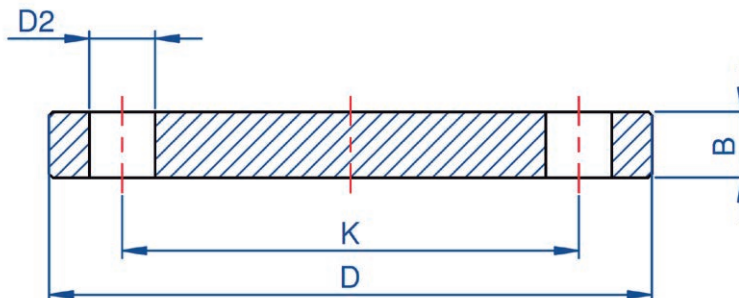

EN-1092-1 TYPE:11B

PN-16

EN 1.4307/A-304L

INOX

BRIDAS CON CUELLO A-304L
WELDING NECK FLANGE A-304L



CÓDIGO	DN	PN	€
CODE	DN	PN	€
11B161024015	15	40	Consultar
11B161024020	20	40	"
11B161024025	25	40	"
11B161024032	32	40	"
11B161024040	40	40	"
11B161024050	50	16	"
11B161024065	65	16	"
11B161024080	80	16	"
11B161024100	100	16	"
11B161024125	125	16	"
11B161024150	150	16	"
11B116024200	200	16	"
11B116024250	250	16	"
11B116024300	300	16	"
11B116024350	350	16	"
11B116024400	400	16	"
11B116024500	500	16	"

- Para tubo ISO
ISO pipes

EN-1092-1 TYPE:11B

PN-16

EN 1.4404/A-316L

INOX

BRIDAS CON CUELLO A-316L
WELDING NECK FLANGE A-316L



CÓDIGO	DN	PN	€
CODE	DN	PN	€
11B161026015	15	40	Consultar
11B161026020	20	40	"
11B161026025	25	40	"
11B161026032	32	40	"
11B161026040	40	40	"
11B161026050	50	16	"
11B161026065	65	16	"
11B161026080	80	16	"
11B161026100	100	16	"
11B161026125	125	16	"
11B161026150	150	16	"
11B116026200	200	16	"
11B116026250	250	16	"
11B116026300	300	16	"
11B116026350	350	16	"
11B116026400	400	16	"
11B116026500	500	16	"

- Para tubo ISO
ISO pipes

FICHA TÉCNICA PARA EN-1092 TYPE 11B

TECHNICAL DATA SHEET FOR EN-1092 TYPE 11B

DN	PN	d1	d3	D	b	k	H	S	h2	d5	f	n	ROSCA	d2	(7,85kg/m3)
15	40	21,3	32	95	16	65	38	2	6	45	2	4	M12	14	0,65
20	40	26,9	40	105	18	75	40	2,3	6	58	2	4	M12	14	0,95
25	40	33,7	50	115	18	85	40	2,6	6	68	2	4	M12	14	1,14
32	40	42,4	60	140	18	100	42	2,6	6	78	2	4	M16	18	1,69
40	40	48,3	70	150	18	110	45	2,6	7	88	3	4	M16	18	1,86
50	16	60,3	84	165	18	125	45	2,9	8	102	3	4	M16	18	2,53
65	16	76,1	104	185	18	145	45	2,9	10	122	3	8	M16	18	3,06
80	16	88,9	120	200	20	160	50	3,2	10	138	3	8	M16	18	3,70
100	16	114,3	140	220	20	180	52	3,6	12	158	3	8	M16	18	4,62
125	16	139,7	170	250	22	210	55	4	12	188	3	8	M16	18	6,30
150	16	168,3	190	285	22	240	55	4,5	12	212	3	8	M20	22	7,75
200	16	219,1	246	340	24	295	62	6,3	16	268	3	12	M20	22	11,00
250	16	273	296	405	26	355	70	6,3	16	320	3	12	M24	26	15,60
300	16	323,9	350	460	28	410	78	7,1	16	378	4	12	M24	26	22,00
350	16	355,6	410	520	30	470	82	8	16	438	4	16	M24	26	31,20
400	16	406,4	458	580	32	525	85	8	16	490	4	16	M27	30	39,30
500	16	508	519	715	36	650	84	8	16	610	4	20	M30	33	61,00

BRIDA FORJADA CON CUELLO DIN EN-1092-1 TYPE 11B PN-16

FORGED NECK FLANGE DIN EN 1092-1 TYPE 11B PN-16

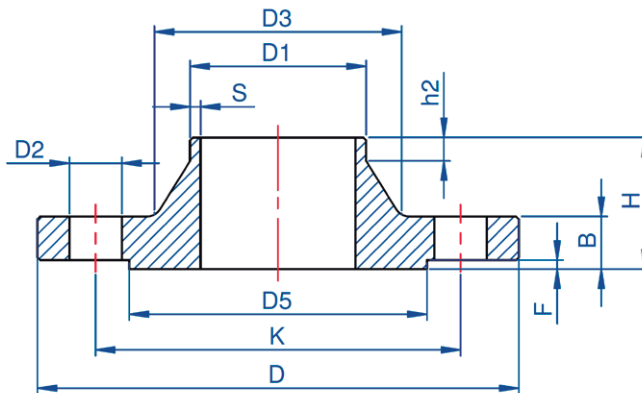

EN 1092-1:2007
TIPO 11 BRIDA CON CUELLO
TIPO B CARA ELEVADA
TYPE 11 WELD-NECK FLANGE
TYPE B RAISED FACE

La brida con cuello se utiliza para condiciones con flexiones. Su forma de cuello consigue una sección interior sin variaciones con la de la tubería, evitando posibles turbulencias.

El tubo (ISO) se presenta a la boca del cuello y se realiza una soldadura por el exterior.

Atención: el material de aportación de la soldadura tiene que ser compatible con el de la brida.

The neck flange is used for bending conditions. Its neck-shaped achieves the section constant with the pipe, preventing possible turbulence.

The tube (ISO) is presented to the mouth of the neck and welding is performed from outside.

Note: the material of the welding filler must be compatible with the flange.

S525604

INOX

VALONA ISO A-304L
SHORT NECK PRESSED
COLLARS ISO A-304L

CÓDIGO	MEDIDA			€
CODE	SIZE			€
S525604015	21.3/2	1	1	1,20
S525604020	26.9/2	1	1	1,50
S525604025	33.7/2	1	1	1,92
S525604032	42.4/2	1	1	2,43
S525604040	48.3/2	1	1	2,96
S525604050	60.3/2	1	1	3,63
S525604065	76.1/2	1	1	4,97
S525604080	88.9/2	1	1	5,21
S525604100	114.3/2	1	1	6,41
S525604125	139.7/2	1	1	7,27
S525604150	168.3/2	1	1	8,47
S525604200	219.1/2	1	1	12,80
S525604250	273.1/2	1	1	16,04
S525604300	323.9/2	1	1	18,70

S525606

INOX

VALONA ISO A-316L
SHORT NECK PRESSED
COLLARS ISO A-316L

CÓDIGO	MEDIDA			€
CODE	SIZE			€
S525606015	21.3/2	1	1	1,28
S525606020	26.9/2	1	1	1,62
S525606025	33.7/2	1	1	2,05
S525606032	42.4/2	1	1	2,60
S525606040	48.3/2	1	1	3,15
S525606050	60.3/2	1	1	3,91
S525606065	76.1/2	1	1	5,32
S525606080	88.9/2	1	1	5,58
S525606100	114.3/2	1	1	6,88
S525606125	139.7/2	1	1	8,91
S525606150	168.3/2	1	1	10,38
S525606200	219.1/2	1	1	15,68
S525606250	273.1/2	1	1	19,63
S525606300	323.9/2	1	1	22,90

FICHA TÉCNICA PARA VALONA ISO

TECHNICAL DATA SHEET FOR COLLARS ISO

DN	DT	e	H	D	D1	D2	PESO WEIGHT
15	1/2"	2	6	43	21,3	17,3	0,024
20	3/4"	2	8	58	26,9	22,9	0,039
25	1"	2	9	68	33,7	29,7	0,053
32	1 1/4"	2	10	78	42,4	38,4	0,070
40	1 1/2"	2	10	88	48,3	44,3	0,085
50	2"	2	12	102	60,3	56,3	0,109
65	2 1/2"	2	12	122	76,1	72,1	0,145
80	3"	2	12	139	88,9	84,9	0,185
100	4"	2	16	158	114,3	110,3	0,207
125	5"	2	16	185	139,7	135,7	0,274
150	6"	2	17	212	168,3	164,3	0,341
200	8"	2	18	270	219,1	215,1	0,482
250	10"	2	18	323	273,0	269,0	0,551
300	12"	2	19	372	323,9	319,9	0,685

VALONA PARA BRIDA DIN/EN-1092

FOR DIN/EN-1092 FLANGE COLLARS

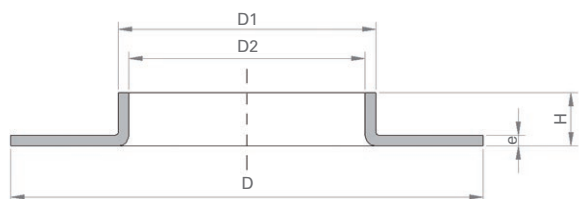

2642024

ISO A-304L

INOX

BRIDA PRENSADA DIN-2642 ISO A-304L
PRESSED FLANGED DIN 2642 ISO A-304L



CÓDIGO CODE	MEDIDA SIZE			€ €
2642024015	1/2"	1	1	6,04
2642024020	3/4"	1	1	6,88
2642024025	1"	1	1	8,16
2642024032	1 1/4"	1	1	11,24
2642024040	1 1/2"	1	1	12,11
2642024050	2"	1	1	14,46
2642024065	2 1/2"	1	1	18,53
2642024080	3"	1	1	20,76
2642024100	4"	1	1	29,86
2642024125	5"	1	1	37,59
2642024150	6"	1	1	56,94
2642024200	8"	1	1	93,45
2642024250	10"	1	1	125,52
2642024300	12"	1	1	156,16

2642026

ISO A-316L

INOX

BRIDA PRENSADA DIN-2642 ISO A-316L
PRESSED FLANGED DIN 2642 ISO A-316L



CÓDIGO CODE	MEDIDA SIZE			€ €
2642026015	1/2"	1	1	7,46
2642026020	3/4"	1	1	8,64
2642026025	1"	1	1	10,38
2642026032	1 1/4"	1	1	14,48
2642026040	1 1/2"	1	1	15,70
2642026050	2"	1	1	18,85
2642026065	2 1/2"	1	1	24,18
2642026080	3"	1	1	27,03
2642026100	4"	1	1	41,26
2642026125	5"	1	1	52,25
2642026150	6"	1	1	80,85
2642026200	8"	1	1	133,82
2642026250	10"	1	1	179,93
2642026300	12"	1	1	224,96

FICHA TÉCNICA PARA 2642

TECHNICAL DATA SHEET FOR 2642

DN	MEDIDA SIZE	PN	TUBO PIPE	d5	D	b	k	e	N	ROSCA THREAD	d2	PESO WEIGHT
15	1/2"	10-16	21,3	25	95	11,5	65	3	4	M12	13,5	0,19
20	3/4"	10-16	26,9	31	105	14	75	3	4	M12	13,5	0,26
25	1"	10-16	33,7	38	115	16	85	3	4	M12	13,5	0,32
32	1 1/4"	10-16	42,4	47	140	16,5	100	3	4	M16	17,5	0,46
40	1 1/2"	10-16	48,3	53	150	17,5	110	3	4	M16	17,5	0,49
50	2"	10-16	60,3	66	165	19,5	125	3	4	M16	17,5	0,60
65	2 1/2"	10-16	76,1	82	185	21	145	3	4	M16	17,5	0,76
80	3"	10-16	88,9	95	200	22	160	3	8	M16	17,5	0,81
100	4"	10-16	114,3	120	220	23	180	4	8	M16	17,5	1,19
125	5"	10-16	139,7	146	250	25	210	4	8	M16	17,5	1,47
150	6"	10-16	168,3	175	295	27	240	5	8	M20	21,5	2,35
200	8"	10	219,1	227	340	31	295	6	8	M20	21,5	3,60
250	10"	10	273	281	395	34	350	6	8	M20	21,5	4,58
300	12"	10	323,9	331	445	38	400	6	8	M20	21,5	5,59

BRIDA PRENSADA 2642

PRESSED FLANGED 2642

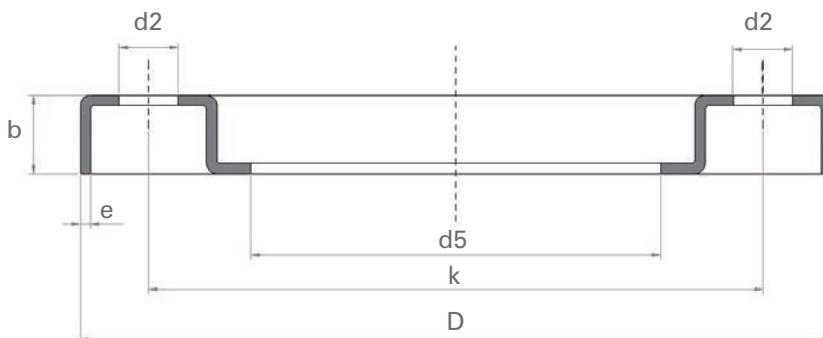

SO1506 ANSI 150 EN 1.4404/A-316L

INOX

BRIDA SLIP-ON A-316L
SLIP ON FLANGE A-316L



CÓDIGO	DN	PSI	€
CODE	DN	PSI	€
SO1506-015	1/2"	150	Consultar
SO1506-020	3/4"	150	"
SO1506-025	1"	150	"
SO1506-032	1 1/4"	150	"
SO1506-040	1 1/2"	150	"
SO1506-050	2"	150	"
SO1506-065	2 1/2"	150	"
SO1506-080	3"	150	"
SO1506-100	4"	150	"
SO1506-125	5"	150	"
SO1506-150	6"	150	"
SO1506-200	8"	150	"
SO1506-250	10"	150	"

WN1506 ANSI 150 EN 1.4404/A-316L

INOX

BRIDA WELDING NECK A-316L
WELDING NECK FLANGE A-316L



CÓDIGO	DN	PSI	€
CODE	DN	PSI	€
WN1506-015	1/2"	150	Consultar
WN1506-020	3/4"	150	"
WN1506-025	1"	150	"
WN1506-032	1 1/4"	150	"
WN1506-040	1 1/2"	150	"
WN1506-050	2"	150	"
WN1506-065	2 1/2"	150	"
WN1506-080	3"	150	"
WN1506-100	4"	150	"
WN1506-125	5"	150	"
WN1506-150	6"	150	"
WN1506-200	8"	150	"
WN1506-250	10"	150	"

BL1506 ANSI 150 EN 1.4404/A-316L

INOX

BRIDA CIEGA A-316L
BLIND FLANGE A-316L



CÓDIGO	DN	PSI	€
CODE	DN	PSI	€
BL1506-015	1/2"	150	Consultar
BL1506-020	3/4"	150	"
BL1506-025	1"	150	"
BL1506-032	1 1/4"	150	"
BL1506-040	1 1/2"	150	"
BL1506-050	2"	150	"
BL1506-065	2 1/2"	150	"
BL1506-080	3"	150	"
BL1506-100	4"	150	"
BL1506-125	5"	150	"
BL1506-150	6"	150	"
BL1506-200	8"	150	"
BL1506-250	10"	150	"

LJ1506 ANSI 150 EN 1.4404/A-316L

INOX

BRIDA LAP JOINT A-316L
LAP JOINT FLANGE A-316L



CÓDIGO	DN	PSI	€
CODE	DN	PSI	€
LJ1506-015	1/2"	150	Consultar
LJ1506-020	3/4"	150	"
LJ1506-025	1"	150	"
LJ1506-032	1 1/4"	150	"
LJ1506-040	1 1/2"	150	"
LJ1506-050	2"	150	"
LJ1506-065	2 1/2"	150	"
LJ1506-080	3"	150	"
LJ1506-100	4"	150	"
LJ1506-125	5"	150	"
LJ1506-150	6"	150	"
LJ1506-200	8"	150	"
LJ1506-250	10"	150	"

SW1506

ANSI 150 1.4404/A-316L

INOX

BRIDA SOCKET WELDING A-316L
SOCKET WELDING FLANGE A-316L



CÓDIGO	DN	PSI	€
CODE	DN	PSI	€
SW1506-015	1/2"	150	Consultar
SW1506-020	3/4"	150	"
SW1506-025	1"	150	"
SW1506-032	1 1/4"	150	"
SW1506-040	1 1/2"	150	"
SW1506-050	2"	150	"
SW1506-065	2 1/2"	150	"
SW1506-080	3"	150	"
SW1506-100	4"	150	"
SW1506-125	5"	150	"
SW1506-150	6"	150	"
SW1506-200	8"	150	"
SW1506-250	10"	150	"

FICHA TÉCNICA

BRIDA ANSI 150 B 16.5

TECHNICAL DATA SHEET ANSI FLANGE 150 B 16.5

BRIDA ANSI BL

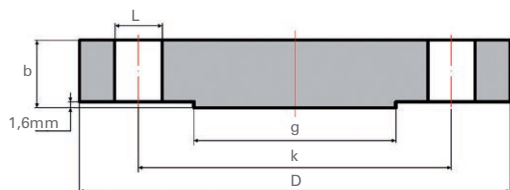

BRIDA ANSI LJ

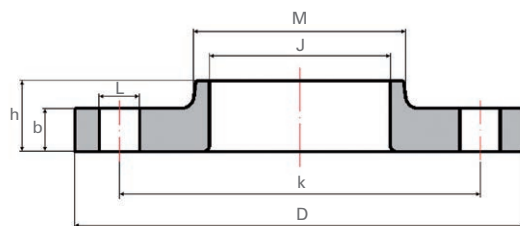

BRIDA ANSI SO

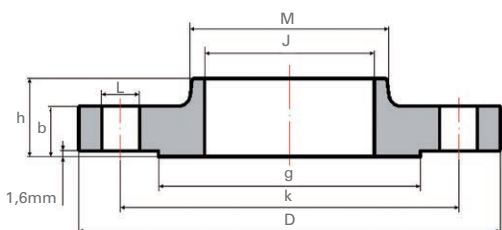

BRIDA ANSI SW

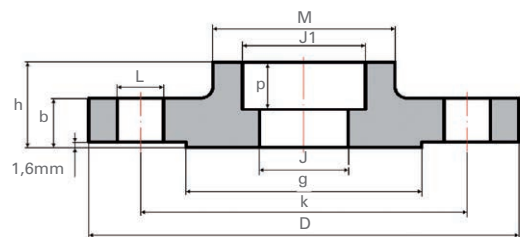

BRIDA ANSI WN

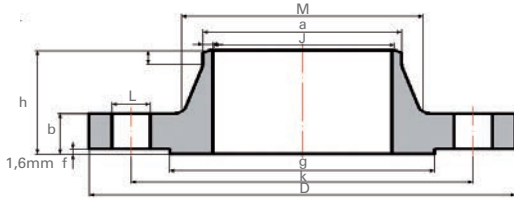

BRIDA / FLANGE						TORNILLOS / BOLTS		
DN	D	b	M	g	k	N	ROSCA	L
1/2	90	11,2	30,2	35,1	60,5	4	1/2	15,7
3/4	100	12,7	38,1	42,9	69,9	4	1/2	15,7
1	110	14,2	49,3	50,8	79,2	4	1/2	15,7
1 1/4	118	15,7	58,7	63,5	88,9	4	1/2	15,7
1 1/2	125	17,5	65	73,2	98,6	4	1/2	15,7
2	150	19,1	77,7	91,9	120,7	4	5/8	19,1
2 1/2	180	22,4	90,4	104,6	139,7	4	5/8	19,1
3	190	23,9	108	127	152,4	4	5/8	19,1
4	230	23,9	134,9	157,2	190,5	8	5/8	19,1
5	254	23,9	163,6	185,7	215,9	8	3/4	22,4
6	280	25,4	192	215,9	241,3	8	3/4	22,4
8	345	28,4	246,1	269,7	298,5	8	3/3	22,4
10	405	30,2	304,8	323,8	361,9	12	7/8	25,4

DN	BLIND	LAP JOINT		SLIP ON				SOCKET WELDING					WELDING NECK			
	Kg	J	h	Kg	J	h	Kg	J	J1	p	h	Kg	J	h	a	Kg
1/2	0,4	22,9	15,7	0,4	22,4	15,7	0,4	22,4	15,7	9,6	15,7	0,4	15,7	47,8	21,3	0,5
3/4	0,7	28,2	15,7	0,7	27,7	15,7	0,7	27,7	20,8	11,1	15,7	0,7	20,8	52,3	26,7	0,7
1	0,9	35,1	17,5	0,8	34,5	17,5	0,8	34,5	26,7	12,7	17,5	0,9	26,7	55,6	33,5	1,1
1 1/4	1,3	43,7	20,6	1,1	43,2	20,6	1,1	43,2	35,1	14,2	20,6	1,2	35,1	57,2	42,2	1,5
1 1/2	1,6	50	22,4	1,4	49,5	22,4	1,4	49,5	40,9	15,7	22,4	1,5	40,9	62	48,3	1,8
2	2,6	62,5	25,4	2,2	62	25,4	2,2	62	52,6	17,5	25,4	2,3	52,6	63,5	60,5	2,7
2 1/2	4,1	75,4	28,4	3,6	74,7	28,4	3,6	74,7	62,7	19	28,4	3,7	62,7	69,9	73,2	4,4
3	5	91,4	30,2	4,1	90,7	30,2	4,1	90,7	78	20,6	30,2	4,2	78	69,9	88,9	5,2
4	7,1	116,8	33,3	5,6	116,1	33,3	5,6	116,1	102,4	23,9	33,3	5,8	102,4	76,2	114,3	7,5
5	9	144,5	36,6	6,3	143,8	36,6	6,3	143,8	128,3	23,9	36,6	6,5	128,3	88,9	141,2	9,2
6	11,8	171,5	39,6	7,5	170,7	39,6	7,5	170,7	154,2	26,9	39,6	7,8	154,2	88,9	168,4	11
8	21	222,3	44,5	12,6	221,5	44,5	12,6	221,5	202,7	31,8	44,5	13,1	202,7	101,6	219,2	18,3
10	31,8	277,4	49,9	19,5	276,3	49,9	19,5	276,4	254,5	33,3	49,9	20,1	254,4	101,6	273	23

ACCESORIO INOXIDABLE ROSCADO

STAINLESS STEEL FITTING THREADED

NORMAS DE FABRICACIÓN

Dimensiones según
Norma ISO 4144

CALIDAD

Austeníticas, tipos:
316-316L

MANUFACTURING STANDARDS

Dimensions according
ISO 4144

QUALITY

Austenitic:
316-316L

APLICACIONES

Chemical, petrochemical and natural gas, food processing, corrosive industrial environments and extreme temperatures ... Fluid handling, boilers, condensers, heat exchangers, reactors, etc.



APLICACIONES

Industria química, industrias petroquímicas y gas natural, industria alimentaria, entornos industriales de medios corrosivos y temperaturas extremas... Conducción de fluidos, calderas, condensadores, intercambio de calor, reactores, etc.

ACC. INOX. ROSCADO

S.S. FITTING - THREADED



TOLERANCIA

DIN 1.4408

TOLERANCE

DIN 1.4408

LÍMITES DE TRABAJO

-20°C to 40°C 20 Bar

100°C 16,5 Bar

150°C 15 Bar

220°C 13,5 Bar

WORK LIMITS

-20°C to 40°C 20 Bar

100°C 16,5 Bar

150°C 15 Bar

220°C 13,5 Bar

LEYENDA DE ICONOS ICON KEY

Posibles codificaciones
aplicadas en esta sección.

Possible encodings applied
in this section.

INOX





Inoxidable Código de barras EAN
Stainless steel EAN bar code

PROPIEDADES DE PRODUCTO
PRODUCT PROPERTIES

8090

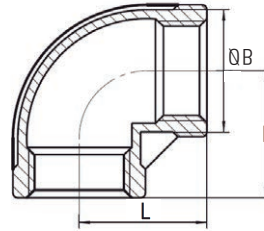
CODO 90° H-H
F-F ELBOW 90°



CÓDIGO	MEDIDA	L	B			€
CODE	SIZE	L	B			€
8090-008	1/4"	19	16,5	400	10	1,35
8090-010	3/8"	23	20	300	10	1,54
8090-015	1/2"	27	24,5	150	10	1,97
8090-020	3/4"	32	30	100	10	2,80
8090-025	1"	38	37,5	60	5	4,59
8090-032	1 1/4"	45	46,5	30	5	7,24
8090-040	1 1/2"	48	53	25	5	8,99
8090-050	2"	57	65,5	10	1	14,54
8090-065	2 1/2"	69	82	6	1	27,48
8090-080	3"	78	95,5	4	1	41,07
8090-100	4"	96	121,5	2	1	67,30

80902

CODO 90° H-H REDUCIDO
F-F REDUCING ELBOW 90°

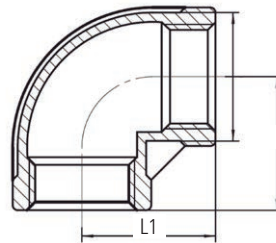

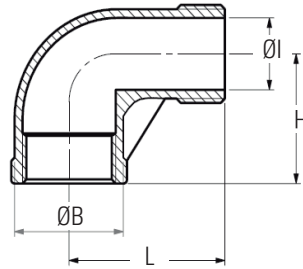

CÓDIGO	MEDIDA	L	L1			€
CODE	SIZE	L	L1			€
80902-02015	3/4" x 1/2"	29	30	100	10	4,62

8092

CODO 90° M-H
M-F ELBOW 90°

INOX



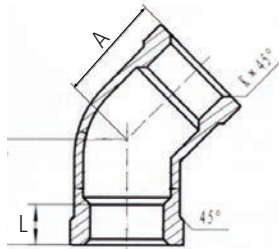

CÓDIGO	MEDIDA	B	H	L	I			€
CODE	SIZE	B	H	L	I			€
8092-006	1/8"	13	17	26	5,5	500	10	1,33
8092-008	1/4"	16,5	19	27	8	400	10	1,72
8092-010	3/8"	19,7	23	29	11,5	350	10	1,82
8092-015	1/2"	24,5	27	35	15	150	10	2,06
8092-020	3/4"	30	32	40	20,5	100	10	3,00
8092-025	1"	37,5	38	46	26	60	5	4,77
8092-032	1 1/4"	46,5	45	54	34,5	40	5	7,57
8092-040	1 1/2"	53	48	57	40	25	5	9,96
8092-050	2"	65,5	57	70	51	10	5	16,10
8092-065	2 1/2"	82	69	83	65,5	6	1	28,09
8092-080	3"	95,5	78	94	77,5	4	1	45,80
8092-100	4"	121,5	97	115	101,5	2	1	76,89

8120

CODO 45° H-H
F-F ELBOW 45°

INOX



CÓDIGO	MEDIDA	A	L	K			€
CODE	SIZE	A	L	K			€
8120-008	1/4"	17	11	1	600	10	1,77
8120-010	3/8"	19	12,5	1	250	10	1,98
8120-015	1/2"	21	11	1,5	150	10	2,03
8120-020	3/4"	25	12	1,5	100	10	3,10
8120-025	1"	29	14	2	60	5	4,39
8120-032	1 1/4"	33	16	2	30	5	6,99
8120-040	1 1/2"	37	17	2	30	5	9,00
8120-050	2"	42	20	2	15	5	12,72

8130

TE 90° H
F TEE 90°

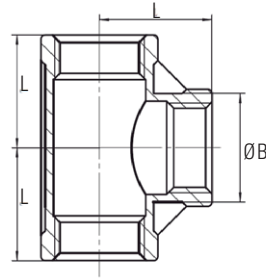

INOX

CÓDIGO	MEDIDA	B	L			€
CODE	SIZE	B	L			€
8130-008	1/4"	16,5	19	400	10	2,04
8130-010	3/8"	20	23	200	10	2,21
8130-015	1/2"	24,5	27	100	10	2,64
8130-020	3/4"	30	32	60	10	3,80
8130-025	1"	37,5	38	40	5	6,15
8130-032	1 1/4"	46,5	45	20	5	9,86
8130-040	1 1/2"	53	48	15	5	12,95
8130-050	2"	65,5	57	10	1	19,23
8130-065	2 1/2"	82	69	4	1	39,23
8130-080	3"	95,5	78	2	1	58,72
8130-100	4"	121,5	96	1	1	96,02

8132

TE REDUCIDA H
F REDUCED TEE

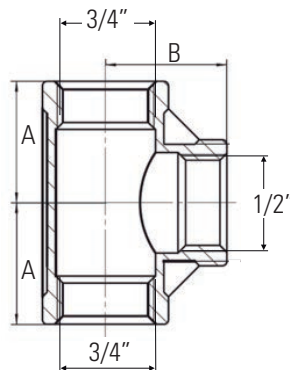

INOX

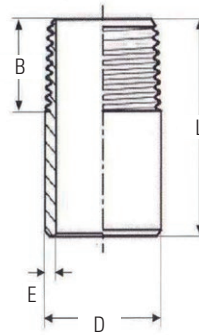

CÓDIGO	MEDIDA	A	B			€
CODE	SIZE	A	B			€
8132-02015	3/4" x 1/2"	29	30	60	10	4,87

8149

ENTRONQUE R-S DE TUBO
M WELD NIPPLE FROM TUBING

INOX



CÓDIGO	MEDIDA	L	B	D	E			€
CODE	SIZE	L	B	D	E			€
8149-008	1/4"	30	13	13,6	2	1000	10	1,02
8149-010	3/8"	30	13	17,2	2	600	10	1,23
8149-015	1/2"	35	16	21,3	2,6	450	10	1,46
8149-020	3/4"	40	16	26,9	2,6	240	10	2,00
8149-025	1"	40	19	33,7	3	140	5	2,47
8149-032	1 1/4"	50	21	42,4	3	70	5	3,33
8149-040	1 1/2"	50	22	48,3	4	60	5	3,91
8149-050	2"	50	26	60,3	3,9	36	1	5,84
8149-065	2 1/2"	60	30	76,1	4,6	18	1	10,43
8149-080	3"	70	34	88,9	5,4	12	1	16,86
8149-100	4"	80	39	114,3	5,7	6	1	25,99

8150

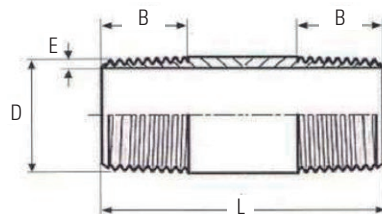
ENTRONQUE ROSCAR M-M DE TUBO
M-M PIPE NIPPLE FROM TUBING

INOX





CÓDIGO	MEDIDA	L	B	D	E			€
CODE	SIZE	L	B	D	E			€
8150-008	1/4"	39	10	13,5	2	500	10	3,54
8150-010	3/8"	41,3	11	17,1	2,2	400	10	3,70
8150-015	1/2"	55	14	21,3	2,9	260	10	4,42
8150-020	3/4"	60	17	26,9	2,9	160	10	4,94
8150-025	1"	60	18	32,6	3,2	100	5	6,49
8150-032	1 1/4"	75	21	42,4	3,2	40	5	8,46
8150-040	1 1/2"	75	24	47	3,2	40	5	9,51
8150-050	2"	90	26	58	3,6	24	5	16,37

8180

INOX 

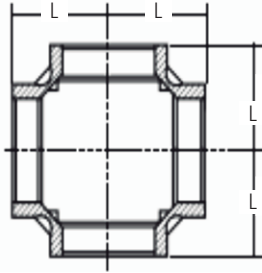
CRUZ
CROSS





CÓDIGO CODE	MEDIDA SIZE	L			€
8180-008	1/4"	19	200	10	3,02
8180-010	3/8"	23	150	10	4,40
8180-015	1/2"	27	80	10	5,66
8180-020	3/4"	32	60	10	8,33
8180-025	1"	38	25	5	13,03
8180-032	1 1/4"	45	20	5	16,96
8180-040	1 1/2"	48	10	5	22,63
8180-050	2"	57	4	1	42,09
8180-065	2 1/2"	69	3	1	64,40
8180-080	3"	78	2	1	81,05
8180-100	4"	96	1	1	138,46

8240

INOX 

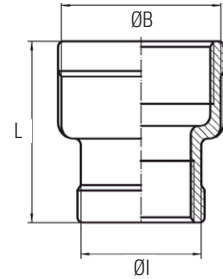

MANGUITO REDUCCIÓN H-H
F-F REDUCED SOCKET

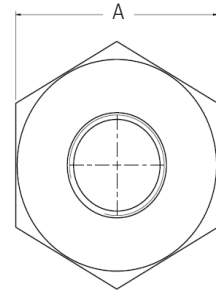
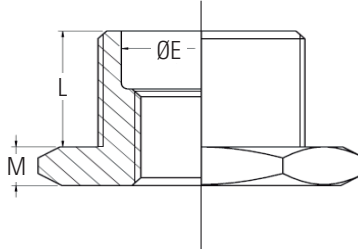

CÓDIGO CODE	MEDIDA SIZE	L	B	I			€
8240-00806	1/4" x 1/8"	25	16,5	13	600	10	1,50
8240-01006	3/8" x 1/8"	26	20	13	500	10	1,63
8240-01008	3/8" x 1/4"	26	20	16,5	500	10	1,73
8240-01506	1/2" x 1/8"	34	24,5	13	350	10	1,95
8240-01508	1/2" x 1/4"	34	24,5	16,5	350	10	1,99
8240-01510	1/2" x 3/8"	34	24,5	20	350	10	2,00
8240-02008	3/4" x 1/4"	36	30	16,5	300	10	2,49
8240-02010	3/4" x 3/8"	36	30	20	300	10	2,49
8240-02015	3/4" x 1/2"	36	30	24,5	200	10	2,58
8240-02508	1" x 1/4"	42	38	17	200	5	3,73
8240-02510	1" x 3/8"	42	38	20,5	200	5	4,24
8240-02515	1" x 1/2"	42	37,5	24,5	200	5	4,55
8240-02520	1" x 3/4"	42	37,5	30	200	5	4,96
8240-03215	1 1/4" x 1/2"	48	49	26	100	5	5,71
8240-03220	1 1/4" x 3/4"	48	46,5	30	100	5	5,72
8240-03225	1 1/4" x 1"	48	46,5	37,5	100	5	5,97
8240-04008	1 1/2" x 1/4"	52	53,5	17	60	5	7,72
8240-04010	1 1/2" x 3/8"	52	54,5	25,5	60	5	7,09
8240-04015	1 1/2" x 1/2"	52	59	26	60	5	7,05
8240-04020	1 1/2" x 3/4"	52	53	30	60	5	7,05
8240-04025	1 1/2" x 1"	52	53	37,5	60	5	7,39
8240-04032	1 1/2" x 1 1/4"	52	53	46,5	50	5	7,21
8240-05025	2" x 1"	58	68,3	39	40	1	10,19
8240-05032	2" x 1 1/4"	58	65,5	46,5	40	1	10,63
8240-05040	2" x 1 1/2"	58	65,5	53	40	1	11,03
8240-06525	2 1/2" x 1"	65	82	48	24	1	21,63
8240-06532	2 1/2" x 1 1/4"	65	84,5	48	24	1	22,37
8240-06540	2 1/2" x 1 1/2"	65	81,5	53	24	1	22,57
8240-06550	2 1/2" x 2"	65	81,5	65,5	24	1	22,97

8241

INOX TUERCA REDUCCIÓN M-H
M-F BUSHING

CÓDIGO	MEDIDA	A	E	L	M			€
CODE	SIZE	A	E	L	M			€
8241-00806	1/4" x 1/8"	14,5	8	10,5	4	1000	10	1,18
8241-01006	3/8" x 1/8"	18,5	11,5	11	5	900	10	1,50
8241-01008	3/8" x 1/4"	18,5	11,5	11	5	900	10	1,57
8241-01506	1/2" x 1/8"	22,5	15	14,5	5	500	10	1,72
8241-01508	1/2" x 1/4"	22,5	15	14,5	5	500	10	1,77
8241-01510	1/2" x 3/8"	22,5	15	14,5	5	500	10	1,82
8241-02008	3/4" x 1/4"	28	20,5	15,5	5,5	350	10	2,30
8241-02010	3/4" x 3/8"	28	20,5	15,5	5,5	350	10	2,33
8241-02015	3/4" x 1/2"	28	20,5	15,5	5,5	350	10	2,43
8241-02508	1" x 1/4"	35	26	18	6	220	5	3,32
8241-02510	1" x 3/8"	35	26	18	6	220	5	3,44
8241-02515	1" x 1/2"	35	26	18	6	220	5	2,88
8241-02520	1" x 3/4"	35	26	18	6	220	5	2,93
8241-03215	1 1/4" x 1/2"	44	34,5	20,5	6,5	120	5	4,63
8241-03220	1 1/4" x 3/4"	44	34,5	20,5	6,5	120	5	4,76
8241-03225	1 1/4" x 1"	44	34,5	20,5	6,5	120	5	4,96
8241-04010	1 1/2" x 3/8"	49,5	20,5	20,5	6,5	90	5	8,60
8241-04015	1 1/2" x 1/2"	49,5	40	20,5	6,5	90	5	9,01
8241-04020	1 1/2" x 3/4"	49,5	40	20,5	6,5	90	5	9,28
8241-04025	1 1/2" x 1"	49,5	40	20,5	6,5	90	5	9,92
8241-04032	1 1/2" x 1 1/4"	49,5	40	20,5	6,5	90	5	10,02
8241-05015	2" x 1/2"	61,5	51	25	7	60	1	10,94
8241-05020	2" x 3/4"	61,5	51	25	7	60	1	11,13
8241-05025	2" x 1"	61,5	51	25	7	60	1	9,56
8241-05032	2" x 1 1/4"	61,5	51	25	7	60	1	10,02
8241-05040	2" x 1 1/2"	61,5	51	25	7	60	1	10,27
8241-06525	2 1/2" x 1"	77,5	51	27	7	24	1	18,51
8241-06540	2 1/2" x 1 1/2"	77,5	65,5	27	7	24	1	19,13
8241-06550	2 1/2" x 2"	77,5	65,5	27	7	24	1	19,33
8241-08040	3" x 1 1/2"	90,5	77,5	30	7,5	20	1	31,38
8241-08050	3" x 2"	90,5	77,5	30	7,5	20	1	24,50
8241-08065	3" x 2 1/2"	90,5	77,5	30	7,5	20	1	25,20
8241-10050	4" x 2"	116,5	77,5	36	8	10	1	42,70
8241-10065	4" x 2 1/2"	116,5	101,5	36	8	10	1	43,62
8241-10080	4" x 3"	116,5	101,5	36	8	10	1	44,22



8245

MACHÓN REDUCIDO M-M
M-M HEXAGON NIPPLE REDUCED

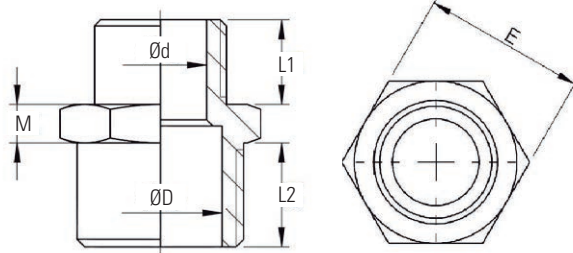



CÓDIGO	MEDIDA	L1	L2	M	D	d	E			€
CODE	SIZE	L1	L2	M	D	d	E			€
8245-00806	1/4" x 1/8"	8	10,5	4	8	5,5	14,5	800	10	1,50
8245-01006	3/8" x 1/8"	8	11	5	11,5	5,5	19	650	10	1,93
8245-01008	3/8" x 1/4"	11	11	5	11,5	8	19	650	10	2,13
8245-01506	1/2" x 1/8"	9	14,5	5	15,5	5,5	23	400	10	2,26
8245-01508	1/2" x 1/4"	11	14,5	5	15	8	23	400	10	2,43
8245-01510	1/2" x 3/8"	11	14,5	5	15	11,5	23	400	10	2,53
8245-02008	3/4" x 1/4"	12	15,5	5,5	21	8	28	300	10	2,73
8245-02010	3/4" x 3/8"	11	15,5	5,5	20,5	11,5	28	300	10	2,78
8245-02015	3/4" x 1/2"	14,5	15,5	5,5	20,5	15	28	300	10	2,93
8245-02508	1" x 1/4"	13,5	19	11	25,5	8	35	200	5	4,69
8245-02510	1" x 3/8"	13,5	18	7,5	26	11,5	35	200	5	3,38
8245-02515	1" x 1/2"	14,5	18	6	26	15	35	200	5	3,74
8245-02520	1" x 3/4"	15,5	18	6,5	26	20,5	35	200	5	3,95
8245-03215	1 1/4" x 1/2"	14,5	20,5	6,5	35	15	44	100	5	6,10
8245-03220	1 1/4" x 3/4"	15,5	20,5	6,5	34,5	20,5	44	100	5	6,17
8245-03225	1 1/4" x 1"	18	20,5	6,5	26	34,5	44	100	5	6,78
8245-04010	1 1/2" x 3/8"	13,5	20,5	6,5	40	12	51	80	5	6,92
8245-04015	1 1/2" x 1/2"	15	20,5	6,5	40	15	51	80	5	6,98
8245-04020	1 1/2" x 3/4"	15,5	20,5	6,5	40	20,5	51	80	5	7,19
8245-04025	1 1/2" x 1"	18	20,5	6,5	40	26	51	80	5	7,29
8245-04032	1 1/2" x 1 1/4"	20,5	20,5	6,5	40	34,5	51	80	5	7,59
8245-05015	2" x 1/2"	13,5	25	7	52	15,5	62	48	1	10,36
8245-05020	2" x 3/4"	15	25	7	52,5	21	62	48	1	9,07
8245-05025	2" x 1"	18	25	7	53	27	62	48	1	9,21
8245-05032	2" x 1 1/4"	20,5	25	7	51	34,5	62	48	1	9,13
8245-05040	2" x 1 1/2"	20,5	25	7	51	40	62	48	1	9,61
8245-06550	2 1/2" x 2"	25	27	7	65,5	51	78	18	1	17,44
8245-08050	3" x 2"	22	32	7,5	76,5	40	90,5	18	1	24,09
8245-08065	3" x 2 1/2"	25	30	8	77,5	51	90,5	18	1	25,00

8270

MANGUITO H-H DE TUBO
F-F SOCKET FROM TUBING

INOX



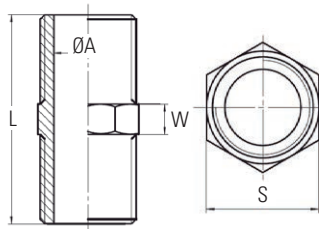

CÓDIGO	MEDIDA	L	D			€
CODE	SIZE	L	D			€
8270-008	1/4"	25	18,5	600	10	1,66
8270-010	3/8"	26	21,3	450	10	1,77
8270-015	1/2"	34	26,6	240	10	2,12
8270-020	3/4"	36	31,8	200	10	2,86
8270-025	1"	43	39,5	100	5	4,45
8270-032	1 1/4"	48	48,3	60	5	6,90
8270-040	1 1/2"	48	54,5	45	5	7,61
8270-050	2"	56	66,2	27	1	11,76
8270-065	2 1/2"	65	82	12	1	24,13
8270-080	3"	71	95	12	1	28,27
8270-100	4"	83	121,4	4	1	47,27

8280

MACHÓN M-M
M-M HEXAGON NIPPLE

INOX



CÓDIGO	MEDIDA	ØA	L	S	W			€
CODE	SIZE	ØA	L	S	W			€
8280-006	1/8"	5,5	28	12	7	1000	10	1,05
8280-008	1/4"	8	25	14	4,5	1000	10	1,19
8280-010	3/8"	11,5	27	18	5,5	600	10	1,45
8280-015	1/2"	15	34	22	5,5	380	10	1,61
8280-020	3/4"	20,5	36,5	28	5,5	200	10	2,27
8280-025	1"	26	42	34	6	180	5	3,51
8280-032	1 1/4"	34,5	47,5	44	6,5	60	5	5,25
8280-040	1 1/2"	40	47,5	50	6,5	50	5	6,59
8280-050	2"	51	57	61,5	7	36	1	9,83
8280-065	2 1/2"	65,5	61	77	7	18	1	19,69
8280-080	3"	77,5	67,5	90	7,5	12	1	26,13
8280-100	4"	103	80	120	8	4	1	37,41

8290

INOX

TAPÓN ROSCA M CON REBORDE
M HEXAGON PLUGS

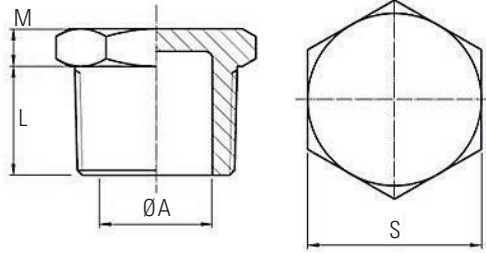

CÓDIGO	MEDIDA	ØA	S	M	L			€
CODE	SIZE	ØA	S	M	L			€
8290-008	1/4"	8	14,5	4	10,5	800	10	0,91
8290-010	3/8"	11,5	18	5	11	600	10	1,02
8290-015	1/2"	15	22	5	14,5	500	10	1,20
8290-020	3/4"	20,5	27,5	5,5	15,5	300	10	1,95
8290-025	1"	26	34,5	6	18	200	5	2,62
8290-032	1 1/4"	34,5	43,5	6,5	20,5	120	5	4,75
8290-040	1 1/2"	40	50,5	6,5	20,5	70	5	6,75
8290-050	2"	51	62,5	7	25	60	1	9,57
8290-065	2 1/2"	65,5	78,5	7	27	24	1	16,04
8290-080	3"	77,5	92	7,5	30	20	1	23,55
8290-100	4"	104	115,5	8	36	8	1	39,58

8300

INOX

TAPÓN HEXAGONAL H
F HEXAGON CAP

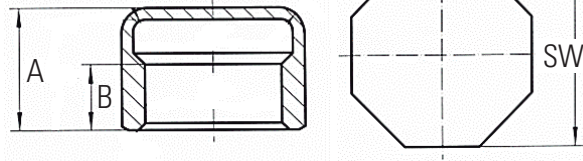
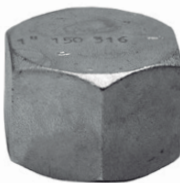

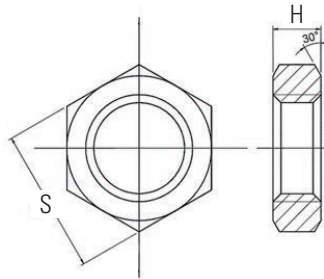

CÓDIGO	MEDIDA	A	B	SW			€
CODE	SIZE	A	B	SW			€
8300-008	1/4"	16	14	16,5	1000	10	0,96
8300-010	3/8"	16,5	11,5	20	800	10	1,08
8300-015	1/2"	21	14,5	24,5	400	10	1,61
8300-020	3/4"	22	17	30	250	10	1,98
8300-025	1"	26	21	37	150	5	3,06
8300-032	1 1/4"	24	18	45,5	80	5	4,89
8300-040	1 1/2"	29	18	53	70	5	5,89
8300-050	2"	33	18	65	40	1	8,74
8300-065	2 1/2"	38	22	82	20	1	18,22
8300-080	3"	38,5	28	100	15	1	31,00
8300-100	4"	48	33	122	8	1	35,83

8312

TUERCA HEXAGONAL
BACK NUT

INOX



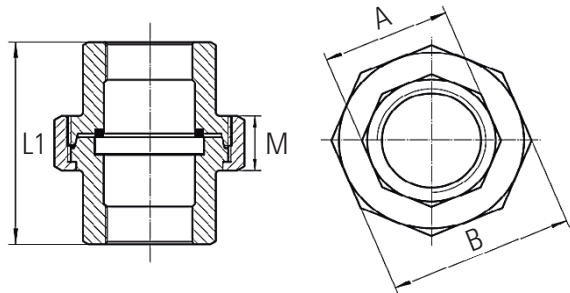

CÓDIGO	MEDIDA	H	S			€
CODE	SIZE	H	S			€
8312-008	1/4"	5,5	18	1000	10	0,88
8312-010	3/8"	6	23,5	1000	10	0,95
8312-015	1/2"	6,5	29,5	600	10	1,12
8312-020	3/4"	7	34	500	10	1,35
8312-025	1"	9	42,5	300	5	1,91
8312-032	1 1/4"	11	52	200	5	2,90
8312-040	1 1/2"	11	58	150	5	3,52
8312-050	2"	13	72	80	1	5,24

8330

ENLACE TRES PIEZAS JUNTA
PLANA PTFE H-H
F-F THREE PIECES UNION PTFE
FLAT SEAT

INOX



CÓDIGO	MEDIDA	A	B	L1	M			€
CODE	SIZE	A	B	L1	M			€
8330-008	1/4"	16,5	29	33,5	13,5	200	10	4,05
8330-010	3/8"	20	34	36,5	15	120	10	4,79
8330-015	1/2"	24,5	37	40	16	100	10	6,07
8330-020	3/4"	30	44	42,5	17	70	10	7,89
8330-025	1"	37	52,5	50	20	40	5	12,00
8330-032	1 1/4"	46,5	64	54	22	30	5	16,16
8330-040	1 1/2"	53	70	58	24	25	5	20,92
8330-050	2"	65	84	65,5	27	15	1	32,30
8330-065	2 1/2"	85	108	75	29,5	8	1	59,86
8330-080	3"	96	118	83	31	6	1	92,45
8330-100	4"	125	152	110	34	3	1	124,03

8340

ENLACE TRES PIEZAS H-H
F-F THREE PIECES UNION

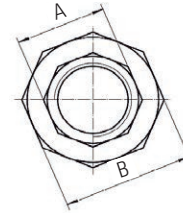
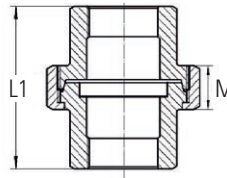

CÓDIGO CODE	MEDIDA SIZE	A A	B B	L1 L1	M M			€ €
8340-008	1/4"	16,5	29	33,5	13,5	200	10	4,48
8340-010	3/8"	20	34	36,5	15	120	10	4,88
8340-015	1/2"	24,5	37	40	16	100	10	5,26
8340-020	3/4"	30	44	42,5	17	70	10	7,06
8340-025	1"	37	52,5	50	20	40	10	10,36
8340-032	1 1/4"	46,5	64	54	22	30	5	14,73
8340-040	1 1/2"	53	70	58	24	25	5	18,89
8340-050	2"	65	84	65,5	27	15	5	27,64
8340-065	2 1/2"	82	101,5	75	29,5	8	1	42,66
8340-080	3"	96	118	83	31	6	1	60,68
8340-100	4"	125	152	90	31,5	3	1	97,96

- Asiento cónico
Tapered seat

8341

ENLACE TRES PIEZAS H-H
M-F THREE PIECES UNION

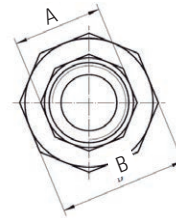
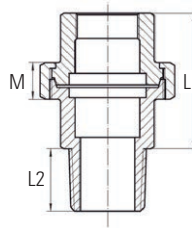

CÓDIGO CODE	MEDIDA SIZE	A A	B B	L1 L1	L2 L2	M M			€ €
8341-008	1/4"	16,5	29	33,5	10,5	13,5	150	10	5,02
8341-010	3/8"	20	34	36,5	11	15	120	10	5,45
8341-015	1/2"	24,5	37	39,5	14,5	16	100	10	6,52
8341-020	3/4"	30	44	42,5	15,5	17	50	10	9,44
8341-025	1"	37	52,5	50	18	20	40	5	13,72
8341-032	1 1/4"	46,5	63	54	20,5	22	20	5	17,49
8341-040	1 1/2"	53	70	58	20,5	24	15	5	21,68
8341-050	2"	65	84	65	25	27	10	1	34,42
8341-065	2 1/2"	82	101,5	75	27	29,5	6	1	57,46
8341-080	3"	95,5	118	83	30	31	3	1	68,07
8341-100	4"	121,5	148,5	110	36	34	2	1	113,98

- Asiento cónico
Tapered seat

8399

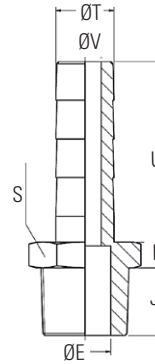
ENTRONQUE MANGUERA
HEXAGON HOSE NIPPLE

INOX



CÓDIGO	MEDIDA	E	J	K	U	V	T	S			€
CODE	SIZE	E	J	K	U	V	T	S			€
8399-008	1/4" x 9	8	10,5	4	28	5	9	15	600	10	2,02
8399-010	3/8" x 11,5	11,5	11	5	33	7	11,5	18,5	500	10	2,08
8399-015	1/2" x 15	16	14	7	27	8,5	15	22	350	10	2,39
8399-020	3/8" x 20	20,5	15,5	5,5	45	15	20	28	150	10	3,64
8399-025	1" x 27	26	18	6	52	22	27	34	100	5	4,93
8399-032	1 1/4" x 33	34,5	20,5	6,5	52	27,5	33	44	50	5	8,37
8399-040	1 1/2" x 40	40	20	6,5	55	34	39	49,5	30	5	10,51
8399-050	2" x 53	51	25	7,5	60	45,5	52	61,5	20	1	14,90

8531

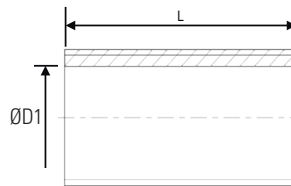
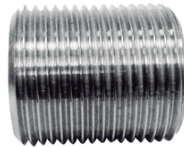
MANGUITO INTERIOR
RUNNING NIPPLE

INOX



CÓDIGO	MEDIDA	ØD1	L			€
CODE	SIZE	ØD1	L			€
8531-008	1/4"	9,5	18	400	10	1,17
8531-010	3/8"	12,2	22	400	10	1,25
8531-015	1/2"	16,6	25	400	10	1,99
8531-020	3/4"	21,5	30	250	10	2,56
8531-025	1"	27	35	100	5	3,76
8531-032	1 1/4"	35,7	38	100	5	5,65
8531-040	1 1/2"	41,2	38	80	5	7,03
8531-050	2"	53	45	20	1	11,11
8531-065	2 1/2"	69,3	51	20	1	17,45
8531-080	3"	80,5	60	10	1	25,40
8531-100	4"	105,3	70	10	1	42,47

8601

ENTRONQUE ROSCA MANGUERA
THREADED HOSE COUPLING

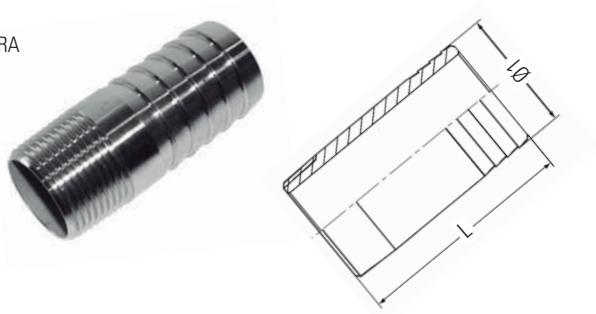

CÓDIGO	MEDIDA	Ø1	L			€
CODE	SIZE	Ø1	L			€
8601-008	1/4"	13,5	70	200	10	2,35
8601-010	3/8"	17,2	70	200	10	2,67
8601-015	1/2"	21,3	70	200	10	3,29
8601-020	3/4"	26,9	70	120	10	4,08
8601-025	1"	33,7	70	50	5	5,39
8601-032	1 1/4"	42,4	70	40	5	6,94
8601-040	1 1/2"	48,3	100	20	5	10,26
8601-050	2"	60,3	100	20	1	13,58

8602

ENTRONQUE DOBLE MANGUERA
HOSE COUPLING

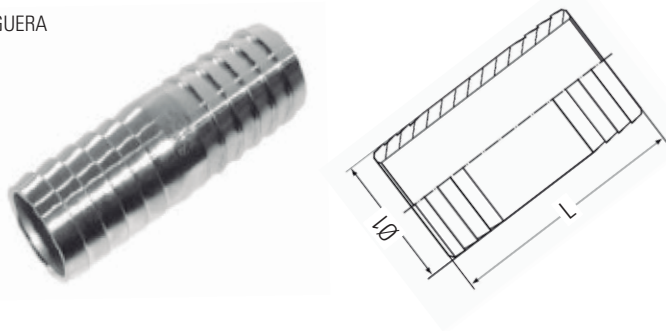

CÓDIGO	MEDIDA	Ø1	L			€
CODE	SIZE	Ø1	L			€
8602-008	1/4"	13,5	66	200	10	2,30
8602-010	3/8"	17,2	76	200	10	2,78
8602-015	1/2"	21,3	86	200	10	3,67
8602-020	3/4"	26,9	100	100	10	5,07
8602-025	1"	33,7	114	50	5	7,46
8602-032	1 1/4"	42,4	114	35	1	9,72
8602-040	1 1/2"	48,3	122	25	1	11,91
8602-050	2"	60,3	130	25	1	16,64

PRODUCTO

Accesorio para soldar SCH10,
SCH40

Procedente de tubo soldado

PRODUCT

Welding fitting SCH10,
SCH40

Fitting from welded pipe

DIMENSIONES

Según ANSI/ASME
B16.9-2007

TOLERANCES

According ANSI/ASME
B16.9-2007

ACCESORIO INOXIDABLE PARA SOLDAR

WELDING FITTING SCHEDULE



PULGADAS	DIÁMETRO EXT. (MM)	ESPEJOR PARED SCH10 (MM)	ESPEJOR PARED SCH40 (MM)
INCHES	DIAMETER EXT. (MM)	WALL THICKNESS SCH10 (MM)	WALL THICKNESS SCH40 (MM)
1/2"	21,34	2,11	2,77
3/4"	26,67	2,11	2,87
1"	33,40	2,77	3,38
1 1/4"	42,16	2,77	3,56
1 1/2"	48,26	2,77	3,68
2"	60,33	2,77	3,91
2 1/2"	73,03	3,05	5,16
3"	88,90	3,05	5,49
4"	114,30	3,05	6,02
5"	141,30	3,40	6,55
6"	168,28	3,40	7,11
8"	219,08	3,76	8,18
10"	273,05	4,19	9,27
12"	323,85	4,57	-

MT[®]
INDUSTRIAL

ACC. INOX. SOLDAR WELDING FITTING SCHEDULE

LEYENDA DE ICONOS**ICON KEY**

Posibles codificaciones
aplicadas en esta sección.

Possible encodings applied
in this section.

INOX

Inoxidable
Stainless steel

PROPIEDADES DE PRODUCTO
PRODUCT PROPERTIES

S09014 SCH 10 A-304L

CODO 90° RADIO LARGO
ELBOW 90° LONG RADIUS

INOX

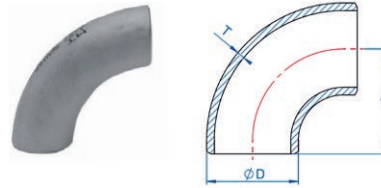

CÓDIGO	MEDIDA	D	T Sch 10	A		€
CODE	SIZE	D	T Sch 10	A		€
S09014-015	1/2"	21,34	2,11	38,1	1	Consultar
S09014-020	3/4"	26,67	2,11	38,1	1	Consultar
S09014-025	1"	33,4	2,77	38,1	1	Consultar
S09014-032	1 1/4"	42,16	2,77	47,75	1	Consultar
S09014-040	1 1/2"	48,26	2,77	57,15	1	Consultar
S09014-050	2"	60,33	2,77	76,2	1	Consultar
S09014-065	2 1/2"	73,03	3,05	95,25	1	Consultar
S09014-080	3"	88,9	3,05	114,3	1	Consultar
S09014-100	4"	114,3	3,05	152,4	1	Consultar
S09014-125	5"	141,3	3,4	190,5	1	Consultar
S09014-150	6"	168,28	3,4	228,6	1	Consultar
S09014-200	8"	219,08	3,76	304,08	1	Consultar
S09014-250	10"	273,05	4,19	381	1	Consultar
S09014-300	12"	323,85	4,57	457,2	1	Consultar

S09016 SCH 10 A-316L

CODO 90° RADIO LARGO
ELBOW 90° LONG RADIUS

INOX

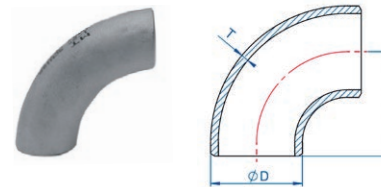

CÓDIGO	MEDIDA	D	T Sch 10	A		€
CODE	SIZE	D	T Sch 10	A		€
S09016-015	1/2"	21,34	2,11	38,1	1	Consultar
S09016-020	3/4"	26,67	2,11	38,1	1	Consultar
S09016-025	1"	33,4	2,77	38,1	1	Consultar
S09016-032	1 1/4"	42,16	2,77	47,75	1	Consultar
S09016-040	1 1/2"	48,26	2,77	57,15	1	Consultar
S09016-050	2"	60,33	2,77	76,2	1	Consultar
S09016-065	2 1/2"	73,03	3,05	95,25	1	Consultar
S09016-080	3"	88,9	3,05	114,3	1	Consultar
S09016-100	4"	114,3	3,05	152,4	1	Consultar
S09016-125	5"	141,3	3,4	190,5	1	Consultar
S09016-150	6"	168,28	3,4	228,6	1	Consultar
S09016-200	8"	219,08	3,76	304,08	1	Consultar
S09016-250	10"	273,05	4,19	381	1	Consultar
S09016-300	12"	323,85	4,57	457,2	1	Consultar

S09046 SCH 40 A-316L

CODO 90° RADIO LARGO
ELBOW 90° LONG RADIUS

INOX

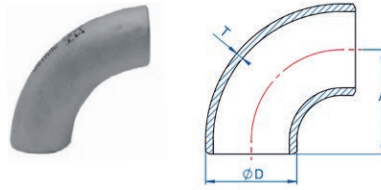

CÓDIGO	MEDIDA	D	T Sch 40	A		€
CODE	SIZE	D	T Sch 40	A		€
S09046-015	1/2"	21,34	2,77	38,1	1	Consultar
S09046-020	3/4"	26,67	2,87	38,1	1	Consultar
S09046-025	1"	33,4	3,38	38,1	1	Consultar
S09046-032	1 1/4"	42,16	3,56	47,75	1	Consultar
S09046-040	1 1/2"	48,26	3,68	57,15	1	Consultar
S09046-050	2"	60,33	3,91	76,2	1	Consultar
S09046-065	2 1/2"	73,03	5,16	95,25	1	Consultar
S09046-080	3"	88,9	5,49	114,3	1	Consultar
S09046-100	4"	114,3	6,02	152,4	1	Consultar
S09046-125	5"	141,3	6,55	190,5	1	Consultar
S09046-150	6"	168,28	7,11	228,6	1	Consultar
S09046-200	8"	219,08	8,18	304,08	1	Consultar
S09046-250	10"	273,05	9,27	381	1	Consultar

S13014 SCH 10 A-304L

TEE
TEE

INOX

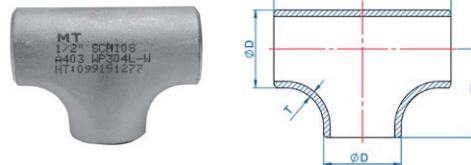

CÓDIGO	MEDIDA	D	T Sch 10	H		€
CODE	SIZE	D	T Sch 10	H		€
S13014-015	1/2"	21,34	2,11	25	1	Consultar
S13014-020	3/4"	26,67	2,11	29	1	Consultar
S13014-025	1"	33,4	2,77	38	1	Consultar
S13014-032	1 1/4"	42,16	2,77	48	1	Consultar
S13014-040	1 1/2"	48,26	2,77	57	1	Consultar
S13014-050	2"	60,33	2,77	64	1	Consultar
S13014-065	2 1/2"	73,03	3,05	75	1	Consultar
S13014-080	3"	88,9	3,05	86	1	Consultar
S13014-100	4"	114,3	3,05	105	1	Consultar
S13014-125	5"	141,3	3,4	124	1	Consultar
S13014-150	6"	168,28	3,4	143	1	Consultar
S13014-200	8"	219,08	3,76	178	1	Consultar
S13014-250	10"	273,05	4,19	216	1	Consultar
S13014-300	12"	323,85	4,57	254	1	Consultar

S13016 SCH 10 A-316L

TE
TEE

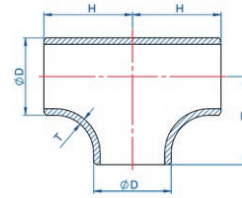

INOX

CÓDIGO	MEDIDA	D	T Sch 10	H		€
CODE	SIZE	D	T Sch 10	H		€
S13016-015	1/2"	21,34	2,11	25	1	Consultar
S13016-020	3/4"	26,67	2,11	29	1	Consultar
S13016-025	1"	33,4	2,77	38	1	Consultar
S13016-032	1 1/4"	42,16	2,77	48	1	Consultar
S13016-040	1 1/2"	48,26	2,77	57	1	Consultar
S13016-050	2"	60,33	2,77	64	1	Consultar
S13016-065	2 1/2"	73,03	3,05	75	1	Consultar
S13016-080	3"	88,9	3,05	86	1	Consultar
S13016-100	4"	114,3	3,05	105	1	Consultar
S13016-125	5"	141,3	3,4	124	1	Consultar
S13016-150	6"	168,28	3,4	143	1	Consultar
S13016-200	8"	219,08	3,76	178	1	Consultar
S13016-250	10"	273,05	4,19	216	1	Consultar
S13016-300	12"	323,85	4,57	254	1	Consultar

S13046 SCH 40 A-316L

TE
TEE

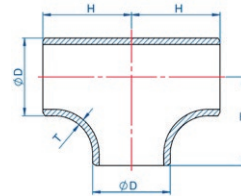



INOX

CÓDIGO	MEDIDA	D	T Sch 40	H		€
CODE	SIZE	D	T Sch 40	H		€
S13046-015	1/2"	21,34	2,77	25	1	Consultar
S13046-020	3/4"	26,67	2,87	29	1	Consultar
S13046-025	1"	33,4	3,38	38	1	Consultar
S13046-032	1 1/4"	42,16	3,56	48	1	Consultar
S13046-040	1 1/2"	48,26	3,68	57	1	Consultar
S13046-050	2"	60,33	3,91	64	1	Consultar
S13046-065	2 1/2"	73,03	5,16	75	1	Consultar
S13046-080	3"	88,9	5,49	86	1	Consultar
S13046-100	4"	114,3	6,02	105	1	Consultar
S13046-125	5"	141,3	6,55	124	1	Consultar
S13046-150	6"	168,28	7,11	143	1	Consultar
S13046-200	8"	219,08	8,18	178	1	Consultar
S13046-250	10"	273,05	9,27	216	1	Consultar

S29014 SCH 10 A-304L

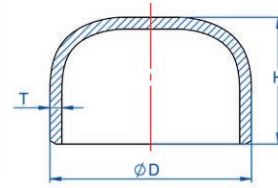
INOX

TAPÓN
CAP

CÓDIGO	MEDIDA	D	T Sch 10	H		€
CODE	SIZE	D	T Sch 10	H		€
S29014-015	1/2"	21,34	2,11	25	1	Consultar
S29014-020	3/4"	26,67	2,11	25	1	Consultar
S29014-025	1"	33,4	2,77	38	1	Consultar
S29014-032	1 1/4"	42,16	2,77	38	1	Consultar
S29014-040	1 1/2"	48,26	2,77	38	1	Consultar
S29014-050	2"	60,33	2,77	38	1	Consultar
S29014-065	2 1/2"	73,03	3,05	38	1	Consultar
S29014-080	3"	88,9	3,05	51	1	Consultar
S29014-100	4"	114,3	3,05	64	1	Consultar
S29014-125	5"	141,3	3,4	76	1	Consultar
S29014-150	6"	168,28	3,4	89	1	Consultar
S29014-200	8"	219,08	3,76	102	1	Consultar
S29014-250	10"	273,05	4,19	127	1	Consultar
S29014-300	12"	323,85	4,57	152	1	Consultar

S29016 SCH 10 A-316L

INOX

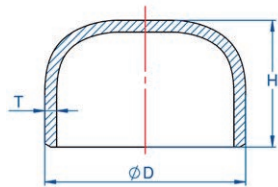
TAPÓN
CAP

CÓDIGO	MEDIDA	D	T Sch 10	H		€
CODE	SIZE	D	T Sch 10	H		€
S29016-015	1/2"	21,34	2,11	25	1	Consultar
S29016-020	3/4"	26,67	2,11	25	1	Consultar
S29016-025	1"	33,4	2,77	38	1	Consultar
S29016-032	1 1/4"	42,16	2,77	38	1	Consultar
S29016-040	1 1/2"	48,26	2,77	38	1	Consultar
S29016-050	2"	60,33	2,77	38	1	Consultar
S29016-065	2 1/2"	73,03	3,05	38	1	Consultar
S29016-080	3"	88,9	3,05	51	1	Consultar
S29016-100	4"	114,3	3,05	64	1	Consultar
S29016-125	5"	141,3	3,4	76	1	Consultar
S29016-150	6"	168,28	3,4	89	1	Consultar
S29016-200	8"	219,08	3,76	102	1	Consultar
S29016-250	10"	273,05	4,19	127	1	Consultar
S29016-300	12"	323,85	4,57	152	1	Consultar

S29046 SCH 40 A-316L

INOX

TAPÓN
CAP

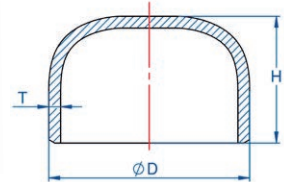

CÓDIGO	MEDIDA	D	T Sch 40	H		€
CODE	SIZE	D	T Sch 40	H		€
S29046-015	1/2"	21,34	2,77	25	1	Consultar
S29046-020	3/4"	26,67	2,87	25	1	Consultar
S29046-025	1"	33,4	3,38	38	1	Consultar
S29046-032	1 1/4"	42,16	3,56	38	1	Consultar
S29046-040	1 1/2"	48,26	3,68	38	1	Consultar
S29046-050	2"	60,33	3,91	38	1	Consultar
S29046-065	2 1/2"	73,03	5,16	38	1	Consultar
S29046-080	3"	88,9	5,49	51	1	Consultar
S29046-100	4"	114,3	6,02	64	1	Consultar
S29046-125	5"	141,3	6,55	76	1	Consultar
S29046-150	6"	168,28	7,11	89	1	Consultar
S29046-200	8"	219,08	8,18	102	1	Consultar
S29046-250	10"	273,05	9,27	127	1	Consultar

S29614 SCH 10 A-304L

INOX

STUB END TIPO A
STUB END A TYPE

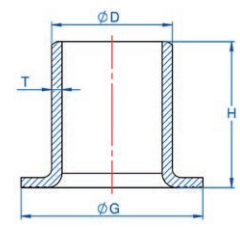
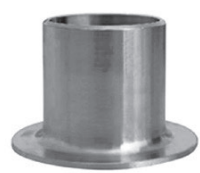

CÓDIGO	MEDIDA	D	G	H	T Sch 10		€
CODE	SIZE	D	G	H	T Sch 10		€
S29614-015	1/2"	21,34	35	51	2,11	1	Consultar
S29614-020	3/4"	26,67	43	51	2,11	1	Consultar
S29614-025	1"	33,4	50,8	51	2,77	1	Consultar
S29614-032	1 1/4"	42,16	63,5	51	2,77	1	Consultar
S29614-040	1 1/2"	48,26	73	51	2,77	1	Consultar
S29614-050	2"	60,33	92	63,5	2,77	1	Consultar
S29614-065	2 1/2"	73,03	105	63,5	3,05	1	Consultar
S29614-080	3"	88,9	127	63,5	3,05	1	Consultar
S29614-100	4"	114,3	157	76	3,05	1	Consultar

S29616 SCH 10 A-316L

INOX

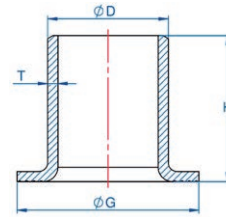
STUB END TIPO A
STUB END A TYPE

CÓDIGO	MEDIDA	D	G	H	T Sch 10		€
CODE	SIZE	D	G	H	T Sch 10		€
S29616-015	1/2"	21,34	35	51	2,11	1	Consultar
S29616-020	3/4"	26,67	43	51	2,11	1	Consultar
S29616-025	1"	33,4	50,8	51	2,77	1	Consultar
S29616-032	1 1/4"	42,16	63,5	51	2,77	1	Consultar
S29616-040	1 1/2"	48,26	73	51	2,77	1	Consultar
S29616-050	2"	60,33	92	63,5	2,77	1	Consultar
S29616-065	2 1/2"	73,03	105	63,5	3,05	1	Consultar
S29616-080	3"	88,9	127	63,5	3,05	1	Consultar
S29616-100	4"	114,3	157	76	3,05	1	Consultar

S29646 SCH 40 A-316L

INOX

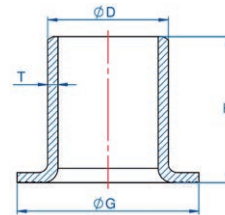
STUB END TIPO A
STUB END A TYPE

CÓDIGO	MEDIDA	D	G	H	T Sch 40		€
CODE	SIZE	D	G	H	T Sch 40		€
S29646-015	1/2"	21,34	35	51	2,77	1	Consultar
S29646-020	3/4"	26,67	43	51	2,87	1	Consultar
S29646-025	1"	33,4	50,8	51	3,38	1	Consultar
S29646-032	1 1/4"	42,16	63,5	51	3,56	1	Consultar
S29646-040	1 1/2"	48,26	73	51	3,68	1	Consultar
S29646-050	2"	60,33	92	63,5	3,91	1	Consultar
S29646-065	2 1/2"	73,03	105	63,5	5,16	1	Consultar
S29646-080	3"	88,9	127	63,5	5,49	1	Consultar
S29646-100	4"	114,3	157	76	6,02	1	Consultar

S24014 SCH 10 A-304L

REDUCCIÓN CONCÉNTRICA
CONCENTRIC REDUCER

INOX

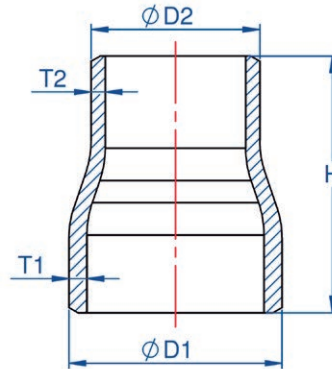

Sch 10

CÓDIGO	MEDIDA	D1	D2	H	T1	T2		€
CODE	SIZE	D1	D2	H	T1	T2		€
S24014-020015	3/4" x 1/2"	26,67	21,34	38	2,11	2,11	1	Consultar
S24014-025015	1" x 1/2"	33,4	21,34	51	2,77	2,11	1	Consultar
S24014-025020	1" x 3/4"	33,4	26,67	51	2,77	2,11	1	Consultar
S24014-032020	1 1/4" x 3/4"	42,16	26,67	51	2,77	2,11	1	Consultar
S24014-032025	1 1/4" x 1"	42,16	33,4	51	2,77	2,77	1	Consultar
S24014-040020	1 1/2" x 3/4"	48,26	26,67	64	2,77	2,11	1	Consultar
S24014-040025	1 1/2" x 1"	48,26	33,4	64	2,77	2,77	1	Consultar
S24014-040032	1 1/2" x 1 1/4"	48,26	42,16	64	2,77	2,77	1	Consultar
S24014-050020	2" x 3/4"	60,32	26,67	76	2,77	2,11	1	Consultar
S24014-050025	2" x 1"	60,32	33,4	76	2,77	2,77	1	Consultar
S24014-050032	2" x 1 1/4"	60,32	42,16	76	2,77	2,77	1	Consultar
S24014-050040	2" x 1 1/2"	60,32	48,26	76	2,77	2,77	1	Consultar
S24014-065025	2 1/2" x 1"	73,02	33,4	89	3,05	2,77	1	Consultar
S24014-065032	2 1/2" x 1 1/4"	73,02	42,16	89	3,05	2,77	1	Consultar
S24014-065040	2 1/2" x 1 1/2"	73,02	48,26	89	3,05	2,77	1	Consultar
S24014-065050	2 1/2" x 2"	73,02	60,32	89	3,05	2,77	1	Consultar
S24014-080040	3" x 1 1/2"	88,9	48,26	89	3,05	2,77	1	Consultar
S24014-080050	3" x 2"	88,9	60,32	89	3,05	2,77	1	Consultar
S24014-080065	3" x 2 1/2"	88,9	73,02	89	3,05	3,05	1	Consultar
S24014-100050	4" x 2"	114,3	60,32	102	3,05	2,77	1	Consultar
S24014-100065	4" x 2 1/2"	114,3	73,02	102	3,05	3,05	1	Consultar
S24014-100080	4" x 3"	114,3	88,9	102	3,05	3,05	1	Consultar
S24014-125080	5" x 3"	141,3	88,9	127	3,4	3,05	1	Consultar
S24014-125100	5" x 4"	141,3	114,3	127	3,4	3,05	1	Consultar
S24014-150100	6" x 4"	168,27	114,3	140	3,4	3,05	1	Consultar
S24014-150125	6" x 5"	168,27	141,3	140	3,4	3,4	1	Consultar
S24014-200100	8" x 4"	219,08	114,3	152	3,76	3,05	1	Consultar
S24014-200125	8" x 5"	219,08	141,3	152	3,76	3,4	1	Consultar
S24014-200150	8" x 6"	219,08	168,27	152	3,76	3,4	1	Consultar
S24014-250200	10" x 8"	273,05	219,08	178	4,19	3,76	1	Consultar
S24014-300250	12" x 10"	323,85	273,05	203	4,57	4,19	1	Consultar

S24016 SCH 10 A-316L

INOX

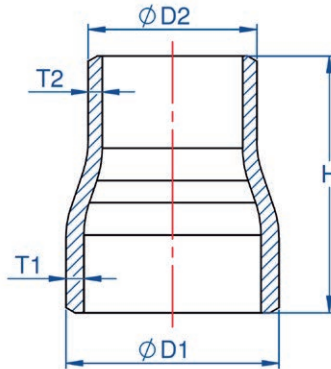
REDUCCIÓN CONCÉNTRICA
CONCENTRIC REDUCER

Sch 10

CÓDIGO	MEDIDA	D1	D2	H	T1	T2		€
CODE	SIZE	D1	D2	H	T1	T2		€
S24016-020015	3/4" x 1/2"	26,67	21,34	38	2,11	2,11	1	Consultar
S24016-025015	1" x 1/2"	33,4	21,34	51	2,77	2,11	1	Consultar
S24016-025020	1" x 3/4"	33,4	26,67	51	2,77	2,11	1	Consultar
S24016-032020	1 1/4" x 3/4"	42,16	26,67	51	2,77	2,11	1	Consultar
S24016-032025	1 1/4" x 1"	42,16	33,4	51	2,77	2,77	1	Consultar
S24016-040020	1 1/2" x 3/4"	48,26	26,67	64	2,77	2,11	1	Consultar
S24016-040025	1 1/2" x 1"	48,26	33,4	64	2,77	2,77	1	Consultar
S24016-040032	1 1/2" x 1 1/4"	48,26	42,16	64	2,77	2,77	1	Consultar
S24016-050020	2" x 3/4"	60,32	26,67	76	2,77	2,11	1	Consultar
S24016-050025	2" x 1"	60,32	33,4	76	2,77	2,77	1	Consultar
S24016-050032	2" x 1 1/4"	60,32	42,16	76	2,77	2,77	1	Consultar
S24016-050040	2" x 1 1/2"	60,32	48,26	76	2,77	2,77	1	Consultar
S24016-065025	2 1/2" x 1"	73,02	33,4	89	3,05	2,77	1	Consultar
S24016-065032	2 1/2" x 1 1/4"	73,02	42,16	89	3,05	2,77	1	Consultar
S24016-065040	2 1/2" x 1 1/2"	73,02	48,26	89	3,05	2,77	1	Consultar
S24016-065050	2 1/2" x 2"	73,02	60,32	89	3,05	2,77	1	Consultar
S24016-080040	3" x 1 1/2"	88,9	48,26	89	3,05	2,77	1	Consultar
S24016-080050	3" x 2"	88,9	60,32	89	3,05	2,77	1	Consultar
S24016-080065	3" x 2 1/2"	88,9	73,02	89	3,05	3,05	1	Consultar
S24016-100050	4" x 2"	114,3	60,32	102	3,05	2,77	1	Consultar
S24016-100065	4" x 2 1/2"	114,3	73,02	102	3,05	3,05	1	Consultar
S24016-100080	4" x 3"	114,3	88,9	102	3,05	3,05	1	Consultar
S24016-125080	5" x 3"	141,3	88,9	127	3,4	3,05	1	Consultar
S24016-125100	5" x 4"	141,3	114,3	127	3,4	3,05	1	Consultar
S24016-150100	6" x 4"	168,27	114,3	140	3,4	3,05	1	Consultar
S24016-150125	6" x 5"	168,27	141,3	140	3,4	3,4	1	Consultar
S24016-200100	8" x 4"	219,08	114,3	152	3,76	3,05	1	Consultar
S24016-200125	8" x 5"	219,08	141,3	152	3,76	3,4	1	Consultar
S24016-200150	8" x 6"	219,08	168,27	152	3,76	3,4	1	Consultar
S24016-250200	10" x 8"	273,05	219,08	178	4,19	3,76	1	Consultar
S24016-300250	12" x 10"	323,85	273,05	203	4,57	4,19	1	Consultar

S24046 SCH 40 A-316L

REDUCCIÓN CONCÉNTRICA
CONCENTRIC REDUCER

INOX

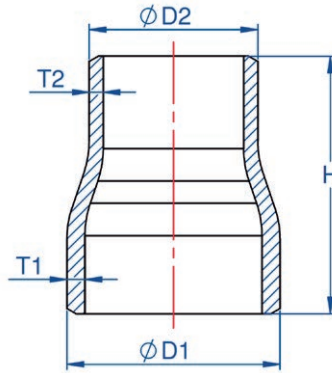

Sch 40

CÓDIGO	MEDIDA	D1	D2	H	T1	T2		€
CODE	SIZE	D1	D2	H	T1	T2		€
S24046-020015	3/4" x 1/2"	26,67	21,34	38	2,87	2,77	1	Consultar
S24046-025015	1" x 1/2"	33,4	21,34	51	3,38	2,77	1	Consultar
S24046-025020	1" x 3/4"	33,4	26,67	51	3,38	2,87	1	Consultar
S24046-032020	1 1/4" x 3/4"	42,16	26,67	51	3,56	2,87	1	Consultar
S24046-032025	1 1/4" x 1"	42,16	33,4	51	3,56	3,38	1	Consultar
S24046-040020	1 1/2" x 3/4"	48,26	26,67	64	3,68	2,87	1	Consultar
S24046-040025	1 1/2" x 1"	48,26	33,4	64	3,68	3,38	1	Consultar
S24046-040032	1 1/2" x 1 1/4"	48,26	42,16	64	3,68	3,56	1	Consultar
S24046-050020	2" x 3/4"	60,32	26,67	76	3,91	2,87	1	Consultar
S24046-050025	2" x 1"	60,32	33,4	76	3,91	3,38	1	Consultar
S24046-050032	2" x 1 1/4"	60,32	42,16	76	3,91	3,56	1	Consultar
S24046-050040	2" x 1 1/2"	60,32	48,26	76	3,91	3,68	1	Consultar
S24046-065025	2 1/2" x 1"	73,02	33,4	89	5,16	3,38	1	Consultar
S24046-065032	2 1/2" x 1 1/4"	73,02	42,16	89	5,16	3,56	1	Consultar
S24046-065040	2 1/2" x 1 1/2"	73,02	48,26	89	5,16	3,68	1	Consultar
S24046-065050	2 1/2" x 2"	73,02	60,32	89	5,16	3,91	1	Consultar
S24046-080040	3" x 1 1/2"	88,9	48,26	89	5,49	3,68	1	Consultar
S24046-080050	3" x 2"	88,9	60,32	89	5,49	3,91	1	Consultar
S24046-080065	3" x 2 1/2"	88,9	73,02	89	5,49	5,16	1	Consultar
S24046-100050	4" x 2"	114,3	60,32	102	6,02	3,91	1	Consultar
S24046-100065	4" x 2 1/2"	114,3	73,02	102	6,02	5,16	1	Consultar
S24046-100080	4" x 3"	114,3	88,9	102	6,02	5,49	1	Consultar
S24046-125080	5" x 3"	141,3	88,9	127	6,55	5,49	1	Consultar
S24046-125100	5" x 4"	141,3	114,3	127	6,55	6,02	1	Consultar
S24046-150100	6" x 4"	168,27	114,3	140	7,11	6,02	1	Consultar
S24046-150125	6" x 5"	168,27	141,3	140	7,11	6,55	1	Consultar
S24046-200100	8" x 4"	219,08	114,3	152	8,18	6,02	1	Consultar
S24046-200125	8" x 5"	219,08	141,3	152	8,18	6,55	1	Consultar
S24046-200150	8" x 6"	219,08	168,27	152	8,18	7,11	1	Consultar
S24046-250200	10" x 8"	273,05	219,08	178	9,27	8,18	1	Consultar

LEYENDA DE ICONOS**ICON KEY**

Posibles codificaciones aplicadas en esta sección.

Possible encodings applied in this section.



CERTIFICADOS DE PRODUCTO
PRODUCT CERTIFICATES

INOX**R**

Inoxidable
Stainless steel

Recambios
Spare parts

PROPIEDADES DE PRODUCTO
PRODUCT PROPERTIES

**APLICACIONES**

Junta EPDM: agua sanitaria, calefacción, contra incendios y aire comprimido (libre de aceite).
Junta FKM: aceites, hidrocarburos (excepto gasoil), instalaciones solares, aire comprimido.

APLICATIONS

EPDM O-ring: hot water, heating, fire protection and compressed air (oil-free).
FKM O-ring: oils, hydrocarbons (except diesel), solar power installations, compressed air.

Diámetro (mm)	Espesor mm
Diameter (mm)	Thickness mm
15	0,60 1,00
18	0,70 1,00
22	0,70 1,20
28	0,80 1,20
35	1,00 1,50
42	1,20 1,50
54	1,20 1,50
76,1	1,50 2,00
88,9	2,00
108	2,00

MT[®]
INDUSTRIAL



ACC. INOX. MT PRESS
MT PRESS S.S. FITTINGS

01040

CURVA 45° M-H
F-M 45° ELBOW

DVGW

INOX

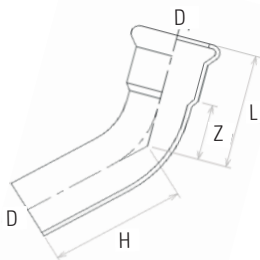

CÓDIGO	MEDIDA	L	H	Z			€
CODE	SIZE	L	H	Z			€
01040-015	15	35	40	15	160	10	4,06
01040-018	18	37	42	17	140	10	4,61
01040-022	22	42	52	21	90	10	5,55
01040-028	28	48	56	25	50	10	6,91
01040-035	35	54	69	28	50	5	9,87
01040-042	42	67	72	37	30	5	15,00
01040-054	54	81	96	46	20	5	18,68
01040-076	76	119	115	66	8	1	69,90
01040-088	88	143	130	83	4	1	85,63
01040-108	108	162	172	87	2	1	117,26

01041

CURVA 45° H-H
F-F 45° ELBOW

DVGW

INOX

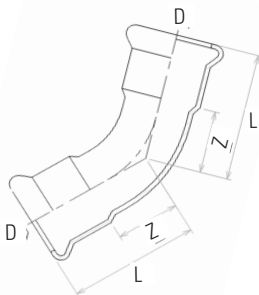

CÓDIGO	MEDIDA	L	Z			€
CODE	SIZE	L	Z			€
01041-015	15	35	15	160	10	5,25
01041-018	18	37	17	140	10	5,78
01041-022	22	42	21	100	10	6,87
01041-028	28	48	25	50	10	8,43
01041-035	35	54	28	60	5	11,88
01041-042	42	67	37	40	5	15,28
01041-054	54	81	46	20	5	20,82
01041-076	76	112	59	8	1	78,55
01041-088	88	127	67	4	1	94,84
01041-108	108	155	80	2	1	128,82

01001

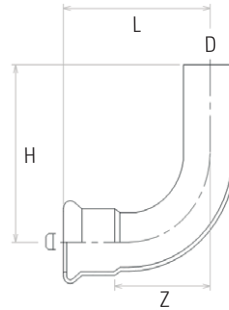
CURVA 90° M-H
M-F 90° ELBOW

DVGW

INOX

CÓDIGO	MEDIDA	L	H	Z			€
CODE	SIZE	L	H	Z			€
01001-015	15	49	57	29	140	10	4,29
01001-018	18	53	61	33	110	10	5,02
01001-022	22	61	70	40	70	10	6,15
01001-028	28	72	79	49	40	10	8,03
01001-035	35	86	91	60	50	5	11,91
01001-042	42	112	127	82	30	5	16,90
01001-054	54	138	153	103	15	5	24,01
01001-076	76	175	188	122	4	1	94,94
01001-088	88	208	223	148	3	1	119,13
01001-108	108	243	262	168	1	1	163,29

01002

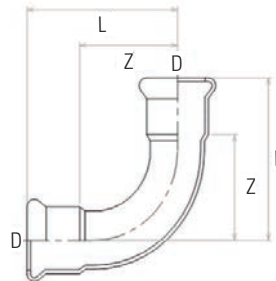
CURVA 90° H-H
F-F 90° ELBOW

DVGW

INOX

CÓDIGO	MEDIDA	L	Z			€
CODE	SIZE	L	Z			€
01002-015	15	49	29	140	10	4,73
01002-018	18	53	33	100	10	5,45
01002-022	22	61	40	80	10	6,66
01002-028	28	72	49	40	10	8,58
01002-035	35	86	60	50	5	12,93
01002-042	42	112	82	30	5	17,97
01002-054	54	138	103	15	5	25,25
01002-076	76	184	131	4	1	103,19
01002-088	88	210	150	3	1	128,35
01002-108	108	241	166	1	1	174,84

01003

CURVA 90° M
M 90° ELBOW

DVGW

INOX

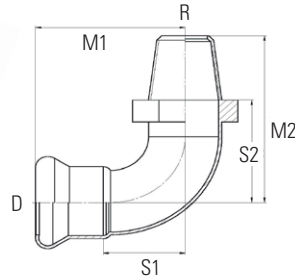

CÓDIGO	MEDIDA	R	D	S1	S2	M1	M2			€
CODE	SIZE	R	D	S1	S2	M1	M2			€
01003-03525	35 x 1"	1"	35	61	63	87	89	15	1	27,47
01003-03532	35 x 1 1/4"	1 1/4"	35	61	63	87	89	10	1	28,63
01003-04232	42 x 1 1/4"	1 1/4"	42	83	85	113	115	6	1	33,33

01090

CODO 90° H
F 90° ELBOW

DVGW

INOX

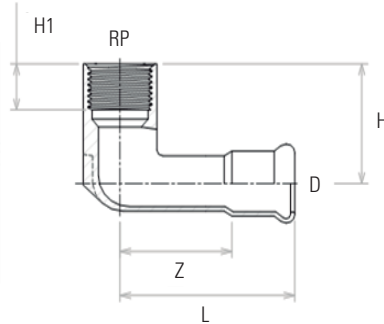

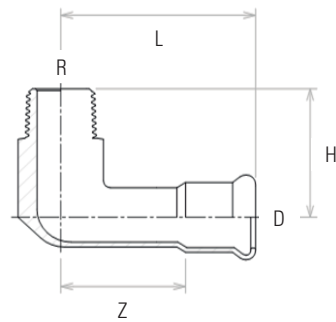

CÓDIGO	MEDIDA	RP	H	H1	L	Z			€
CODE	SIZE	RP	H	H1	L	Z			€
01090-01515	15 x 1/2"	1/2"	37	12	55	35	100	10	8,52
01090-01520	15 x 3/4"	3/4"	37	14	58	37	100	10	10,82
01090-01815	18 x 1/2"	1/2"	39	12	57	37	100	10	10,92
01090-01820	18 x 3/4"	3/4"	39	14	60	37	100	10	12,98
01090-02220	22 x 3/4"	3/4"	46	14	60	39	50	10	13,21
01090-02825	28 x 1"	1	54	19	67	44	30	10	17,57
01090-03532	35 x 1 1/4"	1 1/4"	63	22	75	49	35	5	28,92

01092

CODO 90° M
M 90° ELBOW

DVGW

INOX

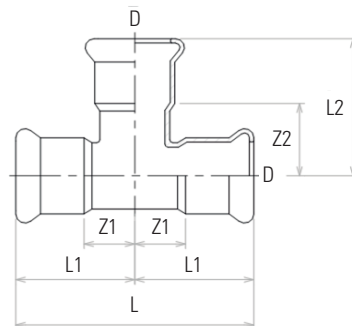

CÓDIGO	MEDIDA	R	L	H	Z			€
CODE	SIZE	R	L	H	Z			€
01092-01515	15 x 1/2"	1/2"	55	37	35	100	10	8,32
01092-01815	18 x 1/2"	1/2"	57	39	37	100	10	8,78
01092-01820	18 x 3/4"	3/4"	57	42	37	100	10	12,29
01092-02220	22 x 3/4"	3/4"	60	46	39	60	10	12,62
01092-02825	28 x 1"	1"	67	54	44	40	10	16,51
01092-03532	35 x 1 1/4"	1 1/4"	75	63	49	35	5	28,98
01092-04240	42 x 1 1/2"	1 1/2"	83	67	53	30	5	40,57
01092-05450	54 x 2"	2"	94	78	59	20	5	52,67

01130

TE IGUAL
EQUAL TEE

DVGW

INOX

CÓDIGO	MEDIDA	L	L1	L2	Z1	Z2			€
CODE	SIZE	L	L1	L2	Z1	Z2			€
01130-015	15	66	33	39	13	15	100	10	7,70
01130-018	18	68	34	41	14	16	80	10	8,64
01130-022	22	74	37	44	16	18	60	10	9,98
01130-028	28	84	42	53	19	22	30	10	12,44
01130-035	35	100	53	57	27	30	30	5	16,61
01130-042	42	114	57	62	27	30	20	5	20,75
01130-054	54	138	69	77	34	37	15	5	27,55
01130-076	76	230	115	110	62	66	4	1	98,64
01130-088	88	260	130	128	70	76	2	1	124,56
01130-108	108	310	150	153	75	82	1	1	174,21

01131

TE HEMBRA ROSCADA
BRANCH TEE FEMALE OUTLET

DVGW **INOX**

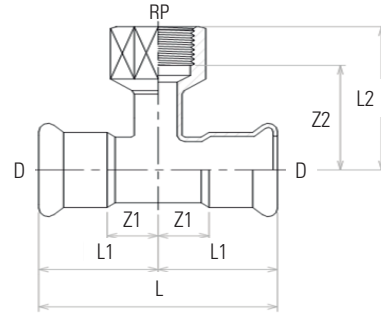

CÓDIGO	MEDIDA	Rp	L	L1	L2	Z1	Z2			€
CODE	SIZE	Rp	L	L1	L2	Z1	Z2			€
01131-01515	15 x 1/2" x 15	1/2"	66	33	38	13	24	100	10	8,84
01131-01815	18 x 1/2" x 18	1/2"	68	34	41	14	27	80	10	9,57
01131-01820	18 x 3/4" x 18	3/4"	68	34	43	14	28	70	10	11,23
01131-02215	22 x 1/2" x 22	1/2"	74	37	42	16	28	60	10	11,44
01131-02220	22 x 3/4" x 22	3/4"	74	37	45	16	30	60	10	12,52
01131-02815	28 x 1/2" x 28	1/2"	84	42	45	19	31	40	10	13,22
01131-02820	28 x 3/4" x 28	3/4"	84	42	47	19	32	30	10	15,23
01131-02825	28 x 1" x 28	1"	84	42	52	19	36	30	10	16,78
01131-03515	35 x 1/2" x 35	1/2"	100	50	49	24	34	40	5	16,28
01131-03520	35 x 3/4" x 35	3/4"	100	50	51	24	36	40	5	17,40
01131-03525	35 x 1" x 35	1"	100	50	56	24	40	40	5	21,77
01131-03532	35 x 1 1/4" x 35	1 1/4"	100	50	57	24	37	40	5	23,80
01131-04215	42 x 1/2" x 42	1/2"	114	57	53	27	39	30	5	19,21
01131-04220	42 x 3/4" x 42	3/4"	114	57	54	27	39	30	5	20,54
01131-04225	42 x 1" x 42	1"	114	57	59	27	43	30	5	24,69
01131-04240	42 x 1 1/2" x 42	1 1/2"	114	57	60	27	40	30	5	29,56
01131-05415	54 x 1/2" x 54	1/2"	138	69	58	34	44	15	5	24,37
01131-05420	54 x 3/4" x 54	3/4"	138	69	60	34	45	15	5	25,35
01131-05425	54 x 1" x 54	1"	138	69	65	34	49	15	5	29,82
01131-05450	54 x 2" x 54	2"	138	69	78	34	54	15	5	45,67
01131-07620	76 x 3/4" x 76	3/4"	230	115	70	62	55	6	1	80,25
01131-07650	76 x 2" x 76	2"	230	115	88	62	64	4	1	86,06
01131-08820	88 x 3/4" x 88	3/4"	260	130	78	70	62	2	1	89,72
01131-08850	88 x 2" x 88	2"	260	130	96	70	71	2	1	102,17
01131-10820	108 x 3/4" x 108	3/4"	310	155	86	80	71	2	1	145,32
01131-10850	108 x 2" x 108	2"	310	155	104	80	79	2	1	156,52

01132

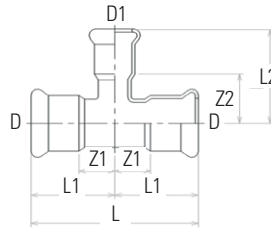
TE REDUCIDA
REDUCING TEE

DVGW

INOX

CÓDIGO	MEDIDA	L	L1	L2	Z1	Z2			€
CODE	SIZE	L	L1	L2	Z1	Z2			€
01132-01815	18 x 15 x 18	68	34	41	14	20	80	10	8,52
01132-02215	22 x 15 x 22	74	37	43	16	22	70	10	9,60
01132-02218	22 x 18 x 22	74	37	43	16	22	60	10	9,84
01132-02228	22 x 28 x 22	74	37	49	16	24	60	10	12,29
01132-02815	28 x 15 x 28	84	42	46	19	25	40	10	11,39
01132-02818	28 x 18 x 28	84	42	46	19	25	40	10	11,62
01132-02822	28 x 22 x 28	84	42	47	19	26	40	10	11,88
01132-03515	35 x 15 x 35	100	50	49	24	29	40	5	14,47
01132-03518	35 x 18 x 35	100	50	49	24	29	40	5	14,70
01132-03522	35 x 22 x 35	100	50	50	24	30	40	5	14,95
01132-03528	35 x 28 x 35	100	50	53	24	33	40	5	15,65
01132-04215	42 x 15 x 42	114	57	51	27	33	30	5	17,40
01132-04218	42 x 18 x 42	114	57	53	27	33	30	5	17,63
01132-04222	42 x 22 x 42	114	57	54	27	34	30	5	17,89
01132-04228	42 x 28 x 42	114	57	57	27	37	30	5	18,56
01132-04235	42 x 35 x 42	114	57	61	27	34	25	5	19,78
01132-05415	54 x 15 x 54	138	69	57	34	39	15	5	22,53
01132-05418	54 x 18 x 54	138	69	59	34	39	15	5	22,76
01132-05422	54 x 22 x 54	138	69	60	34	40	15	5	23,05
01132-05428	54 x 28 x 54	138	69	63	34	43	15	5	23,73
01132-05435	54 x 35 x 54	138	69	67	34	40	15	5	24,96
01132-05442	54 x 42 x 54	138	69	71	34	38	15	5	26,12
01132-07622	76 x 22 x 76	230	115	70	62	50	8	1	73,65
01132-07628	76 x 28 x 76	230	115	75	62	53	6	1	74,85
01132-07635	76 x 35 x 76	230	115	77	62	50	6	1	78,15
01132-07642	76 x 42 x 76	230	115	82	62	48	6	1	78,57
01132-07654	76 x 54 x 76	230	115	88	62	53	6	1	80,53
01132-08822	88 x 22 x 88	260	130	76	70	58	2	1	84,42
01132-08828	88 x 28 x 88	260	130	81	70	61	2	1	87,19
01132-08835	88 x 35 x 88	260	130	83	70	58	2	1	89,62
01132-08842	88 x 42 x 88	260	130	87	70	58	2	1	92,88
01132-08854	88 x 54 x 88	260	130	93	70	63	2	1	95,31
01132-08876	88 x 76 x 88	260	130	118	70	69	2	1	101,83
01132-10822	108 x 22 x 108	310	152	86	77	73	2	1	109,79
01132-10828	108 x 28 x 108	310	155	93	80	76	2	1	110,46
01132-10835	108 x 35 x 108	310	155	93	80	69	2	1	113,34
01132-10842	108 x 42 x 108	310	155	97	80	67	2	1	115,22
01132-10854	108 x 54 x 108	310	155	105	80	71	2	1	120,29
01132-10876	108 x 76 x 108	310	155	131	80	77	2	1	136,77
01132-10888	108 x 88 x 108	310	155	141	80	80	1	1	138,90

01246

DVGW INOX

REDUCCIÓN M-H
M-F REDUCING

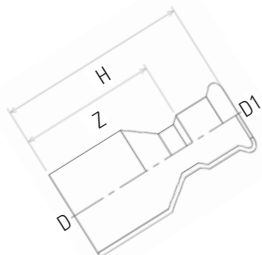

CÓDIGO	MEDIDA	H	Z			€
CODE	SIZE	H	Z			€
01246-01815	18 x 15	60	40	160	10	4,43
01246-02215	22 x 15	63	43	150	10	5,14
01246-02218	22 x 18	62	42	130	10	4,88
01246-02815	28 x 15	66	46	120	10	6,13
01246-02818	28 x 18	64	44	120	10	5,87
01246-02822	28 x 22	62	41	100	10	5,52
01246-03515	35 x 15	77	55	150	5	11,42
01246-03518	35 x 18	77	57	150	5	8,72
01246-03522	35 x 22	71	50	150	5	7,67
01246-03528	35 x 28	78	55	120	5	7,41
01246-04215	42 x 15	80	55	100	5	10,79
01246-04218	42 x 18	82	62	80	5	11,13
01246-04222	42 x 22	94	73	80	5	9,95
01246-04228	42 x 28	83	60	80	5	9,75
01246-04235	42 x 35	77	51	80	5	9,19
01246-05415	54 x 15	85	55	50	5	18,50
01246-05418	54 x 18	94	74	50	5	17,51
01246-05422	54 x 22	95	74	50	5	14,27
01246-05428	54 x 28	100	77	50	5	13,71
01246-05435	54 x 35	99	73	50	5	12,98
01246-05442	54 x 42	92	62	40	5	12,02
01246-07642	76 x 42	-	-	24	1	36,23
01246-07654	76 x 54	146	111	24	1	34,27
01246-08854	88 x 54	163	128	12	1	38,79
01246-08876	88 x 76	161	108	8	1	46,11
01246-10854	108 x 54	163	128	7	1	49,96
01246-10876	108 x 76	184	131	7	1	62,04
01246-10888	108 x 88	203	143	4	1	76,81

01270

DVGW INOX

MANGUITO H-H
F-F COUPLING

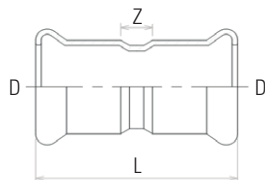

CÓDIGO	MEDIDA	L	Z			€
CODE	SIZE	L	Z			€
01270-015	15	48	8	160	10	3,56
01270-018	18	48	8	140	10	3,83
01270-022	22	50	8	120	10	4,09
01270-028	28	54	8	80	10	4,88
01270-035	35	62	10	100	5	7,18
01270-042	42	71	11	60	5	9,08
01270-054	54	83	13	30	5	11,73
01270-076	76	141	35	8	1	38,06
01270-088	88	162	42	7	1	47,89
01270-108	108	194	44	3	1	67,65

01290

DVGW

INOX

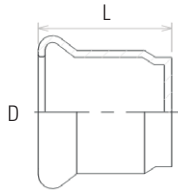
TAPÓN
CAP

01340

DVGW

INOX

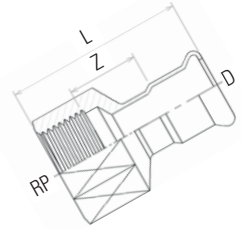
UNIÓN H
F UNION

CÓDIGO CODE	MEDIDA SIZE	L			€
01290-015	15	28	200	10	4,86
01290-018	18	30	180	10	5,58
01290-022	22	31	150	10	6,07
01290-028	28	32	100	10	7,24
01290-035	35	34	120	5	8,42
01290-042	42	39	70	5	12,04
01290-054	54	45	50	5	13,26
01290-076	76	67	20	1	34,27
01290-088	88	78	16	1	40,77
01290-108	108	94	6	1	55,83

CÓDIGO CODE	MEDIDA SIZE (DxRp)	L	Z			€
01340-01510	15 x 3/8"	53	33	160	10	8,04
01340-01515	15 x 1/2"	55	35	160	10	6,27
01340-01520	15 x 3/4"	57	37	140	10	8,40
01340-01815	18 x 1/2"	59	39	120	10	7,21
01340-01820	18 x 3/4"	62	42	120	10	7,73
01340-02215	22 x 1/2"	60	39	100	10	8,12
01340-02220	22 x 3/4"	62	41	100	10	8,30
01340-02225	22 x 1"	66	45	100	10	10,39
01340-02820	28 x 3/4"	65	42	60	10	11,44
01340-02825	28 x 1"	70	47	60	10	11,84
01340-02832	28 x 1 1/4"	70	47	60	10	14,97
01340-03525	35 x 1"	65	39	80	5	14,89
01340-03532	35 x 1 1/4"	72	46	80	5	16,14
01340-03540	35 x 1 1/2"	72	46	60	5	17,84
01340-04232	42 x 1 1/4"	71	41	50	5	18,43
01340-04240	42 x 1 1/2"	77	47	40	5	19,49
01340-05440	54 x 1 1/2"	77	42	30	5	27,91
01340-05450	54 x 2"	95	60	30	5	32,88
01340-07665	76 x 2 1/2"	116	67	8	1	67,99
01340-08880*	88 x 3"	-	-	2	1	157,33

- Disponible hasta agotar existencias
While stocks lasts

01341

DVGW

INOX

UNIÓN M
M UNION

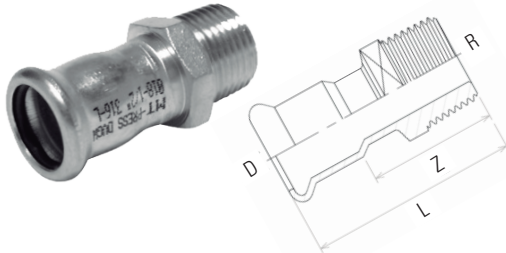

CÓDIGO	MEDIDA	L	Z			€
CODE	SIZE (DxRp)	L	Z			€
01341-01510	15 x 3/8"	53	33	160	10	7,63
01341-01515	15 x 1/2"	55	35	160	10	7,00
01341-01520	15 x 3/4"	57	37	160	10	8,06
01341-01815	18 x 1/2"	55	35	120	10	6,17
01341-01820	18 x 3/4"	59	39	120	10	7,70
01341-02215	22 x 1/2"	56	35	100	10	7,53
01341-02220	22 x 3/4"	60	39	100	10	8,26
01341-02225	22 x 1"	63	42	80	10	10,30
01341-02820	28 x 3/4"	66	43	60	10	9,91
01341-02825	28 x 1"	68	45	60	10	10,47
01341-02832	28 x 1 1/4"	70	47	50	10	14,50
01341-03525	35 x 1"	69	43	100	5	12,84
01341-03532	35 x 1 1/4"	70	44	100	5	14,70
01341-03540	35 x 1 1/2"	70	44	100	5	18,27
01341-04232	42 x 1 1/4"	76	46	50	5	15,68
01341-04240	42 x 1 1/2"	76	46	50	5	18,30
01341-05440	54 x 1 1/2"	84	49	30	5	23,02
01341-05450	54 x 2"	90	55	30	5	28,70
01341-07665	76 x 2 1/2"	115	62	8	1	67,62
01341-08880	88 x 3"	130	70	7	1	101,71
01341-08100	108 x 4"	157	82	3	1	157,08

01359

DVGW

INOX

RACOR DOS PIEZAS H
F TAP CONNECTOR TWO PIECES

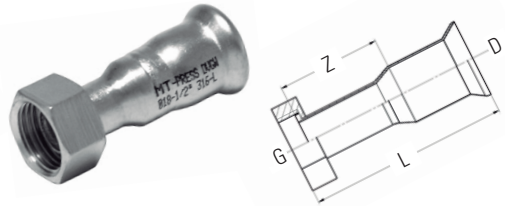

CÓDIGO	MEDIDA	L	Z			€
CODE	SIZE (DxG)	L	Z			€
01359-01515	15 x 1/2"	46	18	200	10	10,65
01359-01520	15 x 3/4"	47	18	180	10	10,69
01359-01815	18 x 1/2"	50	20	180	10	10,89
01359-01820	18 x 3/4"	52	20	160	10	12,16
01359-02220	22 x 3/4"	52	21	120	10	15,65
01359-02225	22 x 1"	54	21	120	10	15,65
01359-02825	28 x 1"	59	24	80	10	19,20
01359-02832	28 x 1 1/4"	61	26	80	10	19,20
01359-03532	35 x 1 1/4"	63	25	80	5	27,62
01359-03540	35 x 1 1/2"	64	25	80	5	30,01
01359-04240	42 x 1 1/2"	68	25	70	5	36,61
01359-04250	42 x 2"	68	25	60	5	39,83
01359-05450	54 x 2"	74	24	30	5	59,10
01359-05465	54 x 2 1/2"	75	24	30	5	44,81
01359-07665	76 x 2 1/2"	82	28	16	1	156,06

- Junta plana incluida
Flat joint included

01321

BRIDA ADAPTADOR
ADAPTOR FLANGE

DVGW

INOX

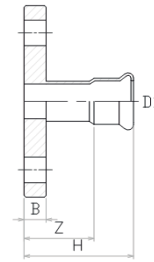
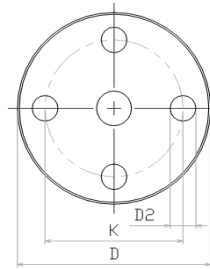

CÓDIGO	MEDIDA	D	K	B	H	Z	D2	N			€
CODE	SIZE	D	K	B	H	Z	D2	N			€
01321-015	15	95	65	11	47	27	14	4	20	1	37,01
01321-018	18	95	65	11	48	28	14	4	20	1	37,15
01321-022	22	105	75	12	52	31	14	4	12	1	47,08
01321-028	28	115	85	14	59	36	14	4	12	1	63,16
01321-035	35	140	100	15	68	42	18	4	10	1	84,34
01321-042	42	150	110	16	76	46	18	4	8	1	100,68
01321-054	54	165	125	18	90	55	18	4	6	1	129,28
01321-076	76	185	145	18	136	83	18	4	3	1	172,45
01321-088	88	200	160	20	152	92	18	8	3	1	210,33
01321-108	108	220	180	20	178	103	18	8	2	1	258,25

01360

RACOR TRES PIEZAS
TAP CONNECTOR THREE PIECES

DVGW

INOX

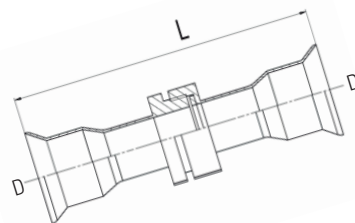

CÓDIGO	MEDIDA	L			€
CODE	SIZE (D)	L			€
01360-015	15	89	100	10	15,94
01360-018	18	92	80	10	18,92
01360-022	22	99	50	10	22,99
01360-028	28	112	30	10	32,52
01360-035	35	119	40	5	43,25
01360-042	42	128	30	5	54,24
01360-054	54	141	15	5	71,45

01440

DVGW

INOX

CONECTOR H
F CONNECTOR

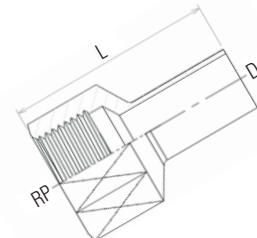

CÓDIGO	MEDIDA	L			€
CODE	SIZE (DxRp)	L			€
01440-01515	15 x 1/2"	54	180	10	6,12
01440-01815	18 x 1/2"	57	160	10	6,49
01440-01820	18 x 3/4"	57	140	10	7,62
01440-02215	22 x 1/2"	60	100	10	7,81
01440-02220	22 x 3/4"	60	100	10	9,26
01440-02820	28 x 3/4"	66	60	10	11,77
01440-02825	28 x 1"	69	60	10	12,25

01441

DVGW

INOX

CONECTOR M
M CONNECTOR

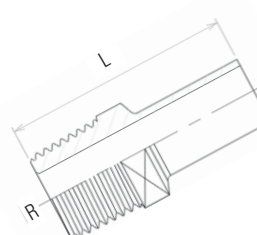

CÓDIGO	MEDIDA	L			€
CODE	SIZE (DxR)	L			€
01441-01515	15 x 1/2"	53	180	10	5,87
01441-01815	18 x 1/2"	57	160	10	6,18
01441-01820	18 x 3/4"	57	140	10	6,68
01441-02215	22 x 1/2"	59	100	10	7,82
01441-02220	22 x 3/4"	59	100	10	8,66
01441-02820	28 x 3/4"	63	60	10	11,77
01441-02825	28 x 1"	66	60	10	12,03



01472

CODO PLACA
WALL PLATED ELBOW

DVGW

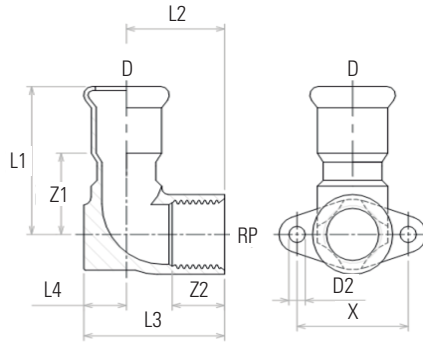
INOX



CÓDIGO	MEDIDA	L1	L2	L3	L4	Z1	Z2	D2	X			€
CODE	SIZE (DxRp)	L1	L2	L3	L4	Z1	Z2	D2	X			€
01472-01515	15 x 1/2"	50	30	65	35	30	15	4,8	34	100	10	9,34
01472-01815	18 x 1/2"	50	30	65	35	30	15	5	34	90	10	9,63
01472-02220	22 x 3/4"	54	34	65	31	33	16	6	40	60	10	12,22

JE



DVGW

INOX

R

RECAMBIO - JUNTA EPDM
SPARE PART - O-RING EPDM



CÓDIGO CODE	MEDIDA SIZE			€ €
JE015	15	5000	500	0,15
JE018	18	5000	500	0,17
JE022	22	3000	300	0,28
JE028	28	3000	300	0,40
JE035	35	3000	300	0,46
JE042	42	2000	200	0,72
JE054	54	2000	200	0,93
JE076	76	150	15	2,80
JE088	88	150	15	3,29
JE108	108	150	15	5,30

JV



DVGW

INOX

R

RECAMBIO - JUNTA FKM
SPARE PART - O-RING FKM



CÓDIGO CODE	MEDIDA SIZE			€ €
JV015	15	5000	500	0,72
JV018	18	5000	500	0,80
JV022	22	3000	300	1,12
JV028	28	3000	300	1,33
JV035	35	3000	300	1,65
JV042	42	2000	200	2,95
JV054	54	2000	200	3,67
JV076	76	150	15	12,71
JV088	88	150	15	19,48
JV108	108	150	15	36,98

015004

DVGW

INOX

AISI 304L

TUBO SOLDADO EN ACERO INOXIDABLE 304L
WELDED STAINLESS STEEL PIPE 304L

CÓDIGO	MEDIDA	METROS	€
CODE	SIZE	METERS	€
015004-01506	15 x 0.6	5	Consultar
015004-01510	15 x 1.0	6	Consultar
015004-01807	18 x 0.7	5	Consultar
015004-01810	18 x 1.0	6	Consultar
015004-02207	22 x 0.7	5	Consultar
015004-02212	22 x 1.2	6	Consultar
015004-02808	28 x 0.8	5	Consultar
015004-02812	28 x 1.2	6	Consultar
015004-03510	35 x 1.0	5	Consultar
015004-03515	35 x 1.5	6	Consultar
015004-04212	42 x 1.2	5	Consultar
015004-04215	42 x 1.5	6	Consultar
015004-05412	54 x 1.2	5	Consultar
015004-05415	54 x 1.5	6	Consultar
015004-07615	76.1 x 1.5	6	Consultar
015004-07620	76.1 x 2.0	6	Consultar
015004-08820	88.9 x 2.0	6	Consultar
015004-10820	108 x 2.0	6	Consultar

- Para otras dimensiones y cantidades consultar
For other dimensions or quantity pipes under consult

DIÁMETRO EXTERIOR	GROSOR	PESO POR METRO (KG)
EXTERNAL DIAMETER	THICKNESS	WEIGHT PER METER (KG)
15	0,6	0,22
18	0,7	0,30
22	0,7	0,37
28	0,8	0,55
35	1,0	0,85
42	1,2	1,23
54	1,2	1,59
76,1	1,5	2,81
88,9	2,0	4,36
108	2,0	5,31

- Tubería de acero inoxidable según las norma DVGW GW 541 y UNE-EN-10088
Stainless steel pipe according to DVGW GW 541 and UNE-EN-10088

015006

DVGW

INOX

AISI 316L

TUBO SOLDADO EN ACERO INOXIDABLE 316L
WELDED STAINLESS STEEL PIPE 316L

CÓDIGO	MEDIDA	METROS	€
CODE	SIZE	METERS	€
015006-01506	15 x 0.6	5	Consultar
015006-01510	15 x 1.0	6	Consultar
015006-01807	18 x 0.7	5	Consultar
015006-01810	18 x 1.0	6	Consultar
015006-02207	22 x 0.7	5	Consultar
015006-02212	22 x 1.2	6	Consultar
015006-02808	28 x 0.8	5	Consultar
015006-02812	28 x 1.2	6	Consultar
015006-03510	35 x 1.0	5	Consultar
015006-03515	35 x 1.5	6	Consultar
015006-04212	42 x 1.2	5	Consultar
015006-04215	42 x 1.5	6	Consultar
015006-05412	54 x 1.2	5	Consultar
015006-05415	54 x 1.5	6	Consultar
015006-07615	76 x 1.5	6	Consultar
015006-07620	76.1 x 2.0	6	Consultar
015006-08820	88.9 x 2.0	6	Consultar
015006-10820	108 x 2.0	6	Consultar

- Para otras dimensiones y cantidades consultar
For other dimensions or quantity pipes under consult

DIÁMETRO EXTERIOR	GROSOR	PESO POR METRO (KG)
EXTERNAL DIAMETER	THICKNESS	WEIGHT PER METER (KG)
15	1,0	0,35
18	1,0	0,43
22	1,2	0,63
28	1,2	0,81
35	1,5	1,26
42	1,5	1,52
54	1,5	1,97
76,1	2,0	3,72
88,9	2,0	4,36
108	2,0	5,31

COMPATIBILIDAD DIÁMETRO / MATERIALES
DIAMETER / MATERIAL COMPATIBILITY

FLUIDOS FLUIDS	EPDM	FKM
ACEITES SINTÉTICOS SINTETIC OIL	X	✓
ACEITES VEGETALES VEGETABLE OIL	✓	✓
ÁCIDO ACÉTICO ACETIC ACID	✓	X
ÁCIDO CLORHÍDRICO HYDROCHLORIC ACID	✓	✓
ÁCIDO FÓRMICO FORMIC ACID	✓	X
ÁCIDO NÍTRICO NITRIC ACID	X	✓
ÁCIDO SULFÚRICO SULFURIC ACID	X	✓
AMONÍACO AMMONIA	✓	X
AGUA DESTILADA DISTILLED WATER	✓	✓
AGUA LÍQUIDA <100° LIQUID WATER	✓	✓
AGUA VAPOR <140° STEAM	✓	✓
AGUA VAPOR >140° STEAM	X	✓
AIRE COMPRIMIDO COMPRESSED AIR	X	✓
ARGÓN ARGON	✓	✓
DIÓXIDO DE CARBONO CARBON DIOXIDE	✓	✓
ETILENGLICOL ETILENGLICOL	✓	✓
PROPILENGLICOL PROPILENGLICOL	✓	✓
NITRÓGENO NITROGEN	✓	✓
BENZENO BENZENE	X	✓
GASOLINA GASOLINE	X	✓
GASOIL/DIESEL/FUELOIL DIESEL	X	✓
HIDRÓXIDO SÓDICO SODIUM HYDROXIDE	✓	✓
METANOL METANOL	✓	✓
TETRACLOROETILENO TETRACHLORETHYLENE	X	✓
XILENO XYLENE	X	✓

- X Incompatible / Non suitable
- ✓ Compatible / Suitable

APLICACIONES APPLICATIONS

APLICACIÓN	TUBERÍA	JUNTA	PRESIÓN MÁX. (BAR)	T (°C)
APPLICATION	PIPE	GASKET	MAX. PRESSURE (BAR)	T (°C)
AGUA POTABLE DRINKABLE WATER	AISI-316L	EPDM	16 BAR	0/+120°C
CALEFACCIÓN HEATING SYSTEMS	AISI-304L/AISI-316L	EPDM	16 BAR	0/+120°C
SISTEMAS ANTIINCENDIOS FIREFIGHTING SYSTEMS	AISI-304L/AISI-316L	EPDM	12,5 BAR	AMBIENTE ROOM TEMP.
REFRIGERACIÓN AIR COOLING	AISI-304L/AISI-316L	EPDM	16 BAR	-20/+120°C
SOLAR SOLAR POWER	AISI-304L/AISI-316L	FKM	6 BAR	-20/+180°C
AIRE COMPRIMIDO COMPRESSED AIR	AISI-304L/AISI-316L	EPDM/FKM	16 BAR (DN15-DN54) 10 BAR (DN76-DN108)	AMBIENTE ROOM TEMP.
NITRÓGENO NITROGEN (GAS)	AISI-316L	EPDM	16 BAR (DN15-DN54) 10 BAR (DN76-DN108)	AMBIENTE ROOM TEMP.
ARGÓN ARGON (GAS)	AISI-316L	EPDM	16 BAR (DN15-DN54) 10 BAR (DN76-DN108)	AMBIENTE ROOM TEMP.
DIÓXIDO CARBONO CARBON DIOXIDE (GAS)	AISI-304L/AISI-316L	EPDM	16 BAR (DN15-DN54) 10 BAR (DN76-DN108)	AMBIENTE ROOM TEMP.
VAPOR STEAM	AISI-316L	FKM	1 BAR	MAX. +120°C
VACÍO VACUUM	AISI-304L/AISI-316L	EPDM	-0,8 BAR	AMBIENTE ROOM TEMP.

- Las aplicaciones y los valores descritos en esta tabla son orientativos y basadas en las instalaciones ya realizadas y supervisadas por MT Valves and Fittings y que están funcionando correctamente.
The applications and values described in this table are indicative and based on the installations already carried out and supervised by MT Valves and Fittings and that are functioning correctly.

UAP432CFM

MÁQUINA DE PRENSAR ELECTRO HIDRÁULICA CON BLUETOOTH Y PANTALLA OLED / ELECTROHYDRAULIC MACHINE FOR PRESS WITH BLUETOOTH AND OLED SCREEN



CÓDIGO	€
CODE	€

UAP432CFM Consultar

- Se suministra con: maletín, máquina, cargador (LGL1), una batería (18V/3) y un adaptador enchufable (NG2230).
- Admite mordazas desde 15 a 108.
Supplied with: briefcase, machine, charger (LGL1), a battery (18V/3) and a plug-in adapter (NG2230). Accepts jaws from 15 to 108.

SBM

MORDAZA DE PRENSAR
PRESSING JAW



CÓDIGO	MEDIDA	€
CODE	SIZE	€

SB15M	15	Consultar
SB18M	18	Consultar
SB22M	22	Consultar
SB28M	28	Consultar
SB35M	35	Consultar

- Perfil M
M profile

BPLP

CADENA DE PRENSADO
PRESSING CHAIN



CÓDIGO	MEDIDA	€
CODE	SIZE	€

BP761LP	76,1	Consultar
BP889LP	88,9	Consultar
BP108LP	108	Consultar

- Baja presión 48Bar
Low pressure 48Bar

SSKMN

CADENA DE PRENSADO
PRESSING CHAIN



CÓDIGO	MEDIDA	€
CODE	SIZE	€

SSK42	42	Consultar
SSK54	54	Consultar

- Perfil M
M profile

SBK4254

MORDAZA ADAPTADORA
ADAPTER JAW

CÓDIGO	MEDIDA	€
CODE	SIZE	€
SBK4254	42-54	Consultar

SBKUAP4

MORDAZA ADAPTADORA
ADAPTER JAW

CÓDIGO	MEDIDA	€
CODE	SIZE	€
SBKUAP4	76-88-108	Consultar

PACK MAP
2L19MALETÍN PACK MAQUINARIA PRESS MAP2L19
BRIEFCASE MACHINE PRESS PACK MAP2L19**Klauke**
A Textron Company

CÓDIGO	MEDIDA	€
CODE	SIZE	€
PACKMAP2L19	15-35 (M)	Consultar

- Se suministra con: maletín, máquina, cargador, una batería y mordazas 15-18-22-28-35.

Supplied with: case, machine, charger, battery and clamps 15-18-22-28-35.

160101

ABARCÓN ACERO AL CARBONO CINCADO
U-BOLT CARBON STEEL GALVANIZED



CÓDIGO	MEDIDA			€
CODE	SIZE			€
160101-008	1/4"	600	1	0,23
160101-010	3/8"	600	1	0,23
160101-015	1/2"	600	1	0,29
160101-020	3/4"	600	1	0,34
160101-025	1"	600	1	0,36
160101-032	1 1/4"	600	1	0,40
160101-040	1 1/2"	300	1	0,52
160101-050	2"	200	1	0,60
160101-065	2 1/2"	150	1	1,09
160101-080	3"	125	1	1,17
160101-090	3 1/2"	125	1	1,29
160101-100	4"	100	1	1,38
160101-125	5"	125	1	1,68
160101-150	6"	50	1	1,82
160101-200	8"	50	1	2,34

160204

AISI 304 (A2)

ABARCÓN ACERO INOXIDABLE
U-BOLT STAINLESS STEEL



CÓDIGO	MEDIDA			€
CODE	SIZE			€
160204-008	1/4"	100	1	1,11
160204-010	3/8"	100	1	1,11
160204-015	1/2"	100	1	1,17
1602 04-020	3/4"	100	1	1,22
160204-025	1"	100	1	1,32
160204-032	1 1/4"	100	1	1,48
160204-040	1 1/2"	100	1	2,47
160204-050	2"	100	1	2,66
160204-065	2 1/2"	50	1	4,55
160204-080	3"	50	1	4,65
160204-090	3 1/2"	50	1	4,93
160204-100	4"	50	1	5,29
160204-125	5"	50	1	6,07
160204-150	6"	25	1	6,81
160204-200	8"	25	1	8,11

160306

AISI 316 (A4)

ABARCÓN ACERO INOXIDABLE
U-BOLT STAINLESS STEEL



CÓDIGO	MEDIDA			€
CODE	SIZE			€
160306-008	1/4"	100	1	1,78
160306-010	3/8"	100	1	1,78
160306-015	1/2"	100	1	1,87
160306-020	3/4"	100	1	1,96
160306-025	1"	100	1	2,10
160306-032	1 1/4"	100	1	2,36
160306-040	1 1/2"	100	1	3,96
160306-050	2"	100	1	4,26
160306-065	2 1/2"	50	1	6,66
160306-080	3"	50	1	7,43
160306-090	3 1/2"	50	1	7,88
160306-100	4"	50	1	8,47
160306-125	5"	50	1	9,72
160306-150	6"	25	1	10,90
160306-200	8"	25	1	12,97

FICHA TÉCNICA PARA ABARCÓN

TECHNICAL DATA SHEET FOR U-BOLT

SIZE	B	C	E	M
1/4"	32	20	14	M6
3/8"	37	23,5	15	M6
1/2"	42	28	17	M6
3/4"	50	34	19	M6
1"	62	41	24	M6
1 1/4"	71	49	24	M6
1 1/2"	80	57	26	M8
2"	91	70	26	M8
2 1/2"	117,5	85	35	M10
3"	130,5	101	35	M10
3 1/2"	143	114	35	M10
4"	155	127	35	M10
5"	186	154	40	M10
6"	213	232	40	M10
8"	264	286	40	M10

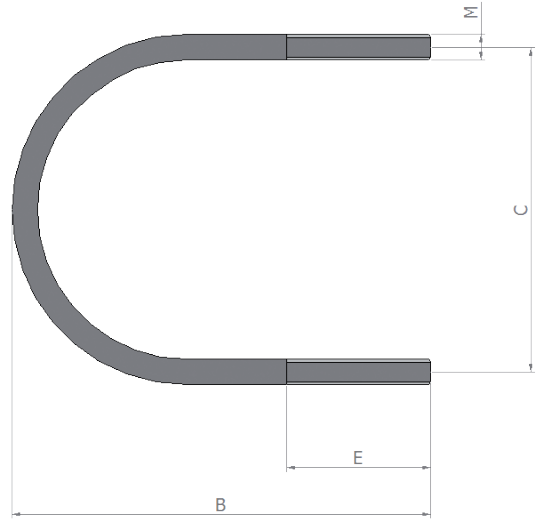



LÍMITES TÉCNICOS

Temperatura ambiente:
de -20°C a +60°C

Temperatura de proceso:
hasta +60°C

Se recomienda que la presión de trabajo sea inferior al 75% del rango total para presiones sostenidas y 65% para presiones fluctuantes.

TECHNICAL LIMITS

Ambient Temperature:
from -20°C to +60°C

Process Temperature:
until +60°C

Recommended maximum working pressure must be less than 75% of the total range for sustained pressure and 65% for fluctuating pressures.

LEYENDA DE ICONOS
ICON KEY

Posibles codificaciones
aplicadas en esta sección.

Possible encodings applied
in this section.

 INOX

Inoxidable
Stainless steel



Código de barras EAN
EAN bar code

PROPIEDADES DE PRODUCTO
PRODUCT PROPERTIES**CARACTERÍSTICAS:**

Acorde con EN837-1
Escala de medida positiva y dual, unidades:
Bar/psi
Manómetro analógico
8400 - 8500 Rosca 1/4"
BSP macho
8599 - 8799 Rosca 1/4"
BSP macho
8600 - 8800 Rosca 1/2"
BSP macho

FEATURES:

Following EN837-1
Positive and Dual Scale units:
Bar/psi
Analog manometers
8400 - 8500 Thread 1/4"
BSP male
8599 - 8799 Thread 1/4"
BSP male
8600 - 8800 Thread 1/2"
BSP male

INDUSTRIAL**MANÓMETROS**
PRESSURE GAUGES

8400

MANÓMETRO ESFERA SECA DN50 CONEXIÓN POSTERIOR LATÓN 1/4"
 DRY SPHERE PRESSURE GAUGE DN50 BRASS BACK CONNECTION 1/4"



CÓDIGO	BAR	DIAL (BAR)			€
CODE	BAR	DIAL (BAR)			€
8400-02	0-2,5	0.1	60	1	4,18
8400-04	0-4	0.1	60	1	4,18
8400-06	0-6	0.1	60	1	4,18
8400-10	0-10	0.2	60	1	4,18
8400-16	0-16	0.2	60	1	4,18

8500

MANÓMETRO ESFERA SECA DN50 CONEXIÓN INFERIOR LATÓN 1/4"
 DRY SPHERE PRESSURE GAUGE DN50 BRASS BOTTOM CONNECTION 1/4"



CÓDIGO	BAR	DIAL (BAR)			€
CODE	BAR	DIAL (BAR)			€
8500-02	0-2,5	0.1	72	1	4,18
8500-04	0-4	0.1	72	1	4,18
8500-06	0-6	0.1	72	1	4,18
8500-10	0-10	0.2	72	1	4,18
8500-16	0-16	0.2	72	1	4,18

8599

MANÓMETRO ACERO INOXIDABLE GLICERINA DN63 CONEXIÓN INFERIOR LATÓN 1/4"
 STAINLESS STEEL GLYCERINE FILLED PRESSURE GAUGE DN63 BRASS BOTTOM CONNECTION 1/4"



CÓDIGO	BAR	DIAL (BAR)			€
CODE	BAR	DIAL (BAR)			€
8599-02	0-2,5	0.05	54	1	10,23
8599-04	0-4	0.1	54	1	10,23
8599-06	0-6	0.1	54	1	10,23
8599-10	0-10	0.2	54	1	10,23
8599-16	0-16	0.2	54	1	10,23
8599-25	0-25	0.5	54	1	10,23
8599-40	0-40	1.0	54	1	10,23
8599-60	0-60	1.0	54	1	10,23
8599-100	0-100	2.0	54	1	10,23

8799

MANÓMETRO ACERO INOXIDABLE GLICERINA DN63 CONEXIÓN INFERIOR INOXIDABLE 1/4"
 STAINLESS STEEL GLYCERINE FILLED PRESSURE GAUGE DN63 STAINLESS STEEL BOTTOM CONNECTION 1/4"



CÓDIGO	BAR	DIAL (BAR)			€
CODE	BAR	DIAL (BAR)			€
8799-02	0-2,5	0.1	54	1	22,57
8799-04	0-4	0.1	54	1	22,57
8799-06	0-6	0.1	54	1	22,57
8799-10	0-10	0.2	54	1	22,57
8799-16	0-16	0.2	54	1	22,57
8799-25	0-25	1.0	54	1	22,57
8799-40	0-40	2.0	54	1	22,57
8799-60	0-60	2.0	54	1	22,57
8799-100	0-100	5.0	54	1	22,57

8600

MANÓMETRO ACERO
INOXIDABLE GLICERINA
DN100 CONEXIÓN INFERIOR
LATÓN 1/2"

STAINLESS STEEL GLYC-
ERINE FILLED PRESSURE
GAUGE DN100 BRASS
BOTTOM CONNECTION 1/2"



CÓDIGO	BAR	DIAL (BAR)			€
CODE	BAR	DIAL (BAR)			€
8600-06	0-6	0.1	16	1	21,00
8600-10	0-10	0.2	16	1	21,00
8600-16	0-16	0.2	16	1	21,00
8600-40	0-40	1.0	16	1	21,00
8600-100	0-100	2.0	16	1	21,00

- Caja acero inoxidable
Stainless steel case

8800

MANÓMETRO ACERO
INOXIDABLE GLICERINA
DN100 CONEXIÓN INFERIOR
INOXIDABLE 1/2"

STAINLESS STEEL GLYC-
ERINE FILLED PRESSURE
GAUGE DN100 STAINLESS
STEEL BOTTOM
CONNECTION 1/2"



CÓDIGO	BAR	DIAL (BAR)			€
CODE	BAR	DIAL (BAR)			€
8800-06	0-6	0.1	16	1	40,13
8800-10	0-10	0.2	16	1	40,13
8800-16	0-16	0.2	16	1	40,13
8800-40	0-40	1.0	16	1	40,13
8800-100	0-100	2.0	16	1	40,13

- Caja acero inoxidable
Stainless steel case

CONDICIONES DE VENTA

TERMS & CONDITIONS

CONDICIONES VÁLIDAS SÓLO PARA ESPAÑA VALID CONDITIONS ONLY IN SPAIN

PRECIOS Y CONDICIONES DE PAGO

Contado: reposición o recibo a 15 días dto. P.P. 1%.

Forma de pago: plazo máximo 60 días fecha factura.

IVA: se cargará el % correspondiente, según reglamentación en vigor.

Tarifas de precios: nos comprometemos a comunicar a nuestros clientes cualquier cambio que se produzca en las tarifas del catálogo a través de las usuales vías de comunicación: web, email, correo.

PEDIDOS

Con el fin de evitar confusiones y ofrecer un mejor servicio, será condición indispensable por parte del comprador indicar la referencia MT Business Key, S.L. en su pedido, incluidos los dígitos de la medida. Cada pedido enviado a MT Business Key, S.L. genera una expedición para el cliente, recomendamos que preparen sus pedidos completos para optimizar los gastos de transporte. Todos los pedidos serán confirmados vía email y, salvo notificación de lo contrario, seguirá su curso sin derecho a posteriores modificaciones.

Pedido mínimo aceptable: 150€ netos.

Cantidades mínimas: las cantidades mínimas aceptables corresponderán a las del embalaje interior de la caja.

Embalajes: incluidos.

PORTES

Se cargarán 7€ en factura para pedidos inferiores a los 400 € netos (Península y Baleares). Para el resto del territorio se cargarán los portes en factura aplicando la tarifa reducida de nuestra agencia de transportes.

España (Península) e Islas Baleares: incluidos en pedidos superiores a 400€ netos.

Melilla: incluidos en pedidos superiores a 1200€ netos.

Islas Canarias: incluidos en pedidos superiores a 800€ netos.

CONDICIONES VÁLIDAS SÓLO PARA EXPORTACIÓN VALID CONDITIONS ONLY FOR EXPORT

RATES AND FREIGHTS CONDITIONS

Cash: bank transfer. For advance payments discount 1%.

Credit: max. 60 days invoice date after Bank Insurance Approval.

Freight Conditions: EXW Incoterms 2010, unless other conditions are granted.

Price rates: MT Business Key, S.L. commits to communicate to our customers any changes applied on tariffs through usual means of communication: web & email.

ORDERS

Minimum order amount: 500€ netto.

Minimum quantities: the minimum acceptable quantities will be equal to inner packing quantities.

Packing: included.

CUSTOMER SERVICE

Claims: all claims will be granted within 45 days after date of Invoice. After this period MT Business Key, S.L. can't promise any resolution.

Warranty: all our products are new and are covered for 2 years.

Return policy: all material returned will be at freight paid. All products must be in original conditions and clearly identified. If after inspection in our warehouse these products are not in original condition, we might apply a devaluation fee.

SERVICIOS POSTVENTA OFRECIDOS POR MT:

Reclamaciones: cualquier reclamación deberá formularse dentro de los treinta (30) días siguientes a la fecha de factura, rechazándose las efectuadas después de dicho plazo límite.

Periodo de desistimiento: conforme la Ley General para la Defensa de los Consumidores y Usuarios, el comprador dispone de catorce (14) días naturales para devolver la totalidad o parte del pedido sin penalización alguna, a contar desde la fecha de factura.

Devoluciones: no se aceptará ninguna devolución de material sin antes existir la conformidad expresa, mediante el número de devolución facilitado, por la empresa (*véase nuestra política y proceso de devolución en la web*). El plazo máximo admitido para devolver material no conforme es de sesenta (60) días, a contar desde la fecha de factura.

Garantía: todos nuestros productos tienen 2 años de garantía según establece la Ley vigente. Si el defecto se manifiesta pasados los 6 meses después de su compra se requerirá una revisión técnica y/o pericial por nuestro departamento de calidad con tal de poder aplicar su derecho a la garantía.

La garantía queda limitada pura y simplemente al reemplazo de las piezas, una vez reconocidas materialmente defectuosas por nuestro personal técnico sin indemnización.

Litigios: en caso de litigio ambas partes aceptan someter sus diferencias a los juzgados y tribunales de Barcelona.

MT Business Key S.L. se reserva la facultad de cambiar en todo o en parte el diseño, materiales, embolsado, encajado y precios de cualquiera de sus productos.

CONDITIONS INSIDE EU:

Even though all purchases are covered by our extended 14-day exchange or refund promise, no material return will be accepted without the conformity of the commercial department.

No unwanted material returned will be accepted after 60 days invoice's date. All unwanted material returned after 14 days of date of invoice and before maximum period of acceptance (60 days) will be charged 30% of demerit.

CONDITIONS OUTSIDE EU:

No unwanted material returned will be accepted after 90 days invoice's date. All unwanted material returned will be charged 30% of demerit.

Litigations: in case of litigation both sides agree to take their differences at the courts of Barcelona.

MT Business Key S.L. reserves the right to modify all or part of the design, materials, packing or prices of any of their products.

**Nuevo servicio urgente 24 horas sólo para España**

Para paquetería de menos de 10 kg. 7 € en factura.

Para expediciones de menos de 30 kg. 12 € en factura.

Para pedidos superiores a 30 kg de peso, consultar.

New urgent service 24 hours only in Spain

For packages of less than 10 kg. 7 € in invoice

For expeditions of less than 30 kg. 12 € in invoice

For higher orders to 30 kg weight, consult.

ÍNDICE DE REFERENCIAS

REFERENCES INDEX

REF	PAG	REF	PAG	REF	PAG
0909	16	5118	55	8601	194
0910	20	5119	57	8602	194
0911	24	5120	160	8799	228
0912	26	5121	161	8800	229
0913	53	5125	72	09102	20
0914	40	5126	162	09103	22
0915	41	5128	51	09104	22
0916	54	5130	82	015004	219
0917	18	5131	86	015006	219
0918	32	5132	45	51142	98
0919	34	5137	88	51143	112
0921	42	5140	100	51151	104
0926	44	5141	102	51202	160
01001	207	5142	74	51212	161
01002	207	5143	80	51224	116
01003	208	5144	114	51302	85
01040	206	5145	90	80902	182
01041	206	5146	79	91020	28
01090	208	5200	118	91031	36
01092	209	5300	121	91032	38
01130	209	5324	121	91120	30
01131	210	8090	182	160101	224
01132	211	8092	183	160204	224
01246	212	8120	183	160306	224
01270	212	8130	184	310912	47
01290	213	8132	184	540032	119
01321	215	8149	185	540052	119
01340	213	8150	185	2642024	176
01341	214	8180	186	2642026	176
01359	214	8240	186	0912 - 5100912	152
01360	215	8241	187	0912 - 5200912	152
01440	216	8245	188	0912 - 5300912	153
01441	216	8270	189	0912 - 5320912	153
01472	217	8280	189	0917 - 5100917	138
4104	60	8290	190	0917 - 5200917	138
4114	66	8300	190	0917 - 5300917	139
4204	61	8312	191	0917 - 5320917	139
4504	62	8330	191	0918 - 5100918	140
4604	63	8340	192	0918 - 5200918	140
5100	118	8341	193	0918 - 5300918	141
5110	68	8399	192	0918 - 5320918	141
5113	75	8400	228	0919 - 5100919	142
5114	94	8500	228	0919 - 5200919	142
5115	108	8531	193	0919 - 5300919	143
5116	70	8599	228	0919 - 5320919	143
5117	49	8600	229	41131	64

REF	PAG
5114 - 5105114	124
5114 - 5205114	124
5114 - 5305114	125
5114 - 5325114	125
51142 - 51051142	132
51142 - 52051142	132
51142 - 53051142	133
51142 - 53251142	133
51143 - 51051143	136
51143 - 52051143	136
51143 - 53051143	137
51143 - 53251143	137
5114MR	96
5115 - 5205115	126
5115 - 5305114	126
5115 - 5305115	127
5115 - 5325115	127
51151 - 51051151	128
51151 - 52051151	128
51151 - 53051151	129
51151 - 53251151	129
51151MR	106
5115MR	100
5117 - 5105117	144
5117 - 5205117	144
5117 - 5305117	145
5117 - 5325117	145
5128 - 5105128	146
5128 - 5205128	146
5128 - 5305128	147
5128 - 5325128	147
5140 - 5105140	130
5140 - 5205140	130
5140 - 5325140	131
5140 - 5325140	131
5144 - 5105144	134
5144 - 5205144	134
5144 - 5305144	135
5144 - 5325144	135
5144MR	114
51BSR	122
51CFC	120
51DPS	122
51SMC	120
91020 - 51091020	150
91020 - 52091020	150
91020 - 53091020	151
91020 - 53291020	151
91031 - 51091031	154
91031 - 52091031	154
91031 - 53091031	155

REF	PAG
91031 - 53291031	155
91032 - 51091032	156
91032 - 52091032	156
91032 - 53091032	157
91032 - 53291032	157
91120 - 51091120	148
91120 - 52091120	148
91120 - 53091120	149
91120 - 53291120	149
BL1506	178
BPLP	222
EN-1092-1 TYPE:01A PN-10	166
ISO EN 1.4307/A-304L	
EN-1092-1 TYPE:01A PN-10	166
ISO EN 1.4404/A-316L	
EN-1092-1 TYPE:01A PN-10	165
MM EN 1.4307/A-304L	
EN-1092-1 TYPE:01A PN-10	165
MM EN 1.4404/A-316L	
EN-1092-1 TYPE:01A PN-16	170
ISO EN 1.4307/A-304L	
EN-1092-1 TYPE:01A PN-16	170
ISO EN 1.4404/A-316L	
EN-1092-1 TYPE:01A PN-16	169
MM EN 1.4307/A-304L	
EN-1092-1 TYPE:01A PN-16	169
MM EN 1.4404/A-316L	
EN-1092-1 TYPE:05A PN-10	171
EN 1.4404/A-316L	
EN-1092-1 TYPE:05A PN-10	171
EN 1.4307/A-304L	
EN-1092-1 TYPE:05A PN-16	171
EN 1.4404/A-316L	
EN-1092-1 TYPE:11B PN-16	173
EN 1.4307/A-304L	
EN-1092-1 TYPE:11B PN-16	173
EN 1.4404/A-316L	
EN-1092-1 TYPE:13B EN	167
1.4404/A-316L	
EN-1092-1 TYPE:13B EN	167
1.4307/A-304L	
JE	218
JV	218
LJ1506	178
PACK MAP 2L19	223
S09014	196
S09016	196
S09046	197
S13014	197
S13016	198
S13046	199
S24014	202

REF	PAG
S24016	203
S24046	204
S29014	198
S29016	199
S29046	200
S29614	201
S29616	200
S29646	201
S525604	175
S525606	175
SBK4254	223
SBKUAP4	223
SBM	222
SO1506	178
SSKMN	222
SW1506	179
UAP432CFM	222
WN1506	178

DICCIONARIO TECNICO

FORMACIÓN BÁSICA DE CONCEPTOS Y PRODUCTOS

CONCEPTOS

DN

Abreviación de Diámetro Nominal. Indica el diámetro interior de paso del fluido por dentro de tuberías, válvulas o accesorios.

PN

Abreviación de Presión Nominal. Indica la presión interior máxima de trabajo en condiciones de temperatura ambiente y presión exterior atmosférica. El límite de presión de trabajo es una curva que va decreciendo en función del aumento de temperatura. La correcta aplicación de una válvula se realiza primero con la determinación de las condiciones de temperatura y presión y su comprobación de que el punto de trabajo siga dentro de las condiciones mecánicas de funcionamiento de esta.

PÉRDIDA DE CARGA

Disminución de la energía dinámica del fluido producido por la fricción con las paredes, su propia fricción entre sus partículas. Los cambios bruscos de dirección o de diámetro aumentan las pérdidas de carga de manera significativa.

GOLPE DE ARIETE

Fenómeno de aumento excesivo de la presión producido en las instalaciones hidráulicas cuando hay un cierre brusco del caudal del fluido. Es un fenómeno peligroso pues las presiones pueden aumentar muy por encima de las presiones nominales de los componentes y producir roturas en tuberías, accesorios y/o válvulas. La forma de evitar estos golpes de ariete es ralentizar el cierre de las válvulas o instalar algún mecanismo que pueda absorber el exceso de presión (Vasos de expansión, dispositivos antiariete como el de MT modelo 4160).

PASO TOTAL

Una válvula se puede considerar de Paso Total o Paso Completo cuando el paso del fluido es igual a su DN (Diámetro nominal). Según UNE-EN-13828.

PASO REDUCIDO

Una válvula se puede considerar de Paso Reducido cuando el paso del fluido es una medida inferior a su DN (diámetro nominal). Según UNE-EN-13828.

ESTANQUEIDAD

Concepto que nos indica que no pasa fluido a través de la válvula en posición de cierre ni por cualquier otro punto (eje, unión cuerpo-tapa, etc).

PAR DE GIRO

Fuerza medida en Nm que se ejerce para la apertura y cierre de la válvula. Es importante su valor para poder dimensionar correctamente un actuador. Las condiciones de trabajo, presión, temperatura, presión diferencial, densidad del fluido y viscosidad del fluido puede modificar significativamente el par de giro por lo que como mínimo se debe de tener un margen de seguridad del 30%.

TECHNICAL DICTIONARY

BASIC TRAINING OF CONCEPTS AND PRODUCTS

CONCEPTS

DN

Abbreviation of Nominal Diameter. Indicates the internal diameter of fluid passage through pipes, valves or fittings.

PN

Abbreviation of Nominal Pressure. Indicates the maximum internal working pressure under ambient temperature and atmospheric external pressure. The working pressure limit is a curve that decreases depending on the temperature increase. The correct application of a valve is first carried out with the determination of the temperature and pressure conditions and its verification that the working point remains within its mechanical operating conditions.

HEAD LOSS

Reduction of the dynamic energy of the fluid produced by friction with the walls, its own friction between its particles. Sudden changes in direction or diameter increase load losses significantly.

WATER HAMMER

Phenomenon of excessive increase of the pressure produced in the hydraulic installations when there is an abrupt closure of the fluid flow. It is a dangerous phenomenon because the pressures can increase well above the nominal pressures of the components and cause breaks in pipes, fittings and / or valves.

The way to avoid these water hammers is to slow down the closing of the valves or install some mechanism that can absorb excess pressure (expansion vessels, anti-cracking devices such as MT model 4160).

FULL BORE

A valve can be considered as Total Pass or Full Pass when the fluid flow is equal than its DN (Nominal Diameter). According to UNE-EN-13828.

REDUCED BORE

A valve can be considered a Reduced Pass when the fluid flow is one size smaller than its DN (Nominal Diameter). According to UNE-EN-13828.

SEALING

Concept that indicates that no fluid passes through the valve in the closed position or any other point (stem, body-cover joint, etc).

TORQUE

Force measured in Nm used to open or closing the valve. Its value is important in order to determinate the correct size for actuator. The working conditions, pressure, temperature, differential pressure, fluid density and fluid viscosity can significantly change the torque so that at least a safety margin of 30% must be had.

MATERIALES

HIERRO

Metal común frágil y con poca resistencia de la dureza y oxidación. En nuestro caso, lo galvanizamos (tratamiento químico), para darle una mayor resistencia a la oxidación.

LATÓN

El latón es una aleación de Cobre y Zinc. Muy usado en valvulería para edificación por su facilidad de manipulación combinada a su características mecánicas y su resistencia a la oxidación.

Propiedades:

- Buena resistencia a la oxidación.
- Excelente mecanización en frío.
- Excelente capacidad de recubrirse, como niquelados, galvanizados y cromados
- Excelente soldabilidad.

Existen diferentes tipos de latones, las normas que los definen son la EN-12164, EN-12165.

La tendencia actual en Europa es la de cambiar a latones tipo DZR con mayores propiedades oxidantes y latones con menores o nulas cantidades de plomo.

ACERO INOXIDABLE

Los productos de MT utilizan básicamente dos tipos de Aceros Inoxidable. Se usan para válvulas que la exigencia mecánica alta, y el fluido y ambiente son corrosivos.

A304, A304L: Acero Inoxidable Austenítico con unas buenas propiedades oxidante.

A316, A316L: Acero Inoxidable Austenítico con unas mejores propiedades oxidante que el A304 por la adición de Molibdeno.

Propiedades:

- Excelente resistencia a la oxidación.
- Buena mecanización en frío.
- Buena soldabilidad en las versiones "L" de bajo contenido en carbono (A304L y A316L)
- Muy buenas propiedades mecánicas. Gran tenacidad.

Las condiciones mecánicas de estos aceros pueden variar según la forma de enfriamiento y por los tratamientos térmicos. La norma EN-10088 los describe.

FUNDICIÓN GRIS

Aleación de hierro, carbono y otros elementos en menores cantidades. Se usa para válvulas que la exigencia mecánica no sea grande, y el fluido y ambiente no son corrosivos. Propiedades:

- Baja resistencia a la oxidación.
- Baja dureza.
- Frágilidad media.
- Buenas propiedades mecánicas.
- Excelente mecanización en frío.

Las válvulas de fundición gris van recubiertas por pinturas epoxi para mejorar notablemente su resistencia a la oxidación.

FUNDICIÓN NODULAR O DÚCTIL

Aleación de hierro, carbono y otros elementos en menores cantidades. Aumento de la Dureza y la resistencia a la fatiga.

Se usa para válvulas que la exigencia mecánica es medias, y el fluido y ambiente no son corrosivos.

Propiedades:

- Baja resistencia a la oxidación.
- Mejora la dureza de la fundición gris.
- Mejora la fragilidad de la fundición gris.
- Buenas propiedades mecánicas, mejores que la fundición gris.
- Excelente mecanización en frío.

Las válvulas de fundición dúctil también van recubiertas por pinturas epoxi para mejorar notablemente su resistencia a la oxidación.

ACERO AL CARBONO

Aleación de hierro con carbono. A diferencia de los aceros inoxidables tiene pocos elementos aleados. Son el tipo de aceros más producidos a nivel mundial.

Se usa para válvulas que necesitan unas propiedades mecánicas exigentes.

Propiedades:

- Baja resistencia a la oxidación.
- Mejora la dureza de la fundición gris.
- Mejora la fragilidad de la fundición gris.
- Buenas propiedades mecánicas, mejores que la fundición gris.
- Buena mecanización en frío.

Las válvulas de acero al carbono suelen protegerse con aceites y algunas con pintura epoxi para aumentar su resistencia a la oxidación.

NBR

Caucho de Nitrilo Butadieno (**N**itrile **B**utadiene **R**ubber). Elastómero procedente de caucho.

Propiedades:

- Compatible con hidrocarburos, petróleo y gasóleos.
- Compatible con agua para suministro humano.
- Las temperaturas de utilización van de los -20°C a los 80°C
- Gran resistencia a las deformaciones.
- Buena resistencia a la abrasión.

Algunas válvulas lo usan para sellar el eje en forma de junta tórica o en junta plana.

EPDM

Etileno Propileno Dieno tipo **M**, elastómero sintético.

Propiedades:

- No es compatible con hidrocarburos, petróleo y gasóleos.
- Compatible con agua para suministro humano.
- Las temperaturas de utilización van de los -20°C a los 120°C.
- Gran resistencia a las deformaciones.
- Buena resistencia a la abrasión.

Algunas válvulas lo usan para sellar el eje en forma de junta tórica o en junta plana.

FKM

Elastómero fluoropolímero.

Propiedades:

- Compatible con hidrocarburos, petróleo y gasóleos.

MATERIALS

IRON

Common metal fragile and with little resistance to hardness and oxidation. In our case, we galvanize it (chemical treatment), to give it greater resistance to oxidation.

BRASS

Brass is an alloy of Copper and Zinc. Widely used in building valves for ease handling combined with its mechanical properties and oxidation resistance.

Properties:

- Good oxidation resistance.
- Excellent cold machining.
- Excellent coating ability, such as nickel plated, galvanized and chrome plated.
- Excellent weldability.

There are different types of brass, the standards defining them are EN-12164, EN-12165.

The current trends in Europe are to switch to brass type DZR with higher oxidizing properties and brass with less or no lead content.

STAINLESS STEEL

MT products use basically two types of stainless steels. They are used for valves with high mechanical requirements, and the fluid and environment are corrosive.

A304, A304L: Austenitic Stainless Steel with good oxidizing properties.

A316, A316L: Austenitic Stainless Steel with better oxidizing properties than A304 by the addition of Molybdenum.

Properties:

- Excellent resistance to oxidation.
- Good cold machining.
- Good weldability in low carbon "L" versions (A304L and A316L)
- Very good mechanical properties. Great tenacity.

The mechanical conditions of these steels may vary depending on the form of cooling and the heat treatment. The standard EN-10088 describes them.

CAST IRON

Alloying of iron, carbon and other elements in smaller quantities. It's used for valves where the mechanical requirement is not large and the fluid and environment are not corrosive. Properties:

- Low resistance to oxidation.
- Low hardness.
- Medium fragility.
- Good mechanical properties.
- Excellent cold machining.

Cast iron valves are coated with epoxy paint to significantly improve their resistance to oxidation.

NODULAR OR DUCTILE IRON

Alloying of iron, carbon and other elements in smaller quantities. Increased hardness and fatigue resistance than cast iron.

It is used for valves whose mechanical requirements are average, and the fluid and environment are not corrosive.

Properties:

- Low resistance to oxidation.
- Improves the hardness of the gray foundry.
- Improves the fragility of the gray foundry.
- Good mechanical properties, better than the gray foundry.
- Excellent cold machining.

Ductile iron valves are also coated with epoxy paints to significantly improve their oxidation resistance.

CARBON STEEL

Iron alloy with carbon. Unlike stainless steels it has few alloyed elements. They are the most produced type of steels in the world. It is used for valves that require demanding mechanical properties.

Properties:

- Low resistance to oxidation.
- Improves the hardness of the gray foundry.
- Improves the fragility of the gray foundry.
- Good mechanical properties, better than the gray foundry.
- Good cold machining.

Carbon steel valves are usually protected with oils and some with epoxy paint to increase their resistance to oxidation.

NBR

Nitrile **B**utadiene **R**ubber. Elastomer from rubber.

Properties:

- Compatible with hydrocarbons, oil and diesel.
- Compatible with water for human supply.
- The operating temperatures range from -20°C to 80°C.
- High resistance to deformations.
- Good abrasion resistance.

Some valves use it to seal the shaft in the form of a O-ring or a flat joint.

EPDM

Ethylene **P**ropylene **D**iene type **M**, synthetic elastomer.

Properties:

- Not compatible with hydrocarbons, oil and gas.
- Compatible with water for human supply.
- The operating temperatures range from -20°C to 120°C.
- High resistance to deformations.
- Good abrasion resistance.

Some valves use it to seal the shaft in the form of a O-ring or a flat joint.

FKM

Fluoropolymer elastomer.

Properties:

- Compatible with hydrocarbons, oil and diesel.
- Compatible with water for human supply.
- Use temperatures range from -20°C to 180°C.
- High resistance to deformations.
- Good resistance to high temperatures.

- Compatible con agua para suministro humano.
- Las temperaturas de utilización van de los -20°C a los 180°C.
- Gran resistencia a las deformaciones.
- Buena resistencia a altas temperaturas.
- Se puede usar como cierre para válvulas en instalaciones de solar térmica.

Algunas válvulas lo usan para sellar el eje en forma de junta tórica o en junta plana.

PTFE

Elastómero sintético, **politetrafluoretileno**.

Propiedades:

- Compatible con la mayoría de químicos.
- Compatible con agua para suministro humano.

- Las temperaturas de utilización va de los -270°C a los 280°C
- Buena resistencia a temperaturas cercanas al cero absoluto y a altas temperaturas.
- Es el material con el menor coeficiente de fricción conocido.
- Se puede usar como cierre para válvulas en instalaciones de solar térmica.
- Fácil mecanización.
- Se puede mezclar con grafito o fibra de vidrio para mejorar sus propiedades mecánicas.

Algunas válvulas lo usan para sellar el eje en forma de junta plana.

Can be used as a shutoff for valves in solar thermal installations. Some valves use it to seal the shaft in the form of a O-ring or a flat joint.

PTFE

Synthetic elastomer, **polytetrafluoroethylene**.

Properties:

- Compatible with most chemicals.
- Compatible with water for human supply.
- The operating temperatures range from -270°C to 280°C.

- Good resistance to temperatures close to absolute zero and high temperatures.
- It's the material with the lowest known coefficient of friction.
- Can be used as a valve closure in solar thermal installations.
- Easy machining.
- Can be mixed with graphite or fiberglass to improve its mechanical properties.

Some valves use it to seal the shaft in the form of a flat joint

COMPUESTO QUÍMICO	FORRO INTERIOR DE LA JUNTA DE EXPANSIÓN			
	NBR	EPDM	FKM	PTFE
	NITRIL	EPDM	VITON	TEFLÓN
Aceite hidráulico (petróleo)	A	X	A	A
Aceite de linaza	A	B	A	A
Aceite de oliva	A	C	A	A
Aceites de petróleo con alto contenido aromático	B	X	A	A
Aceites de petróleo con bajo contenido aromático	A	X	A	A
Aceite de resina	A	X	A	A
Aceite lubricación	A	X	A	A
Aceite para transformadores	X	X	A	A
Aceite para transformadores de base mineral	A	X	A	A
Aceites vegetales	A	X	A	A
Acetaldehido D	X	B	A	A
Acetato	X	A	X	A
Acetato de butilo	X	B	X	A
Acetato de etilo	X	B	X	A
Acetileno	A	A	A	A
Acetona	X	A	X	A
Acido Acético 5%	B	A	A	A
10%	B	A	A	A
20%	B	A	B	A
30%	B	A	B	A
50%	C	A	C	A
Glacial 99,5%	C	B	X	A
Acido acético anhidro	X	A	X	A
Acido arsénico	B	A	A	A
Acido bromhidrico, max 40°C	C	A	B	A
Acido clorhídrico 37%	X	A	-	A
Acido clorhídrico, 37%, 70°C	X	X	X	A
Acido clorhídrico diluido	C	A	A	A
Acido clorosulfónico	X	X	C	A
Acido crómico	X	C	A	A
Acido hidrofluor-silícico, 40°C	B	A	A	A
Acido fluorhídrico 50%, 40°C	X	B	A	A
Acido fluor-silícico	B	B	A	A
Acido fórmico	X	A	X	A
Acido fosfórico 45%, 40°C	C	A	A	A
85%, 40°C	X	B	A	A
Acido láctico	A	A	A	A
Acido nítrico 20%, 40°C	X	A	A	A

COMPUESTO QUÍMICO	FORRO INTERIOR DE LA JUNTA DE EXPANSIÓN			
	NBR	EPDM	FKM	PTFE
	NITRIL	EPDM	VITON	TEFLÓN
20%, 50°C	X	B	A	A
Acido nítrico 40%, 50°C	X	C	A	A
50%, 50°C	X	X	A	A
60%, 20°C	X	X	A	A
70%, 20°C	X	X	A	A
Acido nítrico fumante	X	X	C	A
Acido oleico	A	X	A	A
Acido oxalico	C	A	B	A
Acido palmítico	A	B	A	A
Acido salicílico	B	A	A	A
Acido sulfúrico < 60%	X	B	A	A
60%, 50°C	X	B	A	A
75%, 50°C	X	B	A	A
80%, 50°C	X	C	A	A
96%, 50°C	X	C	A	A
Acido sulfúrico fumante	X	X	B	A
Acido sulfuroso	C	A	A	A
Agua destilada	A	A	A	A
Agua fría	A	A	A	A
Agua fría, destilada 100 °C	B	A	A	A
Agua residual	A	B	A	A
Agua salada	A	A	A	A
Alcohol metílico	B	A	X	-
Amonio líquido	B	A	X	A
Anilina	C	B	B	A
Argón	C	A	A	A
Azúfre derretido	X	B	A	A
Benceno (benzol)	X	X	A	A
Brandy	A	A	A	A
Brea 40°C	B	X	A	A
Bromo líquido	X	X	A	A
Butano	A	X	A	A
Butanol (alcohol butílico)	A	A	A	A
Cerveza	A	A	A	A
Cloruro de azúfre	X	X	A	A
Cloruro de etilo	B	A	A	A
Cloruro de metileno	X	X	B	A
Cloruro metílico	X	C	A	A
Detergente	A	A	A	A
Dióxido de azúfre Gas seco	X	A	A	A
Etano	A	X	A	A
Etanol (alcohol etílico)	A	A	B	A
Ethylene glycol	A	A	A	A
Eter de petróleo	B	X	A	A
Eter, éter etílico	C	X	X	A

COMPUESTO QUÍMICO	FORRO INTERIOR DE LA JUNTA DE EXPANSIÓN			
	NBR	EPDM	FKM	PTFE
	NITRIL	EPDM	VITON	TEFLÓN
Etilo glicol (Cellosolve)	C	B	C	A
Estireno 40° C	X	X	B	A
Fenol	X	C	A	A
Formaldehido	B	A	A	A
Fueloil	A	X	A	A
Furano	X	X	C	A
Furfuro	X	B	X	A
Gas amonia caliente	X	B	X	A
Gas amonio frío	A	A	X	A
Gas clorhídrico, húmedo, 40°C	X	C	C	A
Gas clorhídrico, seco, 40°C	X	C	A	A
Gas LP	A	X	A	A
Gas natural	A	X	A	A
Gas nitroso	X	C	X	B
Gasolina 100 oct	C	X	A	A
65 oct	B	X	A	A
Gasoil	A	X	A	A
Glicerina	A	A	A	A
Glucosa	A	A	A	A
Grasas animales	A	B	A	A
Hidrógeno	A	A	A	A
Hidróxido de amonio	C	A	B	A
Hipoclorito de calcio	C	A	A	A
Hipoclorito sódico < 10gr/l	C	A	A	A
Hipoclorito sódico > 10gr/l	X	B	A	A
Leche	A	A	A	A
Licor negro	A	X	A	A
Licor verde, licor blanco	A	A	A	A
Liquid manure	A	A	-	A
LP gas, propano	A	X	A	A
MEK Metil etil cetona	X	A	X	B
Metil isobutil cetona	X	B	X	A
Metil isopropil cetona	X	C	X	A
Nitrobenceno	X	B	B	A
Nitrógeno	A	A	A	A
Oxígeno	C	A	A	A
Ozono	X	B	A	A
Parafina de queroseno	A	X	A	A
Percloroetileno	C	X	A	A
Peróxido de hidrogeno, 3%, 40°C	B	A	A	A
30%, 20°C	C	B	A	A
90%, 20°C	C	-	B	A

COMPUESTO QUÍMICO	FORRO INTERIOR DE LA JUNTA DE EXPANSIÓN			
	NBR	EPDM	FKM	PTFE
	NITRIL	EPDM	VITON	TEFLÓN
Plating sol. W/o chromium	X	A	A	A
Potasa cáustica	C	B	C	A
Propanol, alcohol propílico	A	A	A	A
Rapesed oil	X	A	A	A
Salas férricas, no oxidantes	A	A	A	A
Sulfuro de hidrógeno, húmedo, 40°C	X	B	X	A
Sulfuro de hidrógeno, húmedo, 20° C	C	A	X	A
Sulfuro de hidrógeno, seco, 20°C	A	A	X	A
Solución de cloro 0,1 gr./l	A	A	A	A
Solución de cloro 0,1 - 1 gr./l	A	A	A	A
Solución de cloro 1-10 gr./l 40°C	B	B	-	-
Solución de cloro > 10 gr./l 40°C	C	C	-	-
Soluciones de azúcar	A	A	A	A
Soluciones de sal no oxidantes	A	A	A	A
Sosa cáustica	C	A	B	A
Turpentine	A	X	A	A
Tricloretileno 40°C	X	X	A	A
Trióxido de azufre, gas seco	X	B	A	A
Tolueno	C	X	A	A
Whisky, vino	A	A	A	A
Xileno	X	X	A	A

CÓDIGO DE CLASIFICACIÓN

- A Comportamiento excelente
- B Comportamiento bueno
- C Comportamiento regular
- X Incompatible
- Sin datos

COMPUESTO QUÍMICO	FORRO INTERIOR DE LA JUNTA DE EXPANSIÓN			
	NBR	EPDM	FKM	PTFE
	NITRIL	EPDM	VITON	TEFLÓN
Hydraulic oil (petroleum)	A	X	A	A
Linseed oil	A	B	A	A
Olive oil	A	C	A	A
Petroleum oils with high aromatic content	B	X	A	A
Petroleum oils with low aromatic content	A	X	A	A
Resin oil	A	X	A	A
Oil lubrication	A	X	A	A
Transformer oil	X	X	A	A
Oil for mineral based transformers	A	X	A	A
Vegetable oils	A	X	A	A
Acetaldehyde D	X	B	A	A
Acetate	X	A	X	A
Acetate of butilo	X	B	X	A
Ethyl acetate	A	B	X	A
Acetylene	X	A	A	A
Acetone	X	A	X	A
Acetic Acid 5%	B	A	A	A
10%	B	A	A	A
20%	B	A	B	A
30%	B	A	B	A
50%	C	A	C	A
99,5% glacial	C	B	X	A
Anhydrous acetic acid	X	A	X	A
Arsenic acid	B	A	A	A
Hydrobromic acid, max 40°C	C	A	B	A
37% hydrochloric acid	X	A	-	A
37% hydrochloric acid, 70°C	X	X	X	A
Dissolved hydrochloric acid	C	A	A	A
Chlorosulfonic acid	X	X	C	A
Chromic acid	X	C	A	A
Hydrofluorsilicic acid, 40°C	B	A	A	A
50% hydrofluoric acid, 40°C	X	B	A	A
Fluorsilicic Acid	B	B	A	A
Formic acid	X	A	X	A
45% phosphoric acid, 40 °C	C	A	A	A
85%, 40°C	X	B	A	A
Lactic acid	A	A	A	A
Nitric acid 20%, 40°C	X	A	A	A
20%, 50°C	B	A	A	A
40% nitric acid, 50°C	X	B	A	A

COMPUESTO QUÍMICO	FORRO INTERIOR DE LA JUNTA DE EXPANSIÓN			
	NBR	EPDM	FKM	PTFE
	NITRIL	EPDM	VITON	TEFLÓN
50%, 50°C	X	X	A	A
60%, 20°C	X	X	A	A
70%, 20°C	X	X	A	A
Nitric acid smoking	X	X	C	A
Oleic acid	A	X	A	A
Oxalic acid	C	A	B	A
Palmitic acid	A	B	A	A
Salicylic acid	B	A	A	A
<60% sulfuric acid	X	B	A	A
60%, 50°C	X	B	A	A
75%, 50°C	X	B	A	A
80%, 50°C	X	C	A	A
96%, 50°C	X	C	A	A
Sulfuric Acid Smoking	X	X	B	A
Sulfurous acid	C	A	A	A
Distilled water	A	A	A	A
Cold water	A	A	A	A
Cold water, distilled 100 °C	B	A	A	A
Residual water	A	B	A	A
Saltwater	A	A	A	A
Methyl alcohol	B	A	X	-
Liquid ammonium	B	A	X	A
Aniline	C	B	B	A
Argon	C	A	A	A
Melted sulfur	X	B	A	A
Benzene (Benzol)	X	X	A	A
Brandy	A	A	A	A
40°C brea	B	X	A	A
Liquid bromine	X	X	A	A
Butane	A	X	A	A
Butanol (Butyl alcohol)	A	A	A	A
Beer	A	A	A	A
Sulfur chloride	X	X	A	A
Ethyl chloride	B	A	A	A
Methylene chloride	X	X	B	A
Methyl chloride	X	C	A	A
Detergent	A	A	A	A
Sulfur dioxide, dry gas	X	A	A	A
Ethane	A	X	A	A
Ethanol (ethyl alcohol)	A	A	B	A
Ethylene glycol	A	A	A	A
Petroleum ether	B	X	A	A
Ether, ethyl ether	C	X	X	A
Ethylene	X	C	B	A
Ethyl Glycol (Cellosolve)	C	B	C	A

COMPUESTO QUÍMICO	FORRO INTERIOR DE LA JUNTA DE EXPANSIÓN			
	NBR	EPDM	FKM	PTFE
	NITRIL	EPDM	VITON	TEFLÓN
Styrene 40°C	X	X	B	A
Phenol	X	C	A	A
Formaldehyde	B	A	A	A
Fueloil	A	X	A	A
Furan	X	X	C	A
Furfural	X	B	X	A
Hot ammonia gas	X	B	X	A
Cold ammonium gas	A	A	X	A
Hydrochloric gas, humid, 40°C	X	C	C	A
Hydrochloric gas, dry, 40°C	X	C	A	A
LP gas	A	X	A	A
Natural gas	A	X	A	A
Nitrous gas	X	C	X	B
Petrol 100 Oct	C	X	A	A
65 oct	B	X	A	A
Gasoil	A	X	A	A
Glycerin	A	A	A	A
Glucose	A	A	A	A
Animal fats	A	B	A	A
Hydrogen	A	A	A	A
Ammonium hydroxide	C	A	B	A
Calcium hypochlorite	C	A	A	A
Sodium hypochlorite <10 gr/l	C	A	A	A
Sodium hypochlorite > 10 gr/l	X	B	A	A
Milk	A	A	A	A
Black liquor	A	X	A	A
Green liquor, white liquor	A	A	A	A
Liquid manure	A	A	-	A
LP gas, propane	A	X	A	A
MEK Methyl Ethyl Ketone	A	X	X	B
Methyl isobutyl ketone	X	B	X	A
Methyl Isopropyl ketone	X	C	X	A
Nitrobenzene	X	B	B	A
Nitrogen	A	A	A	A
Oxygen	C	A	A	A
Ozone	X	B	A	A
Kerosene paraffin	A	X	A	A
Perchlorethylene	C	X	A	A
Hydrogen peroxide, 3%, 40°C	B	A	A	A
30%, 20°C	C	B	A	A
90%, 20°C	C	-	B	A
Plating sol. W/o chromium	X	A	A	A

COMPUESTO QUÍMICO	FORRO INTERIOR DE LA JUNTA DE EXPANSIÓN			
	NBR	EPDM	FKM	PTFE
	NITRIL	EPDM	VITON	TEFLÓN
Caustic potash	C	B	C	A
Propanol, propyl alcohol	A	A	A	A
Rapeseed oil	X	A	A	A
Ferric salts, non-oxidizing	A	A	A	A
Hydrogen sulphide, wet, 40°C	X	B	X	A
Hydrogen sulphide, wet, 20°C	C	A	X	A
Hydrogen sulfide, dry, 20°C	A	A	X	A
Chlorine solution 0.1 gr./l	A	A	A	A
Chlorine solution 0.1 - 1 gr./l	A	A	A	A
Chlorine solution 1-10 gr./l 40°C	B	B	-	-
Chlorine solution > 10 gr./l 40°C	C	C	-	-
Sugar solutions	A	A	A	A
Non-oxidizing salt solutions	A	A	A	A
Caustic soda	C	A	B	A
Terpentine	A	X	A	A
40°C trichlorethylene	X	X	A	A
Sulfur trioxide, dry gas	X	B	A	A
Toluene	C	X	A	A
Whiskey, wine	A	A	A	A
Xylene	X	X	A	A

SORT CODE

- A Excellent behavior
- B Good behavior
- C Regular behavior
- X Incompatible
- No data

APLICACIONES VÁLVULAS INDUSTRIALES

- VALVULAS INDUSTRIALES
- INSTALACIONES
- CARACTERISTICAS DE LAS INSTALACIONES
- APLICACIONES DE VALVULAS MT A LAS INSTALACIONES

	COMPONENTES						
	REF.	PRESIÓN	TEMPERATURA	CUERPO	EJE	CIERRE	OTROS
FILTRO	5110	16	-20 a 120 - 200	Fundición Epoxi	-	EPDM - PTFE - Grafito	Tamiz inoxidable
	5125	16	0 a 80	Fundición Epoxi	-	NBR	-
VALVULAS RETENCIÓN	5142	16	0 a 80	Fundición Epoxi	-	NBR	-
	5116	16	-20 A 120	Fundición Epoxi	Inoxidable	EPDM	-
	5119	16	- 10 A 150	Inoxidable	Inoxidable	FKM	-
	5118	40	-20 a 300	Inoxidable	Inoxidable	Inoxidable	-
	5143	16	-20 A 120	Fundición Epoxi	Inoxidable	EPDM - NBR	Latón
COMPUERTA	5113	16	-20 a 120	Fundición Epoxi	Inoxidable	EPDM - NBR	Latón
	5132	16	-20 A 180	Inoxidable	Inoxidable	Inoxidable	Inoxidable
	5128	16	-20 A 180	Inoxidable	Inoxidable	PTFE	Bola inoxidable
VALVULA DE BOLA	5117	16	-20 a 180	Acero al carbono	Inoxidable	PTFE	Bola inoxidable
	0910-0917	63	-20 A 180	Inoxidable	Inoxidable	PTFE	Bola inoxidable
	0911-0912	63	-20 a 180	Inoxidable	Inoxidable	PTFE - FKM	Bola inoxidable
VALVULA DE GLOBO	5130	40	-10 a 400	Acero aleado	Inoxidable	Metálico	-
	51302	16	-10 a 400	Acero aleado	Inoxidable	Metálico	-
	5131	16	-20 a 200	Fundición Epoxi	Inoxidable	Metálico	-
	5115	10 - 16	-20 a 120	Fundición Epoxi	Inoxidable	EPDM	DI Cromado
	5114	10 - 16	-20 a 120	Fundición Epoxi	Inoxidable	EPDM	Inoxidable
MARIPOSA	51142	10 - 16	-20 a 80	Fundición Epoxi	Inoxidable	NBR	-
	51143	10 - 16	-20 a 180°C	Fundición Epoxi	Inoxidable	PTFE	-
	5144	10 - 16	-20 a 80	Fundición Epoxi	Inoxidable	NBR	Inoxidable
	5140	10 - 16	-20 a 80	Fundición Epoxi	Inoxidable	EPDM	Rilsan
	5141	10 - 16	-20 a 120	Fundición Epoxi	Inoxidable	EPDM	Inoxidable
	5145	25 - 40	-30 a 200	Fundición Epoxi	Inoxidable	PTFE	Inoxidable
MANGUITOS ELÁSTICOS	5120	16	-20 a 80-120	Acero galvanizado	-	EPDM-NBR	-
	5121	16	-20 a 80-120	Galvanizado	-	EPDM-NBR	-

APPLICATIONS INDUSTRIAL VALVES

- INDUSTRIAL VALVES
- INSTALLATIONS
- CHARACTERISTICS OF THE FACILITIES
- APPLICATIONS OF MT VALVES TO THE FACILITIES

	COMPONENTS						
	REF.	PRESSURE	TEMPERATURE	BODY	STEM	CLOSING	OTHERS
FILTER	5110	16	-20 a 120 - 200	Epoxy Casting	-	EPDM - PTFE - Graphite	Stainless sieve
	5125	16	0 a 80	Epoxy Casting	-	NBR	-
CHECK VALVES	5142	16	0 a 80	Epoxy Casting	-	NBR	-
	5116	16	-20 A 120	Epoxy Casting	Stainless	EPDM	-
	5119	16	- 10 A 150	Stainless	Stainless	FKM	-
	5118	40	-20 a 300	Stainless	Stainless	Stainless	-
	5143	16	-20 A 120	Epoxy Casting	Stainless	EPDM - NBR	Brass
GATE	5113	16	-20 a 120	Epoxy Casting	Stainless	EPDM - NBR	Brass
	5132	16	-20 A 180	Stainless	Stainless	Stainless	Stainless
	5128	16	-20 A 180	Stainless	Stainless	PTFE	Stainless ball
BALL VALVE	5117	16	-20 a 180	Aloy steel	Stainless	PTFE	Stainless ball
	0910-0917	63	-20 A 180	Stainless	Stainless	PTFE	Stainless ball
	0911-0912	63	-20 a 180	Stainless	Stainless	PTFE - FKM	Stainless ball
GLOBE VALVE	5130	40	-10 a 400	Aloy steel	Stainless	Metal	-
	51302	16	-10 a 400	Aloy steel	Stainless	Metal	-
	5131	16	-20 a 200	Epoxy Casting	Stainless	Metal	-
	5115	10 - 16	-20 a 120	Epoxy Casting	Stainless	EPDM	DI Chromed
	5114	10 - 16	-20 a 120	Epoxy Casting	Stainless	EPDM	Stainless
BUTTERFLY	51142	10 - 16	-20 a 80	Epoxy Casting	Stainless	NBR	-
	51143	10 - 16	-20 a 180°C	Epoxy Casting	Stainless	PTFE	-
	5144	10 - 16	-20 a 80	Epoxy Casting	Stainless	NBR	Stainless
	5140	10 - 16	-20 a 80	Epoxy Casting	Stainless	EPDM	Rilsan
	5141	10 - 16	-20 a 120	Epoxy Casting	Stainless	EPDM	Stainless
	5145	25 - 40	-30 a 200	Epoxy Casting	Stainless	PTFE	Stainless
	5120	16	-20 a 80-120	Galvanized steel	-	EPDM-NBR	-
RUBBER EXPANSION JOIN	5121	16	-20 a 80-120	Galvanized	-	EPDM-NBR	-

	TIPO INSTALACIONES	Fluido	Temperatura	Presión
1	Aire comprimido	Aire (78%N - 21%O2 - 1% Otros)	Ambiente	8 - 10 bar
2	Contra incendios (bics o rociadores)	Agua	Ambiente	2 - 6 bar
3	Climatización calefacción	Agua o agua con glicol	4 hasta 90°C	1.5 - 5 bar
4	Energía Solar térmica (Primario)	Agua con glicol	-15 hasta 180°C	1,5 - 3 bar
5	Riego	Agua (con arena, cal etc.)	Ambiente	2 - 6 bar
6	Suministro agua para edificios	Agua mas o menos limpia	4 hasta 70°C	2 - 10 bar
7	Alimentación	Chocolate, mantequilla, mermelada, yogurt etc.	-20 hasta 90°C	1 - 20 bar
8	Vapor	Agua en estado vapor	140 hasta 250	10 - 35bar
9	Depuradoras	Agua sucia (puede contener hidrocarburos)	Ambiente	2 - 20 bar
10	Aguas fecales	Agua sucia (puede contener hidrocarburos)	10 hasta 60°C	1 - 4 bar
11	Químicos en general	Químicos	-	-
12	Sólidos a granel	Pellets, comida para animales	Ambiente	1
13	Vacio	Ausencia de fluido (aire)	Ambiente	<1
14	Centrales de producción energética	Varios	Variada	Variada
15	Piscinas	Agua y concentraciones elevadas de cloro o sales	15 hasta 30	1 - 1,5
16	Gases inertes	Argón, CO2, nitrógeno	-	-
17	Gases comburentes	Oxígeno hidrógeno	-	-
18	Gases combustibles	Gas natural (metano) - GLP (propano - butano)	-	-
19	Instalaciones navales	Agua concentraciones elevadas de sal	Ambiente	2-10bar

ATENCIÓN: Este documento es solo una orientación de las aplicaciones de las válvulas industriales marca MT. Toda aplicación de una válvula deberá ser consultada con un ingeniero conocedor de la instalación que determine, el tipo de válvula mas adecuada, la compatibilidad de sus componentes con los fluidos a controlar y las condiciones de uso y ambientales. En ningún caso es un documento vinculante.

	TYPE FACILITIES	Fluid	Temperature	Pressure
1	Compressed air	Air (78%N - 21%O2 - 1% Otros)	Environment	8 - 10 bar
2	Firefighting (Bics or Sprinklers)	Water	Environment	2 - 6 bar
3	Air conditioning Heating	Water or Water with glycol	4 to 90°C	1.5 - 5 bar
4	Thermal Solar Energy (Primary)	Water with glycol	-15 to 180°C	1,5 - 3 bar
5	Irrigation	Water (with sand, lime etc.)	Environment	2 - 6 bar
6	Water supply for buildings	More or less clean water	4 to 70°C	2 - 10 bar
7	Feeding	Chocolate, butter, jam, yogurt etc.	-20 a 90°C	1 - 20 bar
8	Steam	Steam water	140 to 250	10 - 35bar
9	Sewage treatment plants	Dirty water (may contain hydrocarbons)	Environment	2 - 20 bar
10	Sewage	Dirty water (may contain hydrocarbons)	10 to 60°C	1 - 4 bar
11	General chemicals	Chemicals	-	-
12	Bulk solids	Pellets, animal food	Environment	1
13	Empty	Absence of fluid (air)	Environment	<1
14	Power plants	Various	Varied	Varied
15	Swimming pools	Water and high concentrations of chlorine or salts	15 to 30	1 - 1,5
16	Inert gases	Argon, CO2, nitrogen	-	-
17	Oxidizing gases	Hydrogen oxygen	-	-
18	Combustible gases	Natural gas (methane) - LPG (propane - butane)	-	-
19	Naval Facilities	Water high salt concentrations	Environment	2-10bar

ATTENTION: This document is only an orientation of the applications of the MT brand industrial valves. Any application of a valve must be consulted with an engineer who knows the installation that determines the most appropriate type of valve, the compatibility of its components with the fluids to be controlled and the conditions of use and environmental conditions. In no case is it a binding document.

TIPO INSTALACIONES FACILITIES TYPE		1	2	3	4	5	6	7	8	9	10	11	12	13	14	15	16	17	18	19
FILTRO FILTER	5110	√	√	√	√(*1)	√	√(*2)	X	√(*3)	√	√	-	X	X	√(*4)	X	X	X	X	X
	5125	X	√	X	X	√	√	X	X	√	√	X	√(*5)	X	√(*4)	X	X	X	X	X
VALVULAS RETENCIÓN CHECK VALVE	5142	X	√	X	X	√	√	X	X	√	√	X	√(*5)	X	√(*4)	X	X	X	X	X
	5116	√	√	√	X	X	√	X	X	X	X	X	X	X	√(*4)	X	X	X	X	X
	5119	√	√	√	√	X	√	√	X	X	X	-	√	X	√(*4)	X	X	X	X	X
	5118	√	√	√	√	X	√	√	X	X	X	-	X	X	√(*4)	X	√(*9)	√(*9)	X	√
COMPUERTA GATE	5143	X	√	X	X	√	√	X	X	√	√(*8)	-	X	X	√(*4)	X	X	X	X	X
	5113	X	√	X	X	√	√	X	X	√	√(*8)	-	X	X	√(*4)	X	X	X	X	X
	5132	X	√	√	√	X	√	√	X	√	√	-	√	X	√(*4)	X	√(*9)	√(*9)	X	√
VALVULA DE BOLA BALL VALVE	5128	√	√	√	√	X	√	√	X	√	√	-	X	X	√(*4)	X	√(*9)	√(*9)	X	√
	5117	√	√	√	√	X	X	X	X	√	√	-	X	X	√(*4)	X	X	X	X	X
	0910-0917	√	√	√	√	√	√	-	X	√	√	√	X	X	√	X	√(*9)	√(*9)	X	√
	0911-0912	√	√	√	√	√	√	-	√	√	√	SO	X	X	√	X	√(*9)	√(*9)	X	√
VALVULA DE GLOBO GLOBE VALVE	5130	X	X	X	X	X	X	X	√	X	X	-	X	X	√(*4)	X	X	X	X	X
	51302	X	X	X	X	X	X	X	√	X	X	-	X	X	√(*4)	X	X	X	X	X
	5131	X	X	X	X	X	X	X	√	X	X	-	X	X	√(*4)	X	X	X	X	X
	5115	X	√	X	X	√	X	X	X	X	X	-	X	X	√(*4)	X	X	X	X	X
	5114	X	√	√	X	√	√	X	X	√(*7)	√(*7)	-	√	X	√(*4)	X	X	X	X	X
MARIPOSA BUTTERFLY	51142	X	√	√	X	√	√	X	X	√	√	-	√	X	√(*4)	X	X	X	X	X
	51143	X	X	X	X	X	X	X	X	√	√	-	X	X	√(*4)	√	X	X	X	X
	5144	X	√	√	X	√	√	X	X	√	√	-	√	X	√(*4)	X	X	X	X	X
	5140	X	X	X	X	X	X	X	X	√	√	-	X	X	√(*4)	√	X	X	X	X
	5141	X	√	√	X	√	√	X	X	√	√	-	√	X	√(*4)	X	X	X	X	X
	5145	X	X	√	√	X	X	X	X	X	X	-	X	X	√(*4)	X	X	X	X	X
MANGUITOS ELÁSTICOS RUBBER EXPANSION JOIN	5120	√(*6)	√	√	X	√	√	X	X	√(*7)	√(*7)	-	√	X	√(*4)	X	X	X	X	X
	5121	√(*6)	√	√	X	√	√	X	X	√(*7)	√(*7)	-	√	X	√(*4)	X	X	X	X	X

POSIBLES PROBLEMAS POR ENTORNO

Corrientes inducidas.

Condiciones ambientales.

Desengrase de las válvulas.

Se pueden desengrasar bajo precio.

- Se debe cambiar la junta por una de Grafito.
- Depende de la exigencia de filtrado no cumple.
- Se debe cambiar la junta por una de Grafito y no superar los 200°C.
- Depende de la aplicación concreta. Libres de silicona. Se pueden desengrasar bajo precio.
- Si con reservas del tipo de sólido.
- Sólo la versión de NBR.
- Versión NBR por si contienen aceites o hidrocarburos.
- En caso de aceites e hidrocarburos su aplicación no es aconsejable.
- Se deben de limpiar y desengrasar específicamente. Cuidado con la junta.

POSSIBLE PROBLEMS BY ENVIRONMENT

Induced currents.

Environmental conditions.

Degreasing the valves.

You can degrease low price.

- The board must be replaced with a Graphite one.
- Depends on filtering requirement does not meet.
- The joint must be replaced with a Graphite one and not exceed 200°C.
- Depends on the specific application. Silicone-free. Can be degreased at a low price.
- If with solid type reservations.
- Only the NBR version.
- NBR version if they contain oils or hydrocarbons.
- In the case of oils and hydrocarbons, it's application is not advisable.
- Must be cleaned and degreased specifically, Take care with the seal.

COEFICIENTE DE CAUDAL KV

Kv es el coeficiente de caudal en unidades métricas. Se define como el caudal en metros cúbicos por hora [m³/h] de agua a una temperatura de 16° celsius con una caída de presión a través de la válvula de 1 bar.

Cv es el coeficiente de caudal en unidades imperiales. Se define como el caudal en galones US por minuto [gpm] de agua a la temperatura de 60° fahrenheit con una caída de presión a través de la válvula de 1 psi.

Cuando el flujo pasa a través de una válvula o otro dispositivo restrictivo pierde una energía. El **coeficiente de caudal** es un factor de diseño que relaciona la diferencia de altura (Δh) o presión (ΔP) entre la entrada y salida de la válvula con el caudal (Q). Este coeficiente permite calcular la pérdida de presión (ΔP) en la válvula para el caudal de trabajo.

Cada válvula tiene su propio coeficiente de caudal. Éste depende de como la válvula ha sido diseñada para dejar pasar el flujo a través de ella. Por consiguiente, las mayores diferencias entre diferentes coeficientes de caudal provienen del tipo de válvula, y naturalmente de la posición de obturación de la válvula.

Puede ser importante conocer el coeficiente de caudal para poder seleccionar la válvula que se necesita en una específica aplicación. Si la válvula va a estar la mayor parte del tiempo abierta, posiblemente interesará elegir una válvula con poca pérdida de carga para poder ahorrar energía. O si se trata de una válvula de control, el rango de coeficientes de caudal en las diferentes posiciones de obturación tendrían de permitir cumplir las necesidades de regulación de la aplicación.

ESQUEMA

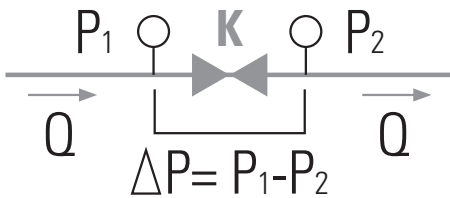

FÓRMULAS

Las fórmulas aquí referenciadas se pueden usar solo para líquidos con densidades y viscosidades cercanas a las del agua.

Equivalencia entre Kv y Cv:

$$Kv = 0.865 \cdot Cv$$

$$Cv = 1,156 \cdot Kv$$

Calculo de la pérdida de presión con caudal conocido:

$$\Delta P = \left[\frac{Q}{K} \right]^2 \cdot SG$$

Calculo del caudal con la pérdida de presión conocida:

$$Q = K \cdot \sqrt{\frac{\Delta P}{SG}}$$

Q: Caudal

ΔP : Diferencia de presión, pérdida de carga

SG: Gravedad específica (1 para agua)

K: Coeficiente de caudal Kv o Cv

SG: La gravedad específica es un numero adimensional, es decir no posee unidades. Es la relación entre la densidad de una sustancia y la densidad de otra tomada como referencia denominada sustancia patrón. Por convención, la sustancia patrón para sustancias liquidas y solidas es el agua (1), y para gases o vapores es el aire, cuya densidad en condiciones normales es 1,29 g / L..

KV FLOW COEFFICIENT

Kv is the flow coefficient in metric units. It is defined as the flow rate in cubic meters per hour [m³ / h] of water at a temperature of 16 ° Celsius with 1 bar pressure drop through the valve.

Cv is the flow coefficient in Imperial units. It is defined as the flow rate in US gallons per minute [gpm] of water at a temperature of 60 ° Fahrenheit with 1 PSI pressure drop through the valve.

When the flow passes through a valve or other restrictive device, it loses energy. The **flow coefficient** is a design factor that relates the difference in height (Δh) or pressure (ΔP) between the valve inlet and outlet with the flow rate (Q). This coefficient allows to calculate the pressure loss (ΔP) in the valve for the working flow.

Each valve has its own flow rate. It depends on how the valve has been determined to let the flow through it. In general, the greatest differences between different flow coefficients come from the type of valve, and of course from the valve opening position.

It is important to know the flow rate to be able to select the valve needed in each specific application. If the valve is going to be in open position most of the time, it may be interesting to choose a valve with little pressure loss to save energy. If it is a control valve, the range of flow coefficients in the different overture positions should allow the application regulation needs to be met.

SCHEME

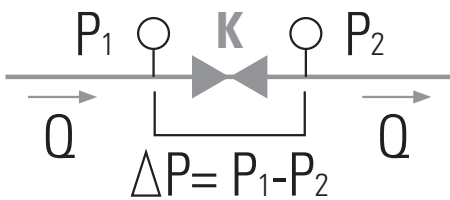

FORMULAS

The formulas here mentioned should be used only for liquids with densities and viscosities specific to those of water.

Equivalence between Kv and Cv:

$$Kv = 0.865Cv$$

$$Cv = 1,156 Kv$$

Calculation of pressure loss with known flow:

$$\Delta P = \left[\frac{Q}{K} \right]^2 \cdot SG$$

Flow calculation with known pressure loss:

$$Q = K \cdot \sqrt{\frac{\Delta P}{SG}}$$

Q: Flow

ΔP : Pressure difference, pressure drop

SG: Specific Gravity (1 for water)

K: Flow coefficient Kv or Cv

SG: The specific gravity is a dimensionless number, that is, it has no units. It is the relationship between the density of one substance and the density of another taken as a patron. By convention, the standard substance for liquid and solid substances is water (1), and gases or steam is air, whose density under normal conditions is 1.29 g / L.



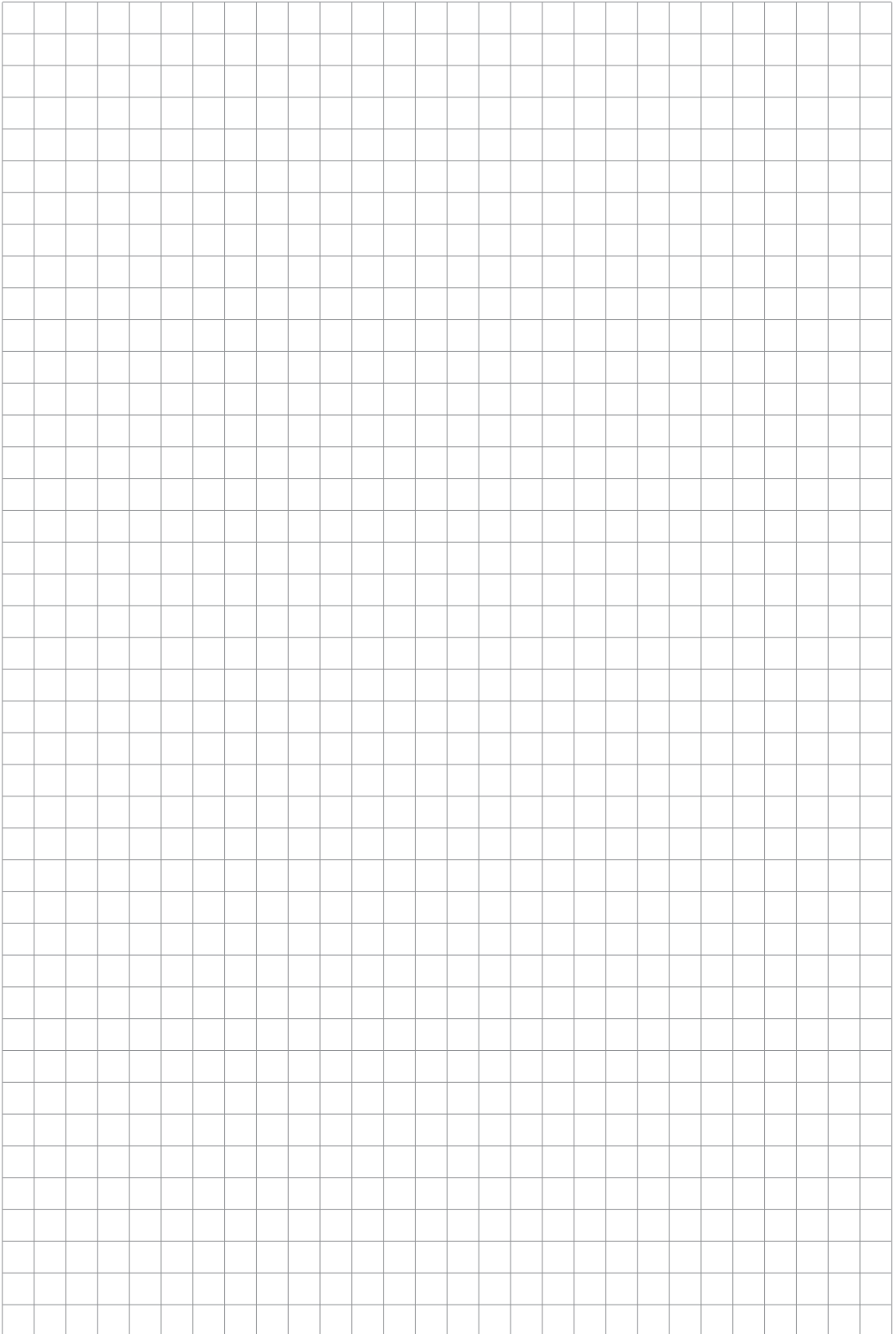



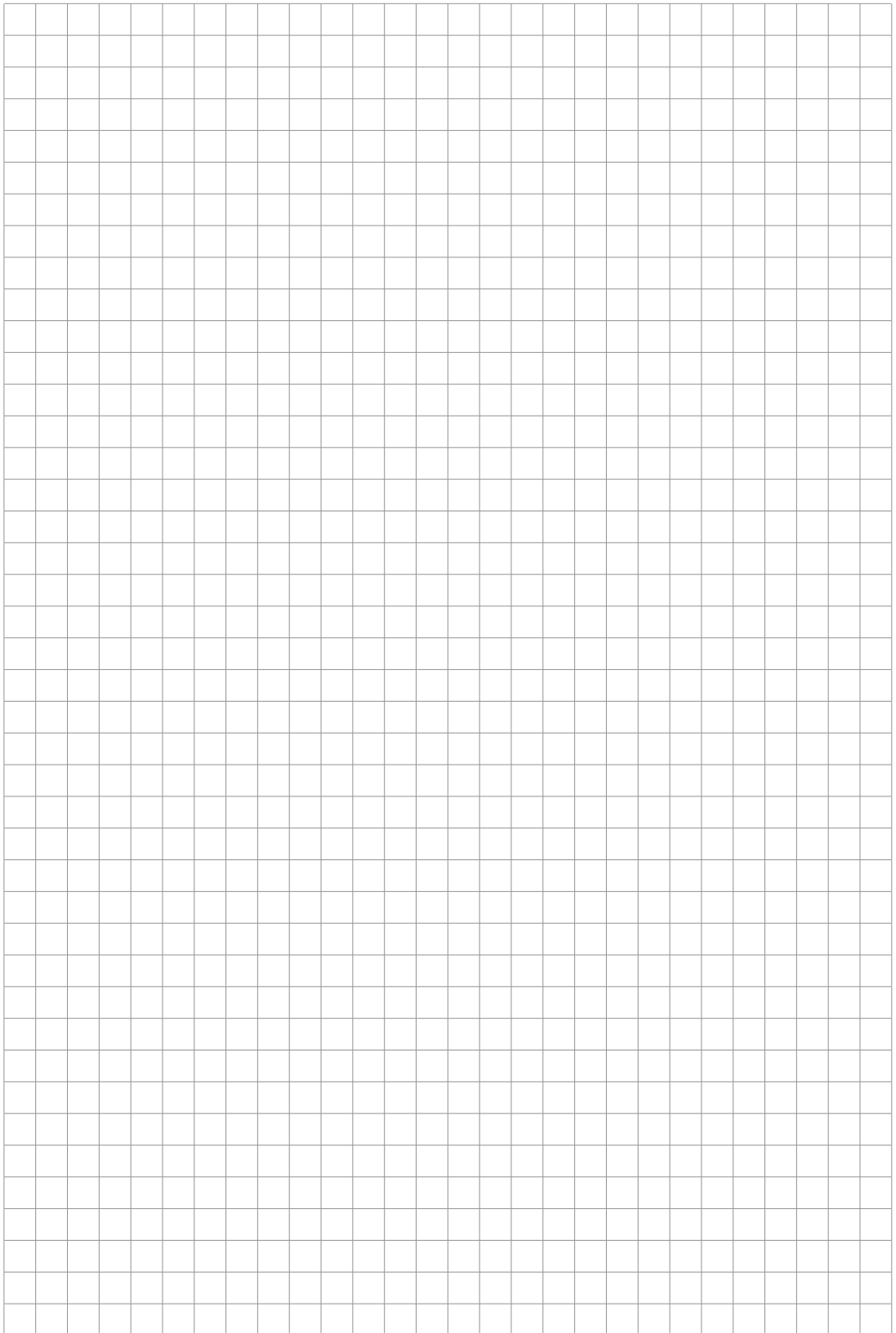



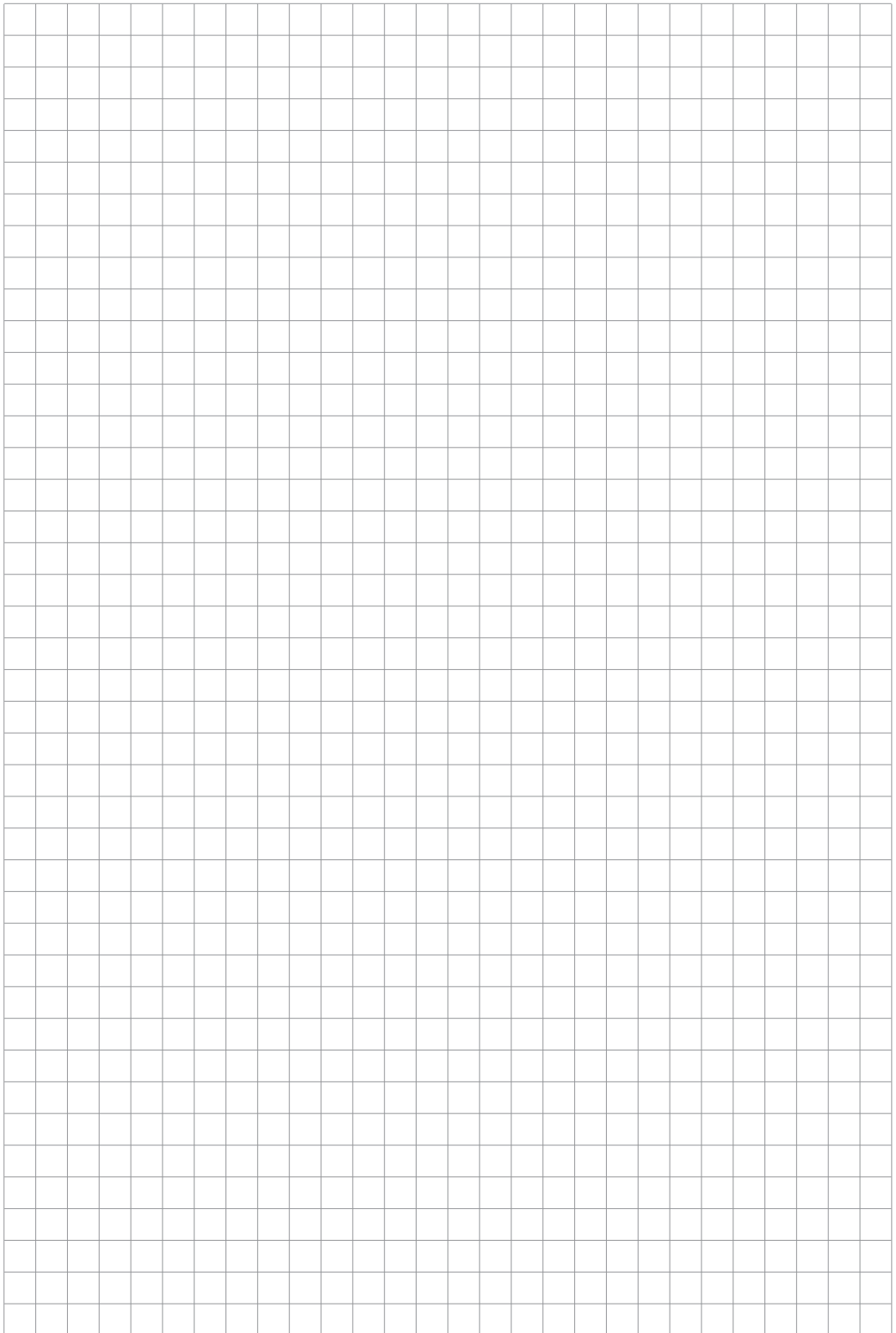

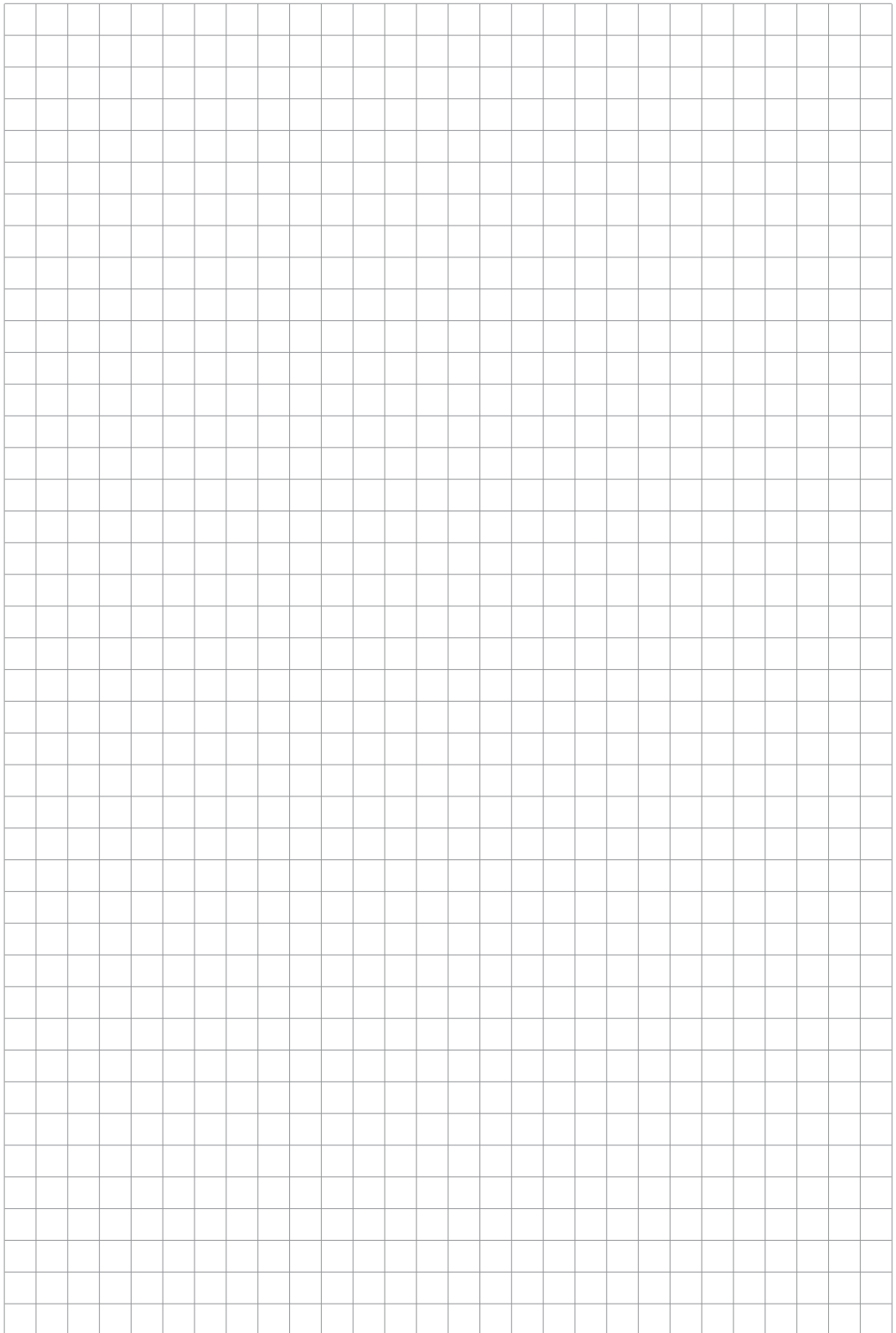



VALVES AND FITTINGS

mtspain.net

tel. +34 **936 804 980**
info@mtspain.net

V4